

Σ -II SERIES SGDh
DeviceNet INTERFACE UNIT
USER'S MANUAL

MODEL: JUSP-NS310

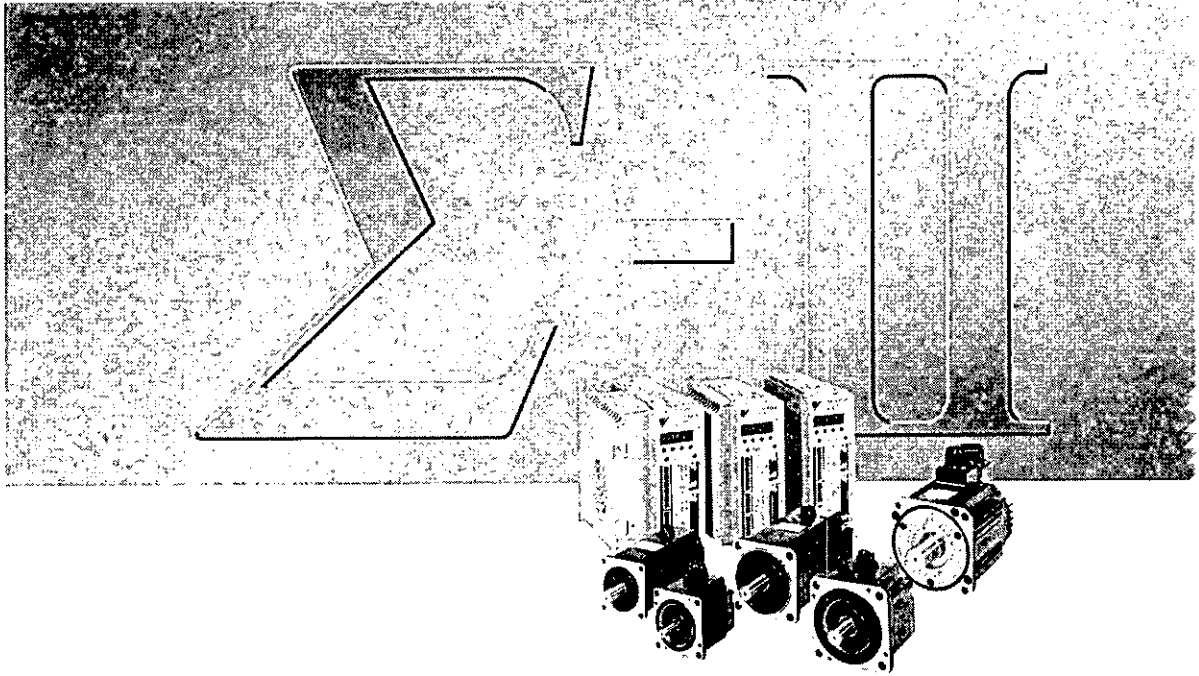

YASKAWA

MANUAL NO. SIE-C718-7



Safety Information

The following conventions are used to indicate precautions in this manual. Failure to heed precautions provided in this manual can result in serious or possibly even fatal injury or damage to the products or to related equipment and systems.

 **WARNING** Indicates precautions that, if not heeded, could possibly result in loss of life or serious injury.

 **Caution** Indicates precautions that, if not heeded, could result in relatively serious or minor injury, damage to the product, or faulty operation.

©Yaskawa, 2000

All rights reserved. No part of this publication may be reproduced, stored in a retrieval system, or transmitted, in any form, or by any means, mechanical, electronic, photocopying, recording, or otherwise, without the prior written permission of Yaskawa. No patent liability is assumed with respect to the use of the information contained herein. Moreover, because Yaskawa is constantly striving to improve its high-quality products, the information contained in this manual is subject to change without notice. Every precaution has been taken in the preparation of this manual. Nevertheless, Yaskawa assumes no responsibility for errors or omissions. Neither is any liability assumed for damages resulting from the use of the information contained in this publication.

Visual Aids

The following aids are used to indicate certain types of information for easier reference.



Indicates application examples.



Indicates supplemental information.



Indicates important information that should be memorized.



◆ Explains difficult to understand terms and terms that have not been explained before.

OVERVIEW

Visual Aids	iv
Overview	xi
Using This Manual	xii
<hr/>	
TABLE OF CONTENTS	vii
Safety Precautions	xiii
1 Checking Products and Part Names	1 - 1
1.1 Checking Products on Delivery	1 - 2
1.2 Product Part Names	1 - 4
1.3 Mounting the NS310 Unit	1 - 5
2 Installation	2 - 1
2.1 Storage Conditions	2 - 2
2.2 Installation Site	2 - 2
2.3 Orientation	2 - 3
2.4 Installation	2 - 4
3 Connectors	3 - 1
3.1 Connecting to Peripheral Devices	3 - 2
3.2 SERVOPACK Internal Block Diagrams	3 - 5
3.3 I/O Signals	3 - 6
3.4 Connections for DeviceNet Communications	3 - 11
4 Parameter Settings	4 - 1
4.1 Parameter Outline	4 - 2
4.2 Parameters Tables	4 - 5
4.3 Parameter Details	4 - 11
5 DeviceNet Communications	5 - 1
5.1 Specifications and Configuration	5 - 3
5.2 DeviceNet Communications Setting Switches	5 - 4
5.3 Command/Response Format	5 - 7
5.4 Commands from the Host Controller	5 - 15
5.5 Program Function	5 - 24
5.6 Changing Parameters and Command Blocks	5 - 34
6 SGDH Parameters	6 - 1
6.1 Parameters and Standard Settings for NS310 Units	6 - 2
6.2 Settings According to Equipment Characteristics	6 - 4
6.3 Settings According to Host Controller	6 - 6
6.4 Setting Up the SERVOPACK	6 - 8
6.5 Setting Stop Functions	6 - 12
6.6 Absolute Encoders	6 - 17
6.7 Digital Operator	6 - 21

7	Using the NSxxx Setup Tool	7 - 1
7.1	Connection and Installation	7 - 2
7.2	How to Use	7 - 3
8	Ratings, Specifications, and Dimensions	8 - 1
8.1	Ratings and Specifications	8 - 2
8.2	Dimensional Drawings	8 - 3
9	Troubleshooting	9 - 1
9.1	Troubleshooting Problems with Alarm Displays	9 - 2
9.2	Troubleshooting Problems with No Alarm Display	9 - 19
9.3	Alarm Display Table	9 - 21
9.4	Warning Displays	9 - 24
<hr/>		
A	DeviceNet Object Model	A - 1
B	DeviceNet Attributes	B - 1
C	Alarm and Warning Codes	C - 1

TABLE OF CONTENTS

Visual Aids	iv
Overview	xi
Using This Manual	xii
1 Checking Products and Part Names	1 - 1
1.1 Checking Products on Delivery	1 - 2
1.2 Product Part Names	1 - 4
1.3 Mounting the NS310 Unit	1 - 5
2 Installation	2 - 1
2.1 Storage Conditions	2 - 2
2.2 Installation Site	2 - 2
2.3 Orientation	2 - 3
2.4 Installation	2 - 4
3 Connectors	3 - 1
3.1 Connecting to Peripheral Devices	3 - 2
3.1.1 Single-phase (100 V or 200 V) Main Circuit Specifications	3 - 3
3.1.2 Three-phase 200 V Main Circuit Specifications	3 - 4
3.2 SERVOPACK Internal Block Diagrams	3 - 5
3.3 I/O Signals	3 - 6
3.3.1 Connection Example of I/O Signal Connector (CN1)	3 - 6
3.3.2 I/O Signals Connector (CN1)	3 - 7
3.3.3 I/O Signal Names and Functions	3 - 8
3.3.4 Interface Circuits	3 - 9
3.4 Connections for DeviceNet Communications	3 - 11
3.4.1 DeviceNet Communications Connection Example	3 - 11
3.4.2 DeviceNet Communications Connectors (CN6)	3 - 13
3.4.3 Precautions for Wiring DeviceNet Cables	3 - 15
3.4.4 Grounding	3 - 18
4 Parameter Settings	4 - 1
4.1 Parameter Outline	4 - 2
4.1.1 What Are Parameters?	4 - 2
4.1.2 Parameter Types	4 - 2
4.1.3 Editing Parameters	4 - 3
4.1.4 Effective Timing	4 - 4

4.2 Parameters Tables	4 - 5
4.2.1 Unit Parameters	4 - 5
4.2.2 Homing Parameters	4 - 5
4.2.3 Machine System and Peripheral Device Parameters	4 - 7
4.2.4 Speed, Acceleration, and Deceleration Parameters	4 - 8
4.2.5 Positioning Parameters	4 - 10
4.3 Parameter Details	4 - 11
4.3.1 Unit Parameters	4 - 11
4.3.2 Homing Parameters	4 - 14
4.3.3 Machine System and Peripheral Device Parameters	4 - 18
4.3.4 Speed, Acceleration, and Deceleration Parameters	4 - 24
4.3.5 Positioning Parameters	4 - 35
5 DeviceNet Communications	5 - 1
5.1 Specifications and Configuration	5 - 3
5.1.1 Specifications	5 - 3
5.1.2 Control Configuration	5 - 3
5.2 DeviceNet Communications Setting Switches	5 - 4
5.2.1 Rotary Switch Settings for Setting Node Address	5 - 4
5.2.2 Rotary Switch Settings for Setting Baud Rate	5 - 5
5.2.3 LED Indicators	5 - 5
5.3 Command/Response Format	5 - 7
5.3.1 Command Format	5 - 7
5.3.2 Command Data Specifications	5 - 9
5.3.3 Response Format	5 - 11
5.4 Commands from the Host Controller	5 - 15
5.4.1 Positioning	5 - 15
5.4.2 Continuous Rotary Operation	5 - 16
5.4.3 Homing	5 - 18
5.4.4 Hard Stop Operation	5 - 20
5.4.5 Deceleration and Stop Operation	5 - 21
5.4.6 Emergency Stop Operation	5 - 21
5.4.7 Hardware Limit Operation	5 - 22
5.4.8 Software Limit Operation	5 - 23
5.5 Program Function	5 - 24
5.5.1 Outline	5 - 24
5.5.2 Command Blocks	5 - 26
5.5.3 Command Block Links	5 - 32
5.6 Changing Parameters and Command Blocks	5 - 34
5.6.1 DeviceNet Data Management	5 - 34
5.6.2 Editing Parameters	5 - 35
5.6.3 Editing Command Blocks	5 - 37
5.6.4 Organizing Data	5 - 37

6	SGDH Parameters	6 - 1
6.1	Parameters and Standard Settings for NS310 Units	6 - 2
6.1.1	Parameters	6 - 2
6.1.2	Standard Settings for CN1 I/O Signals	6 - 3
6.2	Settings According to Equipment Characteristics	6 - 4
6.2.1	Switching Servomotor Rotation Direction	6 - 4
6.2.2	Stop Mode Selection at Servo OFF	6 - 4
6.3	Settings According to Host Controller	6 - 6
6.4	Setting Up the SERVOPACK	6 - 8
6.4.1	Parameters	6 - 8
6.4.2	Input Circuit Signal Allocation	6 - 8
6.4.3	Output Circuit Signal Allocation	6 - 9
6.5	Setting Stop Functions	6 - 12
6.5.1	Using the Dynamic Brake	6 - 12
6.5.2	Using the Holding Brake	6 - 13
6.6	Absolute Encoders	6 - 17
6.6.1	Selecting an Absolute Encoder	6 - 17
6.6.2	Absolute Encoder Setup	6 - 18
6.6.3	Multiturn Limit Setting	6 - 18
6.7	Digital Operator	6 - 21
6.7.1	Connecting the Digital Operator	6 - 21
6.7.2	Limitations in Using a Hand-held Digital Operator	6 - 21
6.7.3	Panel Operator Indicators	6 - 21
7	Using the NSxxx Setup Tool	7 - 1
7.1	Connection and Installation	7 - 2
7.1.1	Connecting the NS310 Unit	7 - 2
7.1.2	Software Installation	7 - 2
7.2	How to Use	7 - 3
7.2.1	Screen Configuration at Startup	7 - 3
7.2.2	Functions Configuration	7 - 5
8	Ratings, Specifications, and Dimensions	8 - 1
8.1	Ratings and Specifications	8 - 2
8.2	Dimensional Drawings	8 - 3
8.2.1	NS310 Unit	8 - 3
9	Troubleshooting	9 - 1
9.1	Troubleshooting Problems with Alarm Displays	9 - 2
9.2	Troubleshooting Problems with No Alarm Display	9 - 19
9.3	Alarm Display Table	9 - 21
9.4	Warning Displays	9 - 24

A	DeviceNet Object Model	A - 1
B	DeviceNet Attributes	B - 1
B.1	Identity Object (0x01)	B - 2
B.2	Message Router Object (0x02)	B - 3
B.3	DeviceNet Object (0x03)	B - 4
B.4	Assembly Object (0x04)	B - 5
B.5	Connection Object (0x05)	B - 6
B.6	Position Controller Supervisor Object (0x24)	B - 8
B.7	Position Controller Object (0x25)	B - 9
B.8	Block Sequencer Object (0x26)	B - 12
B.9	Command Block Object (0x27)	B - 13
B.10	Control Parameter Object (0x64)	B - 14
B.11	SERVOPACK Parameter Object (0x66)	B - 18
C	Alarm and Warning Codes	C - 1
C.1	Alarm Codes	C - 2

Overview

■ About this Manual

This manual provides the following information for the Σ -II Series SGM□H/SGDH Servodrives with a JUSP-NS310 DeviceNet Interface Unit (hereinafter called NS310 Unit) mounted. The NS310 Unit is an Option Unit.

- Procedures for installing and wiring the NS310 Unit
- Specifications and methods for SERVOPACK DeviceNet communications
- Procedures for setting parameters
- Information on the NSxxx Setup Tool
- Troubleshooting procedures

■ Related Manuals

Refer to the following manuals as required.

Read this manual carefully to ensure the proper use of Σ -II Series Servodrives. Also, keep this manual in a safe place so that it can be referred to whenever necessary.

Manual Name	Manual Number	Contents
Σ -II Series SGM□H/SGDH User's Manual Servo Selection and Data Sheets	SIE-S800-32.1	Describes the procedure used to select Σ -II Series Servodrives and capacities.
Σ -II Series SGM□H/SGDH User's Manual Design and Maintenance	SIE-S800-32.2	Provides detailed information on SGDH SERVOPACKs.
MP920 Machine Controller User's Manual Design and Maintenance	SIE-S887-2.1	Explains in detail the functions, specifications, and application methods of the MP920 as a host controller.

Using This Manual

■ Intended Audience

This manual is intended for the following users.

- Those designing Servodrive systems using DeviceNet.
- Those designing Σ -II Series Servodrive systems.
- Those installing or wiring Σ -II Series Servodrives.
- Those performing trial operation or adjustments of Σ -II Series Servodrives.
- Those maintaining or inspecting Σ -II Series Servodrives.

■ Description of Technical Terms

In this manual, the following terms are defined as follows:

- **NS310 Unit** = JUSP-NS310
- **Servomotor** = Σ -II Series SGMAH, SGMPH, SGMGH, or SGMSH servomotor.
- **SERVOPACK** = Σ -II Series SGDH-□□□E SERVOPACK.
- **Servodrive** = A set including a servomotor and Servo Amplifier.
- **Servo System** = A servo control system that includes the combination of a Servodrive with a host computer and peripheral devices.

■ Indication of Reverse Signals

In this manual, the names of reverse signals (ones that are valid when low) are written with a forward slash (/) before the signal name, as shown in the following examples:

- /S-ON
- /P-CON

■ Registered Trademark

DeviceNet is a registered trademark of ODVA (Open DeviceNet Vender Association, Inc.).

Safety Precautions

The following precautions are for checking products upon delivery, installation, wiring, operation, maintenance and inspections.

■ Checking Products upon Delivery

CAUTION

- Always use the servomotor and SERVOPACK in one of the specified combinations.
Not doing so may cause fire or malfunction.

■ Installation

CAUTION

- Never use the products in an environment subject to water, corrosive gases, inflammable gases, or combustibles.
Doing so may result in electric shock or fire.

■ Wiring

WARNING

- Connect the SERVOPACK ground terminal effectively to a system grounding conductor or grounding electrode (100 Ω or less).
Improper grounding may result in electric shock or fire.

CAUTION

- Do not connect a three-phase power supply to SERVOPACK U, V, or W output terminals.
Doing so may result in injury or fire.
- Securely fasten the power supply terminal screws and motor output terminal screws.
Not doing so may result in fire.

■ Operation

WARNING

- Never touch any rotating motor parts while the motor is running.
Doing so may result in injury.

CAUTION

- Conduct trial operation on the servomotor alone with the motor shaft disconnected from machine to avoid any unexpected accidents.
Not doing so may result in injury.
- Before starting operation with a machine connected, change the settings to match the parameters of the machine.
Starting operation without matching the proper settings may cause the machine to run out of control or malfunction.
- Before starting operation with a machine connected, make sure that an emergency stop can be applied at any time.
Not doing so may result in injury.
- Do not touch the heat sinks during operation.
Doing so may result in burns due to high temperatures.

■ Maintenance and Inspection

WARNING

- Never touch the inside of the SERVOPACKs.
Doing so may result in electric shock.
- Do not remove the panel cover while the power is ON.
Doing so may result in electric shock.
- Do not touch terminals for five minutes after the power is turned OFF.
Residual voltage may cause electric shock.

CAUTION

- Do not disassemble the servomotor.
Doing so may result in electric shock or injury.
- Do not attempt to change wiring while the power is ON.
Doing so may result in electric shock or injury.

■ General Precautions**Note the following to ensure safe application.**

- The drawings presented in this manual are sometimes shown without covers or protective guards. Always replace the cover or protective guard as specified first, and then operate the products in accordance with the manual.
- The drawings presented in this manual are typical examples and may not match the product you received.
- This manual is subject to change due to product improvement, specification modification, and manual improvement. When this manual is revised, the manual code is updated and the new manual is published as a next edition. The edition number appears on the front and back covers.
- If the manual must be ordered due to loss or damage, inform your nearest Yaskawa representative or one of the offices listed on the back of this manual.
- Yaskawa will not take responsibility for the results of unauthorized modifications of this product. Yaskawa shall not be liable for any damages or troubles resulting from unauthorized modification.

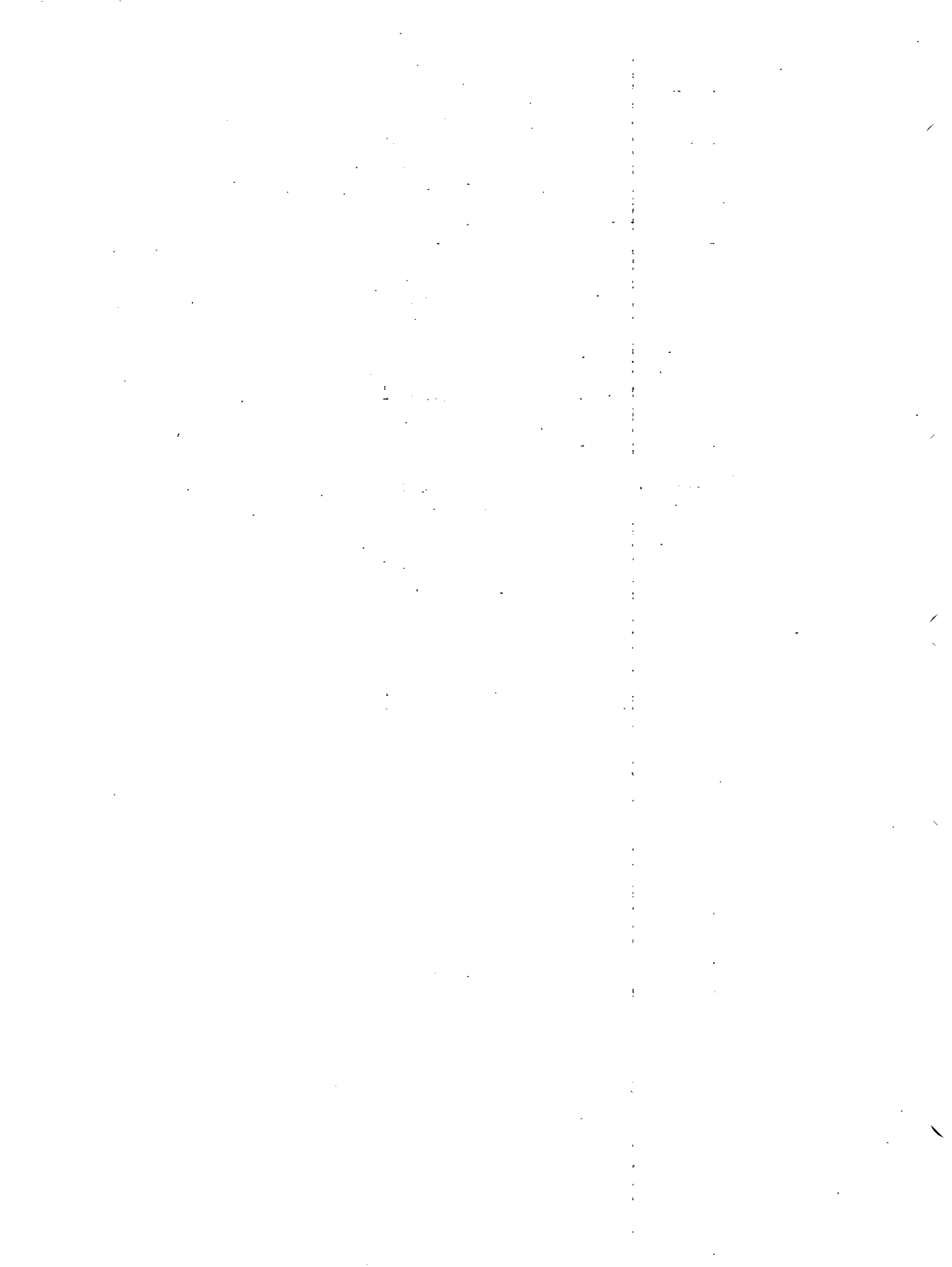

1

Checking Products and Part Names

This chapter describes the procedure for checking Σ -II Series products and the NS310 Unit upon delivery. It also describes the names of product parts.

1.1 Checking Products on Delivery	1 - 2
1.2 Product Part Names	1 - 4
1.3 Mounting the NS310 Unit	1 - 5

1.1 Checking Products on Delivery

The following procedure is used to check products upon delivery. Check the following items when products are delivered.

Check Items	Comments
Are the delivered products the ones that were ordered?	Check the model numbers marked on the nameplates of the NS310 Unit. (Refer to the descriptions of model numbers on following pages)
Is there any damage?	Check the overall appearance, and check for damage or scratches that may have occurred during shipping.
Can the NS310 Unit be installed on the SERVOPACK used?	Check the model number given on the SERVOPACK nameplate. The model number must contain "SGDH" and "E" as shown below to support the NS310 Unit. SGDH-□□□E-□

If any of the above items are faulty or incorrect, contact your Yaskawa sales representative or the dealer from whom you purchased the products.

External Appearance and Nameplate Example

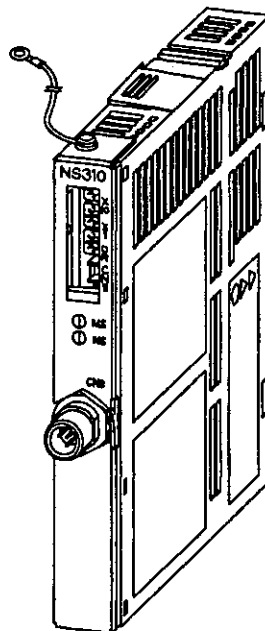

Figure 1.1 External Appearance of the NS310 Unit

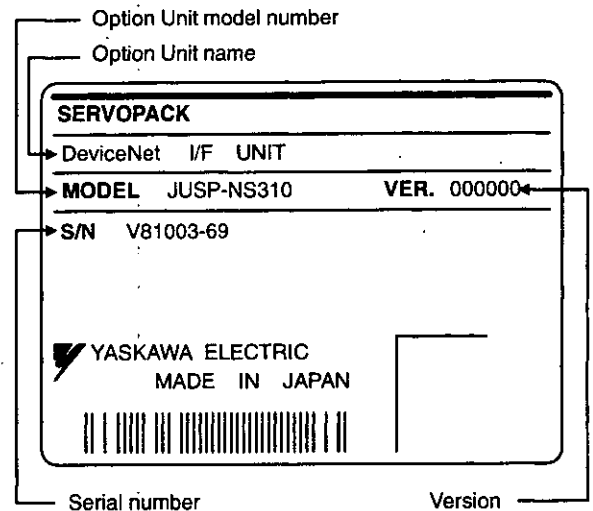

Figure 1.2 Nameplate

■ **Model Number**

NS310 Unit

JUSP – NS31 0

SERVOPACK peripheral device

Type of device:
NS31: DeviceNet Interface Unit

Design Revision Order



1.2 Product Part Names

The following diagram illustrates the part names of the NS310 Unit.

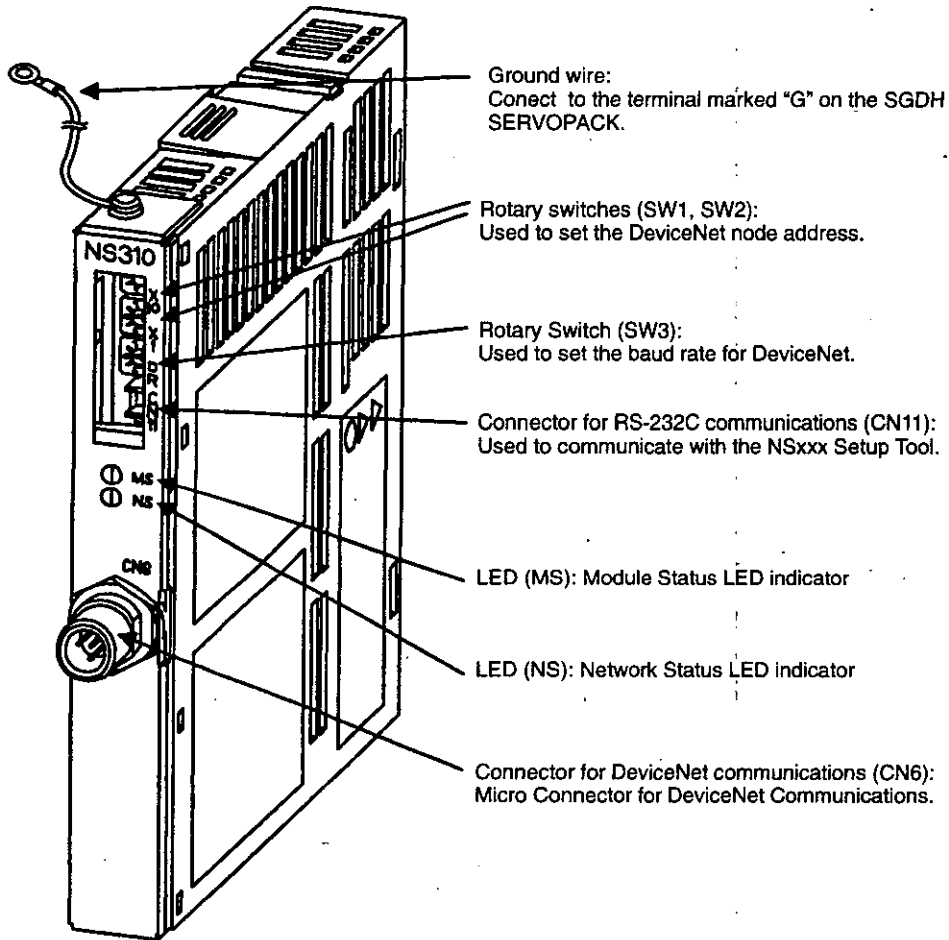

Figure 1.3 NS310 Unit

1.3 Mounting the NS310 Unit

This section describes how to mount an NS310 Unit on the SGD H SERVOPACK.

Prepare the screws for connecting the ground wire as shown in the following table:

Mounting Type	SERVOPACK Models	Screws	Remarks
Base Mounted	SGDH-A3 to 02BE SGDH-A3 to 10AE	M3 x 10 round-head screws (Spring or flat washer)	Prepared by customer
	SGDH-15 to 50AE SGDH-05 to 30DE	M4 x 10 round-head screws (Spring or flat washer)	Prepared by customer
	SGDH-60/75AE	M4 x 8 round-head screws (Spring or flat washer)	Use front panel fixer screws
Rack Mounted	SGDH-A3 to 02BE-R SGDH-A3 to 50AE-R SGDH-05 to 30DE-R	M4 x 6 round-head screws (Spring or flat washer)	Prepared by customer (see note)
Duct Vent	SGDH-60/75AE-P	M4 x 8 round-head screws (Spring or flat washer)	Use front panel fixer screws

Note: Be sure to use spring washers or flat washers. Failure to do so may result in the screws for connecting the ground wire protruding behind the flange, preventing the SERVOPACK from being mounted.

By mounting an NS310 Unit, the SGD H SERVOPACK can be used in a DeviceNet network. Use the following procedure to ensure NS310 Units are mounted correctly.

1. Remove the connector cover from the CN10 connector on the SERVOPACK.

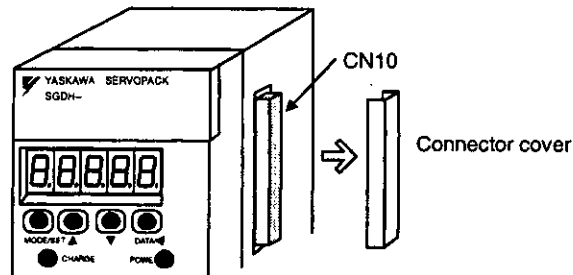

2. Mount the NS310 Unit on the SERVOPACK.

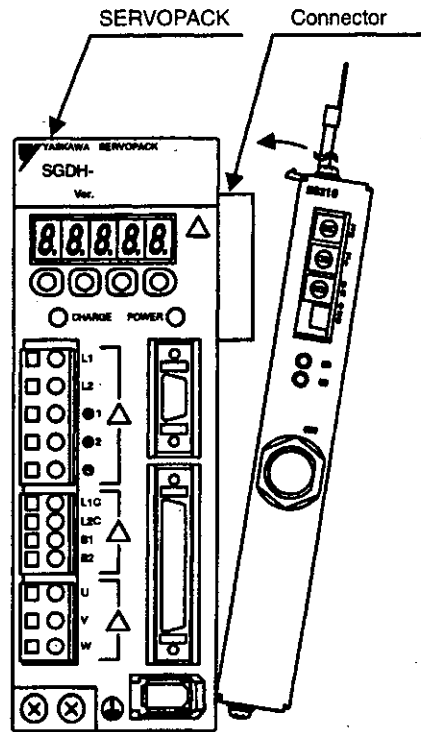

3. For grounding, connect a ground wire of the NS310 Unit to the point marked "G" on the SERVOPACK.

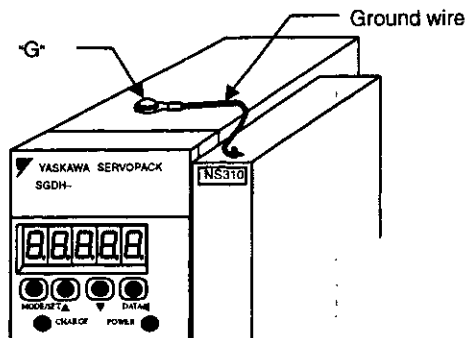

For SERVOPACK 30 W to 5.0 kW

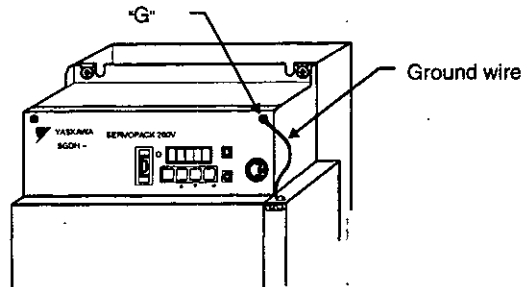

For SERVOPACK 6.0 kW to 7.5 kW

When the NS310 Unit has been mounted correctly, the SERVOPACK will appear as shown in the following diagram.

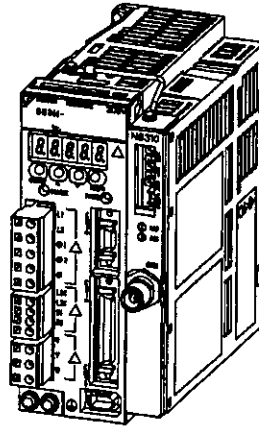

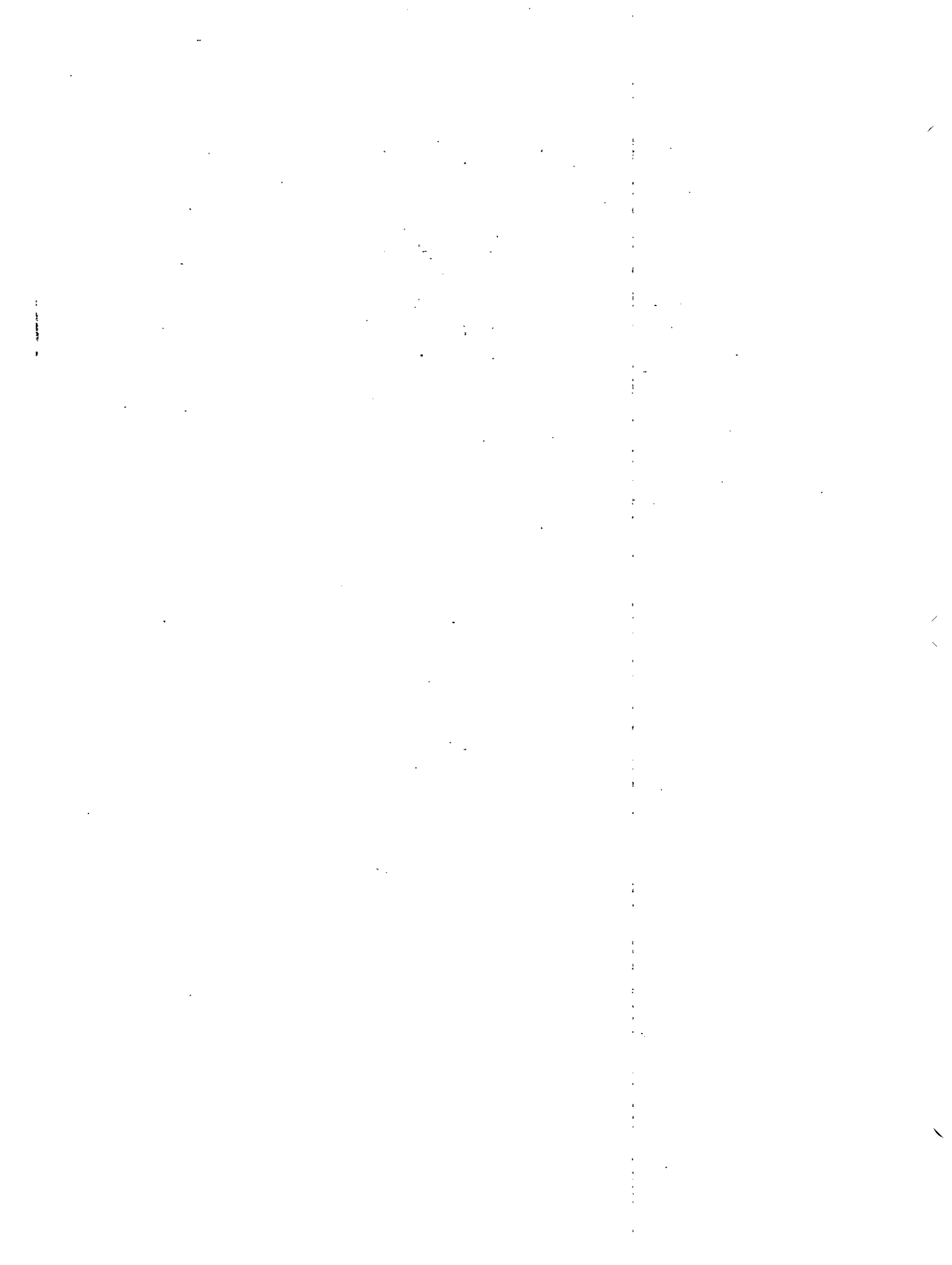

2

Installation



This chapter describes precautions for Σ -II Series product installation.

The SGD_H SERVOPACKs are base-mounted servo amplifiers. Incorrect installation will cause problems. Always observe the installation precautions shown in this chapter.

2.1 Storage Conditions	2 - 2
2.2 Installation Site	2 - 2
2.3 Orientation	2 - 3
2.4 Installation	2 - 4

2.1 Storage Conditions

Store the SERVOPACK within the following temperature range when it is stored with the power cable disconnected.

Temperature range: -20 to 85°C

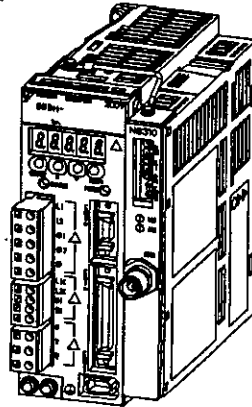

Σ-II Series SGDH SERVOPACK
with NS310 Unit mounted

2.2 Installation Site

Take the following precautions at the installation site.

Situation	Installation Precaution
Installation in a Control Panel	Design the control panel size, unit layout, and cooling method so that the temperature around the SERVOPACK does not exceed 55°C.
Installation Near a Heating Unit	Minimize heat radiated from the heating unit as well as any temperature rise caused by natural convection so that the temperature around the SERVOPACK does not exceed 55°C.
Installation Near a Source of Vibration	Install a vibration isolator beneath the SERVOPACK to avoid subjecting it to vibration.
Installation at a Site Exposed to Corrosive Gas	Corrosive gas does not have an immediate effect on the SERVOPACK, but will eventually cause electronic components and contactor-related devices to malfunction. Take appropriate action to avoid corrosive gas.
Other Situations	Do not install the SERVOPACK in hot or humid locations, or locations subject to excessive dust or iron powder in the air.

2.3 Orientation

Install the SERVOPACK perpendicular to the wall as shown in the figure. The SERVOPACK must be oriented this way because it is designed to be cooled by natural convection or cooling fan.

Secure the SERVOPACK using 2 to 4 mounting holes. The number of holes depends on the SERVOPACK capacity.

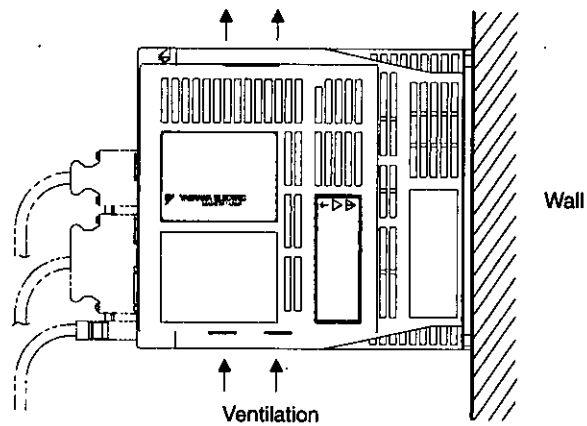

2.4 Installation

Follow the procedure below to install multiple SERVOPACKs side by side in a control panel.

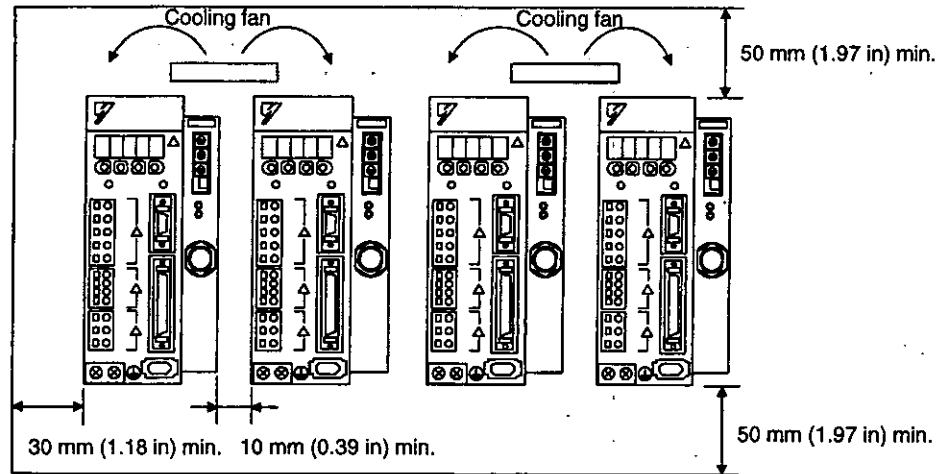

■ SERVOPACK Orientation

Install the SERVOPACK perpendicular to the wall so that the front panel (containing connectors) faces outward.

■ Cooling

As shown in the figure above, provide sufficient space around each SERVOPACK for cooling by cooling fans or natural convection.

■ Side-by-side Installation

When installing SERVOPACKs side by side as shown in the figure above, provide at least 10 mm (0.39 in) between and at least 50 mm (1.97 in) above and below each SERVOPACK. Install cooling fans above the SERVOPACKs to avoid excessive temperature rise and to maintain even temperature inside the control panel.

■ Environmental Conditions in the Control Panel

- Ambient Temperature: 0 to 55°C
- Humidity: 90% or less
- Vibration: 4.9 m/s²
- Condensation and Freezing: None
- Ambient Temperature for Long-term Reliability: 45°C max.

3

Connectors



This chapter describes the procedure used to connect Σ -II Series products to peripheral devices when an NS310 Unit is mounted and gives typical examples of I/O signal connections.

3.1 Connecting to Peripheral Devices	3 - 2
3.1.1 Single-phase (100 V or 200 V) Main Circuit Specifications	3 - 3
3.1.2 Three-phase 200 V Main Circuit Specifications ..	3 - 4
3.2 SERVOPACK Internal Block Diagrams ...	3 - 5
3.3 I/O Signals	3 - 6
3.3.1 Connection Example of I/O Signal Connector (CN1)	3 - 6
3.3.2 I/O Signals Connector (CN1)	3 - 7
3.3.3 I/O Signal Names and Functions	3 - 8
3.3.4 Interface Circuits	3 - 9
3.4 Connections for DeviceNet Communications	3 - 11
3.4.1 DeviceNet Communications Connection Example	3 - 11
3.4.2 DeviceNet Communications Connectors (CN6) ..	3 - 13
3.4.3 Precautions for Wiring DeviceNet Cables	3 - 14
3.4.4 Grounding	3 - 18

3.1 Connecting to Peripheral Devices

This section provides examples of standard Σ -II Series product connections to peripheral devices.

It also briefly explains how to connect each peripheral device.

3.1.1 Single-phase (100 V or 200 V) Main Circuit Specifications

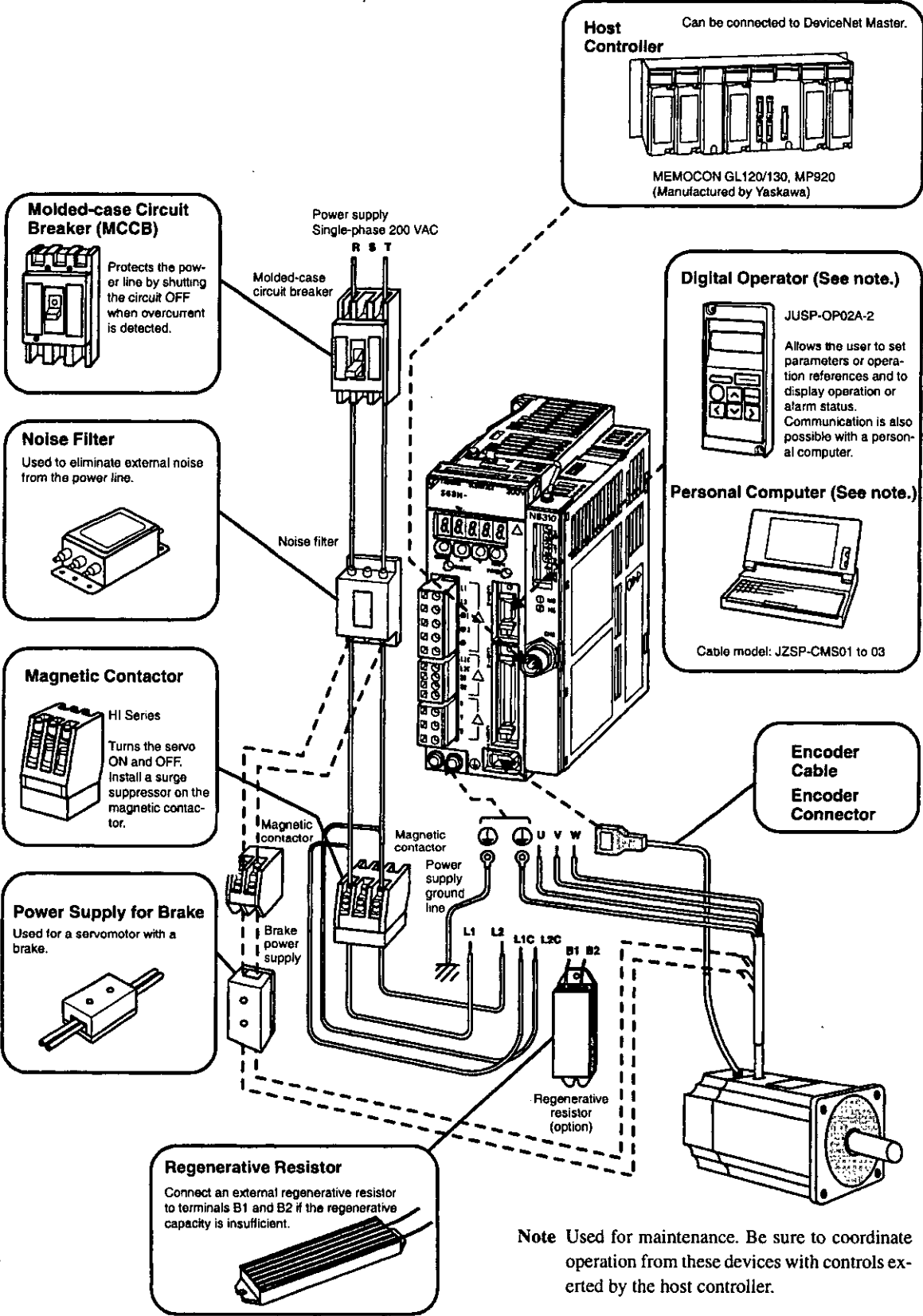

3.1.2 Three-phase 200 V Main Circuit Specifications

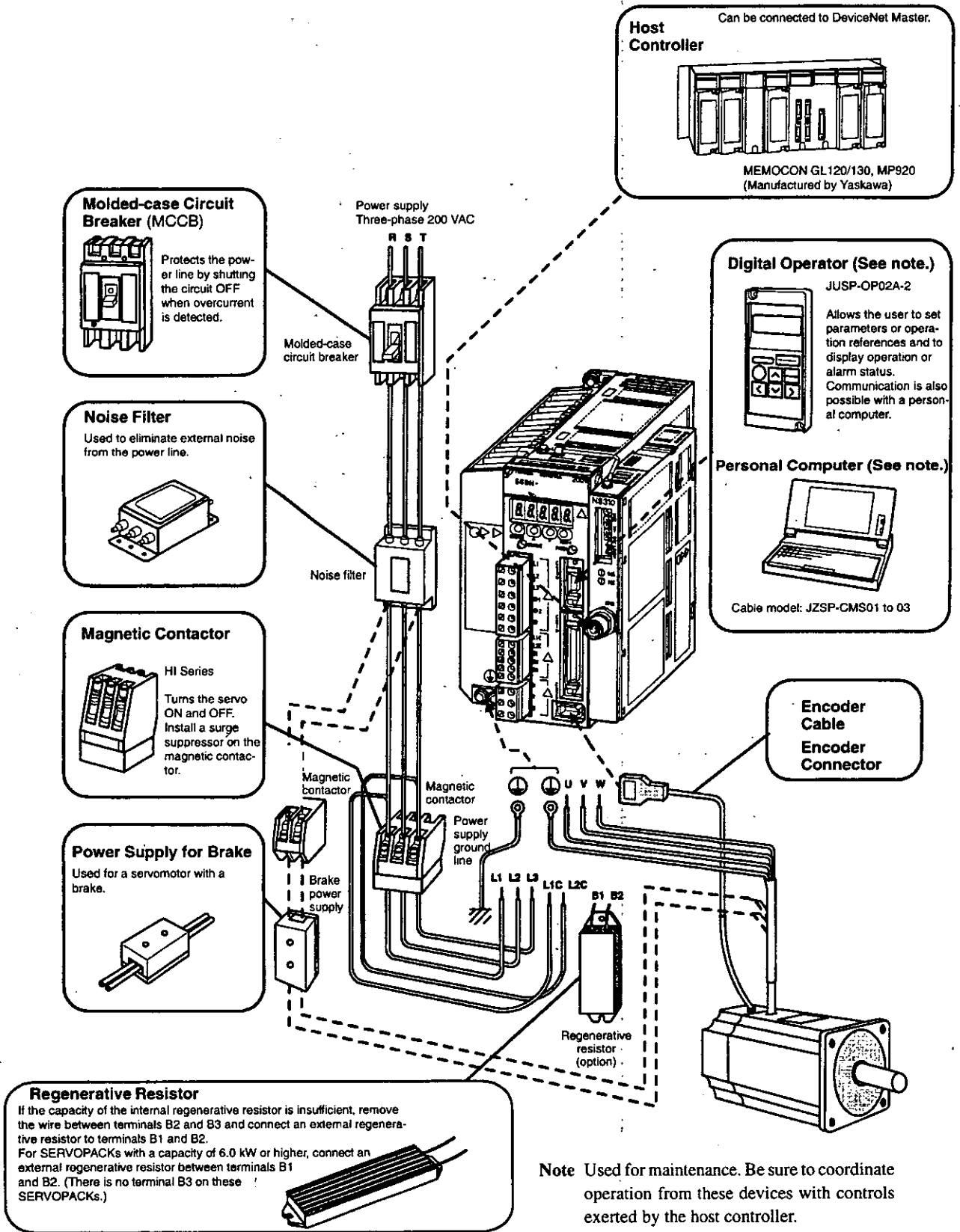

3.2 SERVOPACK Internal Block Diagrams

The following sections show an internal block diagram for the SERVOPACK with an NS310 Unit.

30 to 400 W 200-V and 30 to 200 W 100-V Models

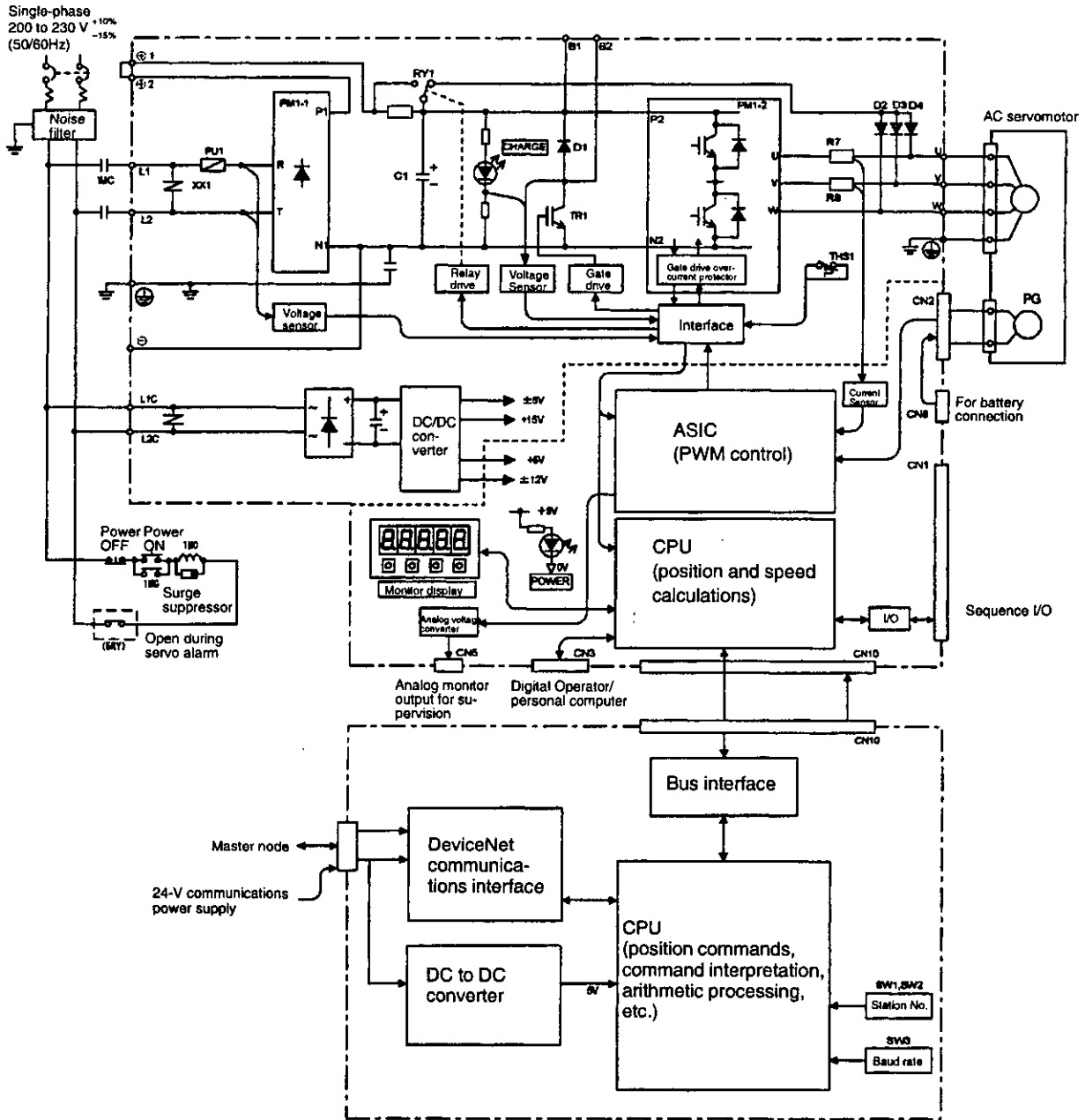

3.3 I/O Signals

This section describes I/O signals for the SERVOPACK with the NS310 Unit.

3.3.1 Connection Example of I/O Signal Connector (CN1)

The following diagram shows a typical example of I/O signal connections.

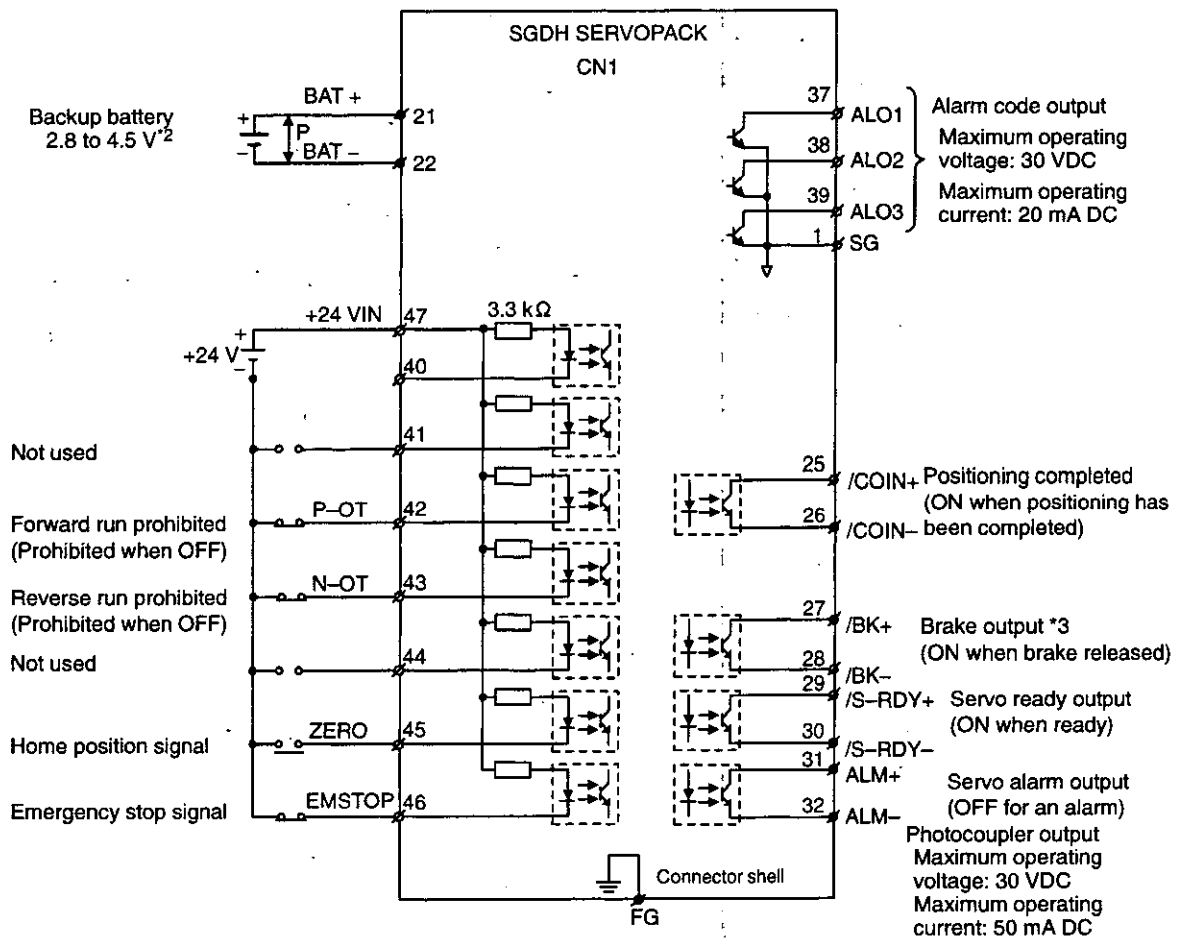

Connect the shield wire to connector shell.

- * 1. †P represents twisted-pair wires.
- * 2. When using an absolute encoder, connect a backup battery only when there is no battery connected to the CN8.
- * 3. Make signal allocations using parameters. (Refer to 6.1.2 Standard Settings for CN1 I/O Signals.)

Figure 3.1 I/O Signal Connections for CN1 Connectors

3.3.2 I/O Signals Connector (CN1)

The following diagram shows the layout of CN1 terminals.

■ CN1 Terminal Layout

2	SG	GND	1	SG	GND	26	/COIN-	Positioning complete output
4	-	-	3	-	-	27	/BK+ (Note 3)	Brake interlock output
6	SG	GND	5	-	-	28	/BK- (Note 3)	Brake interlock output
8	-	-	7	-	-	29	/S-RDY+	Servo ready output
10	SG	GND	9	-	-	30	/S-RDY-	Servo ready output
12	-	-	11	-	-	31	ALM+	Servo alarm output
14	-	-	13	-	-	32	ALM-	Servo alarm output
16	-	-	15	-	-	33	-	-
18	-	-	17	-	-	34	-	-
20	-	-	19	-	-	35	-	-
22	BAT (-)	Battery (-)	21	BAT (+)	Battery (+)	36	-	-
24	-	-	23	-	-	37	AL01	Alarm code output (open-collector output)
			25	/COIN +	Positioning complete output	38	AL02	
						39	AL03	
						40	-	-
						41	-	-
						42	P-OT	Forward drive prohibited input
						43	N-OT	Reverse run prohibited input
						44	-	-
						45	ZERO	Home position signal
						46	EMSTOP	Emergency stop signal
						47	+24VIN	External power supply input
						48	-	-
						49	-	-
						50	-	-

Note 1. Do not use unused terminals for relays.

2. Connect the shield of the I/O signal cable to the connector shell.

The shield is connected to the FG (frame ground) at the SERVOPACK-end connector.

3. Make signal allocations using parameters. (Refer to 6.1.2 *Standard Settings for CN1 I/O Signals.*)

■ CN1 Specifications

Specifications for SERVOPACK Connectors	Applicable Receptacles		
	Soldered	Case	Manufacturer
10250-52A2JL 50-p Right Angle Plug	10150-3000VE	10350-52A0-008	Sumitomo 3M Ltd.

3.3.3 I/O Signal Names and Functions

The following section describes SERVOPACK I/O signal names and functions.

■ Input Signals

Signal Name		Pin No.	Function	
Common	P-OT	42	Forward run prohibited	Overtravel prohibited: Stops servomotor when movable part travels beyond the allowable range of motion.
	N-OT	43	Reverse run prohibited	
	ZERO	45	External latch signals for home position connected.	
	EMSTOP	46	External signal for emergency stop connected.	
	+24VIN	47	Control power supply input for sequence signals: Users must provide the +24-V power supply. Allowable voltage fluctuation range: 11 to 25 V	
	BAT (+) BAT (-)	21 22	Connecting pin for the absolute encoder backup battery. Connect to either CN8 or CN1.	

■ Output Signals

Signal Name		Pin No.	Function
Common	ALM+	31	Servo alarm: Turns OFF when an error is detected.
	ALM-	32	
	/BK+	27	Brake interlock: Output that controls the brake. The brake is released when this signal is ON.
	/BK-	28	
	/S-RDY+	29	Servo ready: Turns ON if there is no servo alarm when the control/main circuit power supply is turned ON.
	/S-RDY-	30	
ALO1	37	Alarm code output: Outputs 3-bit alarm codes.	
ALO2	38	Open-collector: 30 V and 20 mA rating maximum	
ALO3	39 (1)		
	FG	Shell	Connected to frame ground if the shield wire of the I/O signal cable is connected to the connector shell.
Position	/COIN+	25	Positioning completed (output in Position Control Mode): Turns ON when the number of error pulses reaches the set value. The setting is the number of error pulses set in reference units (input pulse units defined by the electronic gear).
	/COIN-	26	

Note 1. Pin numbers in parenthesis () indicate signal grounds.

2. The functions allocated to /BK, /S-RDY, and /COIN can be changed via parameters. The /BK, /S-RDY, and /COIN output signals can be changed to /CLT, /VLT, /TGON, /WARN, or /NEAR signals.

3.3.4 Interface Circuits

The following diagram shows an example of connections between a host controller and the I/O signal for a SERVOPACK.

■ Sequence Input Circuit Interface

The sequence input circuit interface connects through a relay or open-collector transistor circuit. Select a low-current relay, otherwise a faulty contact will result.

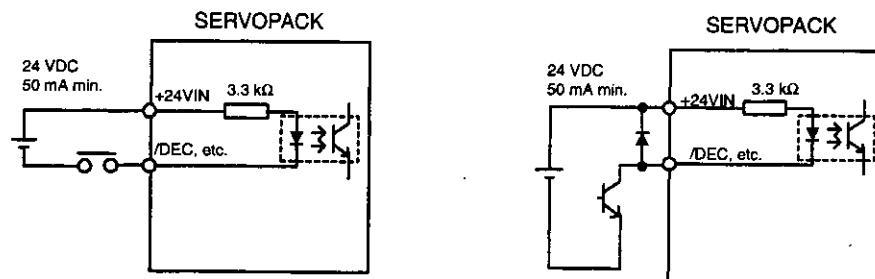

■ Output Circuit Interfaces

Any of the following three types of SERVOPACK output circuits can be used. Form an input circuit at the host controller that matches one of these types.

● Connecting to an Open-collector Output Circuit

Alarm code signals are output from open-collector transistor output circuits.

Connect an open-collector output circuit through a photocoupler, relay, or line receiver circuit.

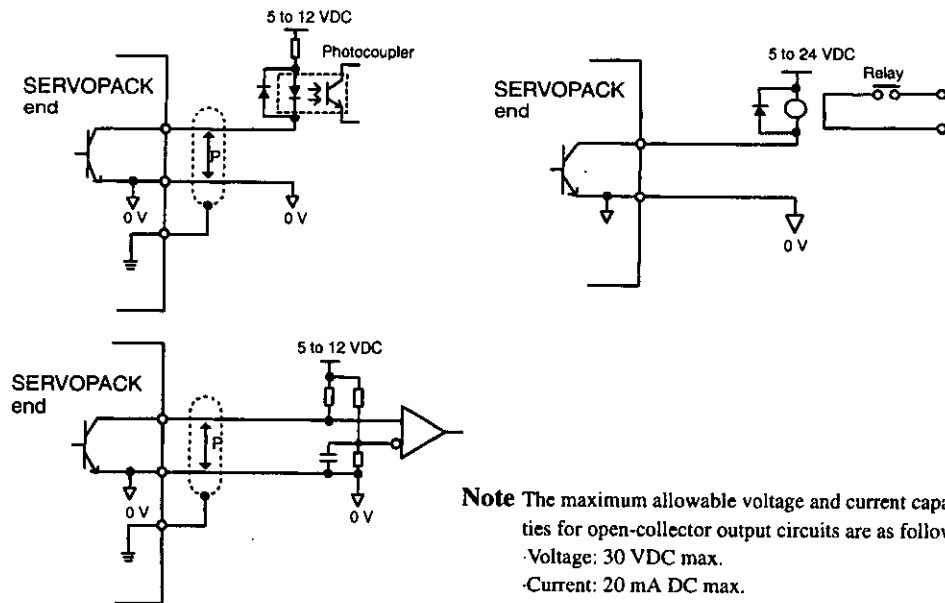

Note The maximum allowable voltage and current capacities for open-collector output circuits are as follows:

- Voltage: 30 VDC max.
- Current: 20 mA DC max.

- Connecting to a Photocoupler Output Circuit

Photocoupler output circuits are used for servo alarm, servo ready, and other sequence output signal circuits.

Connect a photocoupler output circuit through a relay or line receiver circuit.

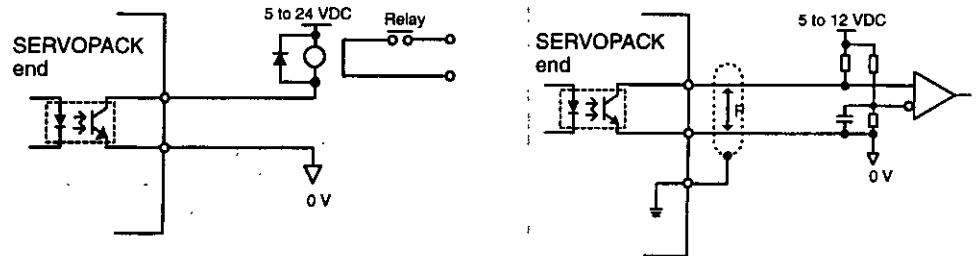

Note The maximum allowable voltage and current capacities for photocoupler output circuits are as follows:

- Voltage: 30 VDC max.
- Current: 50 mA DC max.

3.4 Connections for DeviceNet Communications

This section describes the connection and wiring of connectors for DeviceNet communications.

3.4.1 DeviceNet Communications Connection Example

The following diagram shows an example of connections between a host controller and an NS310 Unit (CN6) using DeviceNet communications cables.

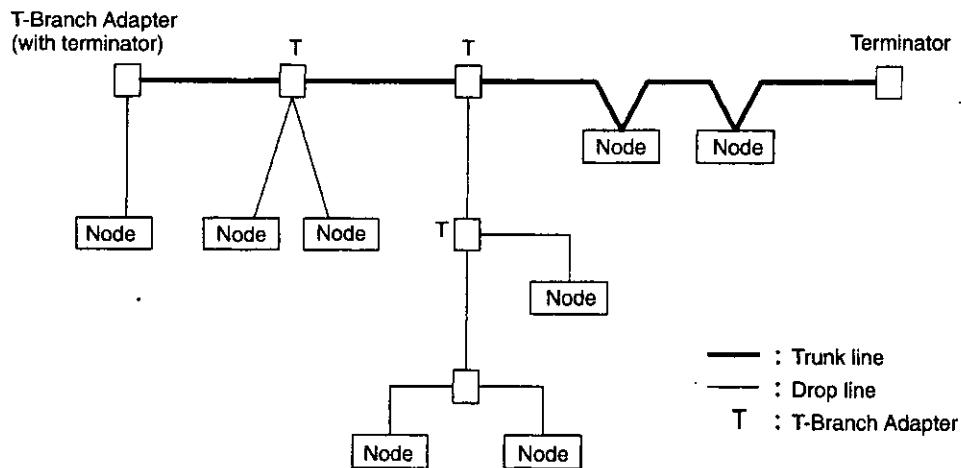

Figure 3.2 Network Connections

■ Configuration Elements

The network is configured from the following elements.

Nodes

A node is either a slave that connects to an NS310 Unit or similar Unit, or the Master that manages the I/O of the slaves. There are no restrictions on the location of the Master or slaves. Any node in *Figure 3.2* can be the Master or a slave.

Trunk Line and Drop Lines

A cable with a terminator on each end is a trunk line. Any cable branching from the trunk line is a drop line.

Connection Methods

A node is connected using the T-branch method or multi-drop method. A T-Branch Adapter is used to connect a node with the T-branch method. A node is directly connected to the trunk line or a drop line with the multi-drop method. Both T-branch and multi-drop methods can be used together in the same network, as shown in *Figure 3.2*.

Terminator

Both ends of the trunk line must connect to terminating resistance to decrease signal reflection and ensure stable network communications.

Communications Power Supply

The communications connector of each node must be provided with a communications power supply through the communications cable for DeviceNet communications.

IMPORTANT

1. The communications cable must be a special DeviceNet cable.
2. Both ends of the trunk line must connect to a terminator.
3. Only DeviceNet devices can be connected to the network. Do not connect any other devices, such as a lightning arrester.

■ Branching from the Trunk Line

There are three methods that can be used to branch from the trunk line.

Single Branching

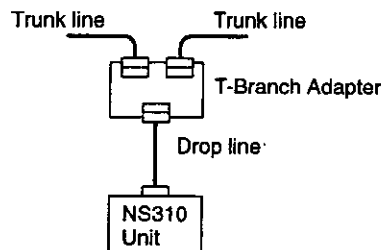

Branching to Three Drop Lines

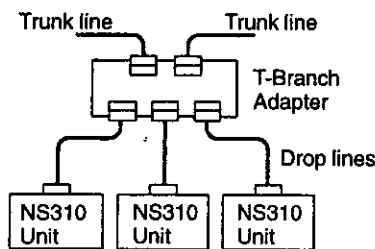

Direct Node Connection

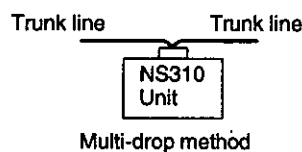

■ Branching from Drop Lines

There are three methods that can be used to branch from drop lines.

Single Branching

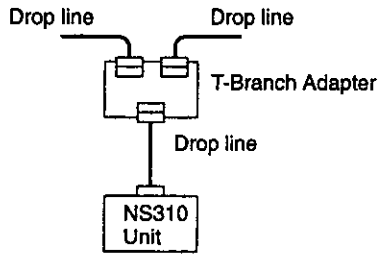

Branching to Three Drop Lines

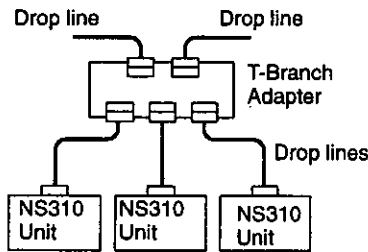

Direct Node Connection

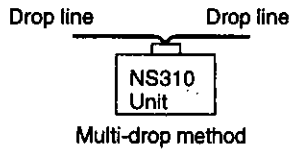

3

3.4.2 DeviceNet Communications Connectors (CN6)

The terminal layout and specifications of the CN6 connectors are shown below.

■ Connector Specifications

The following table shows the connector specifications. These connectors are metal plated with a flange attached.

Name		Model	Manufacturer
Unit side	DeviceNet-compatible Micro-style Connector (male)	CM02-8DR5P	DDK
Cable side	DeviceNet-compatible Micro-style Connector (female)	Not specified.	Not specified.

■ Connector Pin Arrangement

The connector pin arrangement is as shown below.

Pin No. and Code	Symbol	Detail
1	SHIELD	Connect to the wire mesh around the cable.
2	24 V	24 V external communications power supply
3	0 (24 V)	0 V external communications power supply
4	CAN H	CAN bus line dominant H
5	CAN L	CAN bus line dominant L

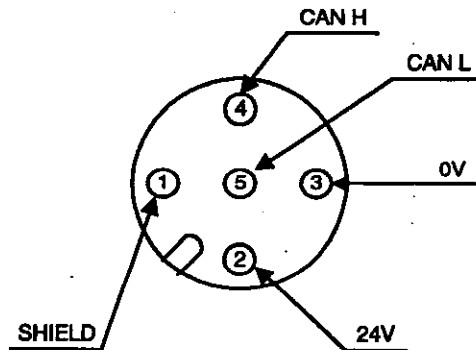

3.4.3 Precautions for Wiring DeviceNet Cables

Observe the following precautions when wiring DeviceNet cables.

■ Maximum Network Length

The maximum network length is either the line length between two nodes located farthest from each other or the line length between the terminators on the ends of the trunk line, whichever is longer.

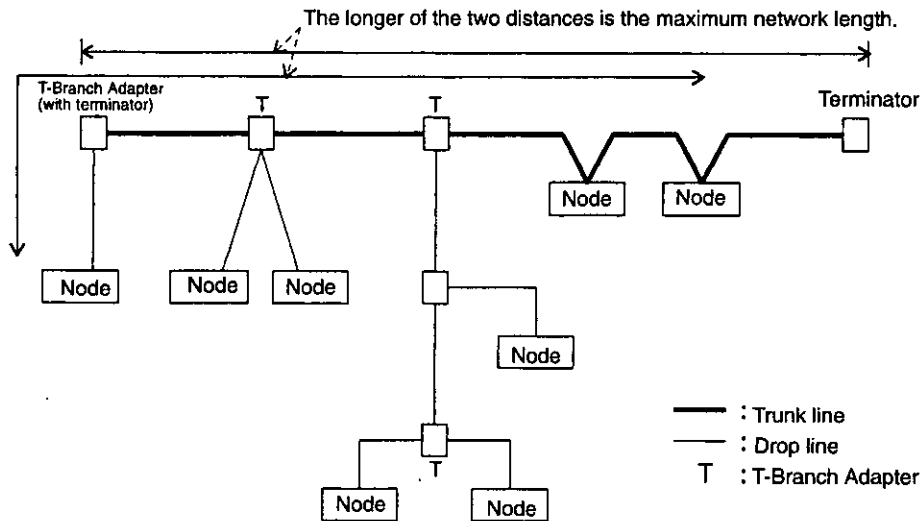

Special DeviceNet cables can be either thick cables or thin cables. The characteristics of each type are given in the following table.

Item	Cable Type	
	Thick Cable	Thin Cable
Signal decay	Slight	Considerable
Communications distance	Long distance	Short distance
Characteristics	Rigid (difficult to bend)	Pliable (bends easily)

The maximum network length is determined by the type of cable, as shown in the following table.

Baud rate (Kbps)	Maximum network length (m)	
	Thick cable	Thin cable
500	100	100
250	250	100
125	500	100



The line connecting two nodes located farthest from each other can use both thick and thin cables provided that the length of each cable satisfies the conditions in the following table.

Baud Rate (Kbps)	Maximum Network Length (m)
500	$L_{THICK} + L_{THIN} \leq 100$
250	$L_{THICK} + 2.5 \times L_{THIN} \leq 250$
125	$L_{THICK} + 5.0 \times L_{THIN} \leq 500$

Note L_{THICK} : Thick cable length L_{THIN} : Thin cable length

■ Drop Line Length

The drop line length is the line length between a branch point on the trunk line to the farthest node that is located on the drop line. The maximum drop line length is 6 m. A drop line can be branched out into other drop lines.

■ Total Drop Line Length

The total drop line length is a total of all drop line lengths.

Length Limits

The total drop line length must be within the allowable range and even then, each drop line must be 6 m or less.

The allowable range of total drop line length varies with the baud rate as shown in the following table.

Baud Rate (Kbps)	Total Drop Line Length (m)
500	39 max.
250	78 max.
125	156 max.

The following example is for a baud rate of 500 Kbps.

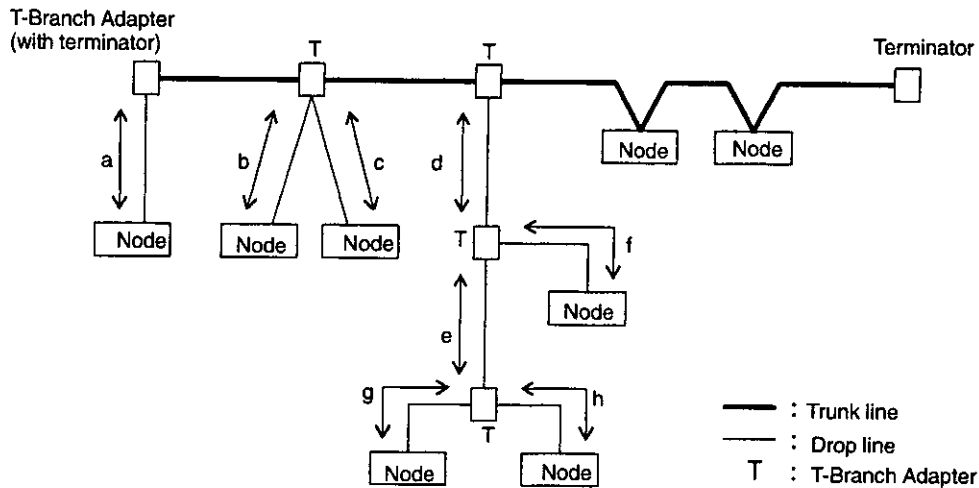

The above example must satisfy the following conditions.

- $a \leq 6 \text{ m}$
- $b \leq 6 \text{ m}$
- $c \leq 6 \text{ m}$
- $d \leq 6 \text{ m}$
- $d+f \leq 6 \text{ m}$
- $d+e+g \leq 6 \text{ m}$
- $d+e+h \leq 6 \text{ m}$

The total drop line length must satisfy the following condition.

- Total drop line length = $a+b+c+d+e+f+g+h \leq 39 \text{ m}$

■ Basic Precautions

Basic precautions are as follows:

- The communications power supply to the network must be 24 VDC.
- The communications power supply must have a sufficient margin in the capacity.
- Connect the communications power supply to the trunk line.
- If many nodes are provided with power from a single power supply, locate the power supply as close as possible to the middle of the trunk line.
- The allowable current flow in a thick cable is 8 A and that in a thin cable is 3 A.
- The power supply capacity for a drop line varies with the drop line length. The longer a drop line is, the lower the maximum current capacity of the drop line will be regardless of the thickness of the drop line. Obtain the allowable current (I) of the drop line (i.e., the allowable current consumption of the drop line and devices connected to it) from the following equation.

$$I=4.57/L$$

I: Allowable current (A)

L: Drop line length (m)

- If only the communications power supply is turned OFF while the network is operating, errors may occur in the nodes that are communicating at that time.

■ Location of Power Supply

The following two types of configuration are possible for the location of the power supply.

Nodes on Both Sides of the Power Supply

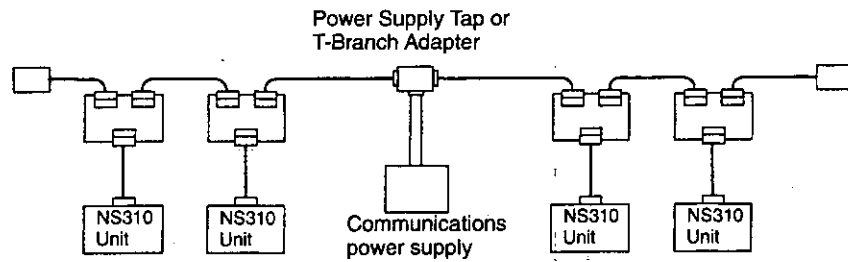

Nodes on One Side of the Power Supply

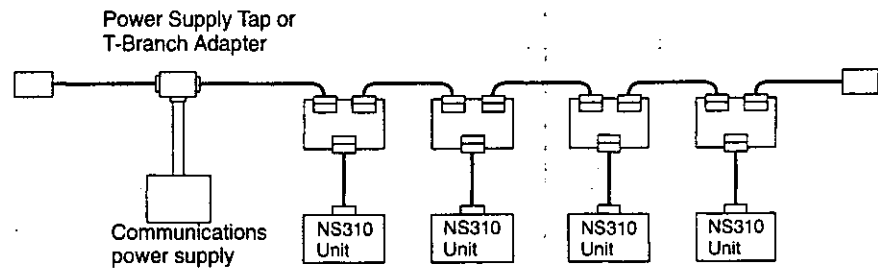

Note The "Nodes on Both Sides of the Power Supply" method is recommended if a single power supply is connected to many nodes.

3.4.4 Grounding

As shown below, connect the shield wire of the cable to the FG terminal of the communications power supply and ground the shield wire to a resistance of 100 Ω or less.

■ Power Supply with Single-point Ground

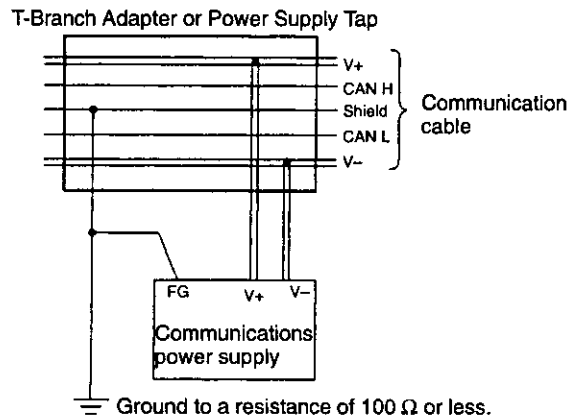

3

■ Power Supply without Ground

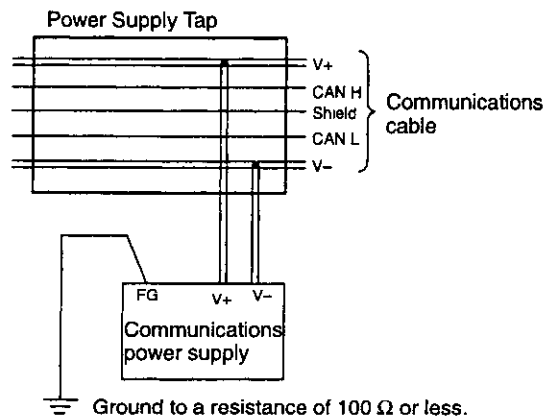

If more than one communications power supply is used, ground only the power supply that is located closest to the middle of the network through the shield wire. Do not ground the power supply through the shield wire at any other point. If more than one communications power supply is connected to the network, connect them using a Power Supply Tap each.

IMPORTANT

1. Power supplies are not counted as nodes.
2. Ground the network to a resistance of 100 Ω or less.
3. Do not ground the network together with servodrivers or inverters.
4. Do not ground the network through the shield wire at more than one point; ground at a single point only.

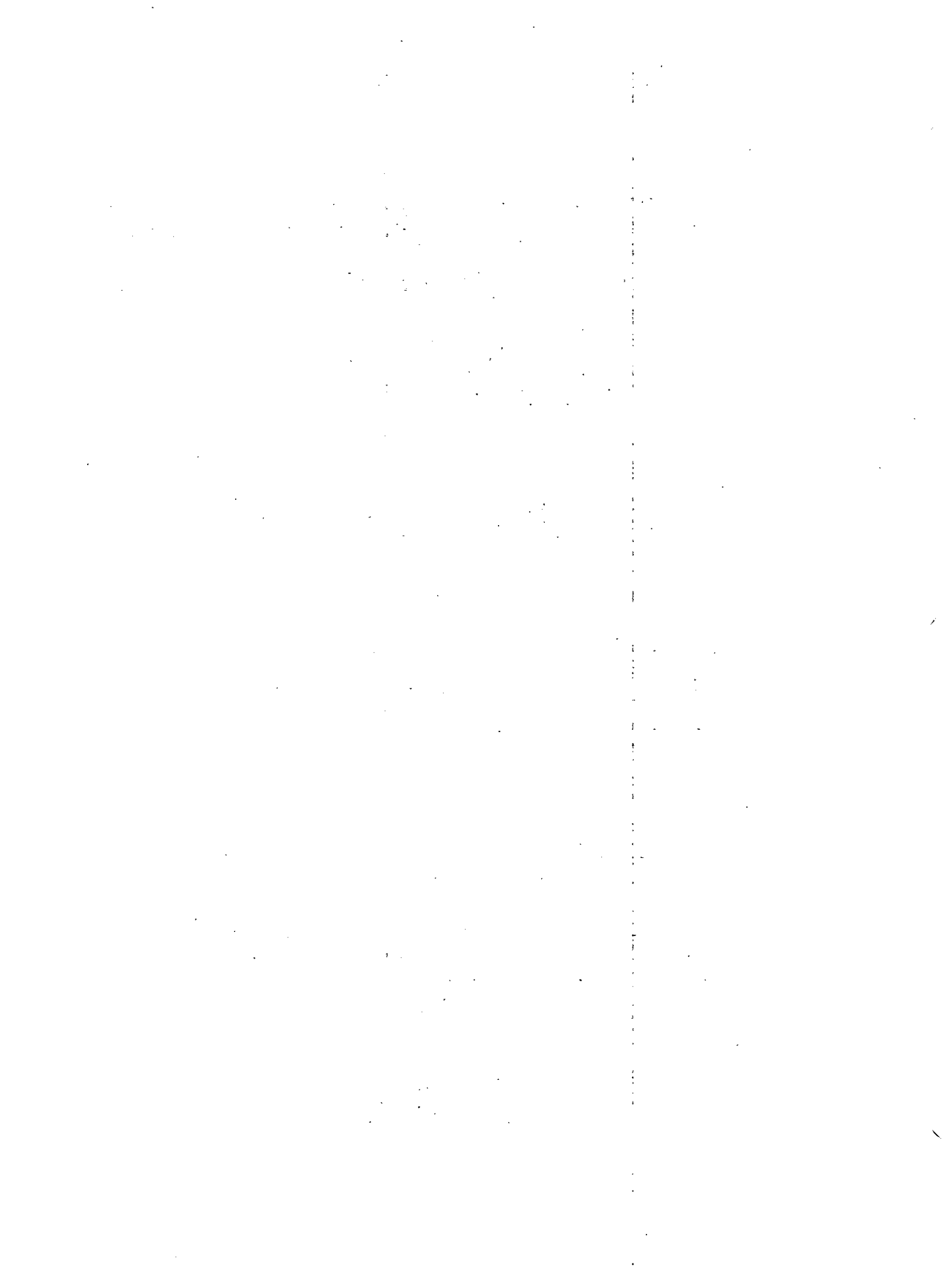

4

Parameter Settings

This chapter explains the outline and details of NS310 parameters.

4.1	Parameter Outline	4 - 2
4.1.1	What Are Parameters?	4 - 2
4.1.2	Parameter Types	4 - 2
4.1.3	Editing Parameters	4 - 3
4.1.4	Effective Timing	4 - 4
4.2	Parameters Tables	4 - 5
4.2.1	Unit Parameters	4 - 5
4.2.2	Homing Parameters	4 - 5
4.2.3	Machine System and Peripheral Device Parameters	4 - 7
4.2.4	Speed, Acceleration, and Deceleration Parameters	4 - 8
4.2.5	Positioning Parameters	4 - 10
4.3	Parameter Details	4 - 11
4.3.1	Unit Parameters	4 - 11
4.3.2	Homing Parameters	4 - 14
4.3.3	Machine System and Peripheral Device Parameters	4 - 18
4.3.4	Speed, Acceleration, and Deceleration Parameters	4 - 24
4.3.5	Positioning Parameters	4 - 35



4.1 Parameter Outline

4.1.1 What Are Parameters?

Parameters is the name given to user constants that are required as the settings used to operate the NS310 Unit. You must set the optimum values for parameters according to the NS310 Unit and the machine to which the SGDh is mounted.

You can edit the NS310 Unit parameters using the NSxxx Setup Tool, DeviceNet Configurator, or host controller. For the NXxxx Setup Tool, refer to *Chapter 7 Using the NSxxx Setup Tool*.

For SGDh parameters, refer to *Chapter 6 Parameters* or the *SGDh User's Manual Design and Maintenance* (SIE-S800-32.2).

4.1.2 Parameter Types

Parameters are classified depending on their purpose as follows:

- Unit parameters
- Homing parameters
- Machine system and peripheral device parameters
- Speed, acceleration, and deceleration parameters
- Positioning parameters

Parameters are further classified according to the priority of the setting, as shown below.

Table 4.1 Parameter Types

Type	Meaning
A	Parameters that must be set even when using the NS310 Unit in standard mode.
B	Parameters that must be set when using the NS310 Unit in special mode.
C	Parameters whose settings hardly ever need to be changed.

4.1.3 Editing Parameters

You can edit parameters using the following methods.

Table 4.2 Methods of Editing Parameters

Tools	Methods	Remarks
NSxxx Setup Tool	Select <i>List</i> From the Parameter Menu to read all the NS310 Unit parameters. After the parameters have been displayed, select the parameters you want to edit, and click the Edit Button to edit the parameters.	All changed parameters are stored in RAM, so they are erased when the power is turned OFF. Use the Module Reset Command to write the parameter data in RAM to the flash ROM.
Master Device or Configurator	You can edit using <i>Explicit Message (Set_Attribute_Single)</i> from the Master Device.	All changed parameters are stored in RAM. Set the Start Trajectory Bit to 1 to write the parameter data in RAM to the flash ROM.

IMPORTANT

If parameters are changed via DeviceNet, they will be automatically written to the flash ROM after the Start Trajectory Command is executed. To lengthen the service life of the flash ROM, however, parameters are not automatically written to the flash ROM when the following parameters are changed.

Object	Attribute	Name
0x25	6	Target Position
	7	Target Speed
	8	Acceleration
	9	Deceleration

Use one of the following methods when it is necessary to be sure that all parameters have been written to flash ROM.

- Execute the Module Reset Command from the NSxxx Setup Tool.
- Execute the Reset Service to the Identity Object via DeviceNet.

Starting positioning and other movement operations will not be delayed when parameters are automatically written to flash ROM.

4.1.4 Effective Timing

Not all parameters edited from the NSxxx Setup Tool or Master Device are effective immediately. Changed parameters are effective at one of the following two times.

Table 4.3 Effective Timing for Parameters

Timing	Control or Processing
Power-up	The values of all parameters are made effective at the following times. <ol style="list-style-type: none"><li data-bbox="703 583 995 615">1. When power is turned ON.<li data-bbox="703 625 1474 657">2. When the <i>Module Reset</i> Command is executed from the NSxxx Setup Tool.
Immediate	The values of changed parameters are made effective immediately. Parameters changed using the <i>Explicit Message</i> from a Master Device, however, will be stored in the Flash ROM at the following times. <ol style="list-style-type: none"><li data-bbox="703 804 1474 835">1. When the <i>Module Reset</i> Command is executed from the NSxxx Setup Tool.<li data-bbox="703 846 1445 877">2. When the Reset Service to the Identity Object is executed via DeviceNet.

4.2 Parameters Tables

The following tables list the parameters.

If using the NSxxx Setup Tool, edit parameters using Pn□□□, which uses the hexadecimal system (e.g., Pn80A). If editing via DeviceNet, edit using the object number and attribute number. The object number uses the hexadecimal system (e.g., 0x64). The attribute number uses the decimal system. Refer to 5.6 *Changing Parameters and Command Blocks* for details.

Object 0x24 (Position Controller Supervisor Object), Object 0x25 (Position Controller Object), and Object 0x64 (Position Parameter Object) include multiple identical parameters. If you edit any one of them, the others will be updated automatically.

4.2.1 Unit Parameters

The unit parameter table is shown below.

Table 4.4 Unit Parameter (Object 0x64)

Object	Attribute	No.	Name	Range	Units	Effective Timing	Default Value	Type
0x64	30	Pn810	Electronic Gear Ratio (Numerator)	1 to 0x7FFFFFFF	---	Power-up	1	B
	31	Pn811	Electronic Gear Ratio (Denominator)	1 to 0x7FFFFFFF	---	Power-up	1	B

4.2.2 Homing Parameters

The homing parameter table is shown below.

Table 4.5 Homing Parameters (Objects 0x24 and 0x25)

Object	Attribute	No.	Name	Range	Units	Effective Timing	Default Value	Type
0x24	11	---	Home Active Level	0, 1	---	Power-up	0	B
0x25	253	---	Home Direction	0, 1	---	Immediate	0	B
	254	---	Home Fast Speed	1 to 4,000,000	step/s	Immediate	10,000	B
	255	---	Home Slow Speed	1 to 4,000,000	step/s	Immediate	5,000	B

Parameter Settings

4.2.2 Homing Parameters

Table 4.6 Homing Parameters (Object 0x64)

Object	Attribute	No.	Name	Range	Units	Effective Timing	Default Value	Type
0x64	11	Pn801	Homing Function Selection	---	---	Immediate	1	B
	13	Pn803	Home Fast Speed for Homing	1 to 240,000	1000 step/min	Immediate	600	B
	14	Pn804	Home Slow Speed for Homing	1 to 240,000	1000 step/min	Immediate	300	B
	15	Pn805	Final Travel Distance for Homing	0 to 99,999,999	step	Immediate	0	B
	17	Pn809	Home Position Offset	-99,999,999 to 99,999,999	step	Immediate	0	B

Note: 1. "Step" means "reference unit." For reference unit details, refer to 4.3.1 Unit Parameters.

2. If you set the reference unit to 0.001 mm, 1,000 step/min. becomes mm/min.

4.2.3 Machine System and Peripheral Device Parameters

The machine system and peripheral device parameter table is shown below.

Table 4.7 Machine System and Peripheral Device Parameters (Object 0x25)

Object	Attribute	No.	Name	Range	Units	Effective Timing	Default Value	Type
0x25	24	---	Reference Direction	0, 1	---	Power-up	0	B
	26	---	Positive Torque Limit	0 to 800	% rated	Immediate	800	C
	27	---	Negative Torque Limit	-800 to 0	% rated	Immediate	-800	C
	49	---	Hardware Limit Action	0, 1, 2	---	Immediate	0	B
	52	---	Software Limit Enable	0, 1	---	Immediate	0	B
	54	---	Positive Software Limit Position	-99,999,999 to 99,999,999	step	Immediate	99999999	B
	55	---	Negative Software Limit Position	-99,999,999 to 99,999,999	step	Immediate	-99999999	B
	231	---	Hardware Limit Enable	0, 1	---	Immediate	0	B
	232	---	Hardware Limit Input Logic	0, 1	---	Immediate	0	B
	241	---	Emergency Stop Action	0, 1	---	Immediate	0	B
	242	---	Emergency Stop Enable	0, 1	---	Immediate	0	B
	243	---	Emergency Stop Logic	0, 1	---	Immediate	0	B

Parameter Settings

4.2.4 Speed, Acceleration, and Deceleration Parameters

Table 4.8 Machine System and Peripheral Device Parameters (Object 0x65)

Object	Attribute	No.	Name	Range	Units	Effective Timing	Default Value	Type
0x64	32	Pn812	Coordinate Type	0, 1	---	Immediate	0	C
	33	Pn813	Command Value per Machine Rotation	1 to 1,500,000	step	Immediate	360,000	C
	34	Pn814	Backlash Compensation	0 to 32,767	step	Immediate	0	C
	35	Pn815	Backlash Direction	0, 1	---	Immediate	0	C
	36	Pn816	Positive Software Limit	±99,999,999	step	Immediate	99999999	B
	37	Pn817	Negative Software Limit	±99,999,999	step	Immediate	-99999999	B
	38	Pn818	Machine Function Selection	0, 1, 2, 3	---	Immediate	0	B
	40	Pn81A	Hardware Limit Action	0, 1, 2	---	Immediate	0	B
	41	Pn81B	Emergency Input Selection Function	0, 1, 2, 3	---	Immediate	0	B
	42	Pn81C	Emergency Stop Action	0	---	Immediate	0	B

Note: 1. "Step" means "reference unit." For reference unit details, refer to 4.3.1 Unit Parameters.

2. If you set the reference unit to 0.001 mm, 1,000 step/min. becomes mm/min.

4.2.4 Speed, Acceleration, and Deceleration Parameters

The table of speed, acceleration, and deceleration parameters is shown below.

Table 4.9 Speed, Acceleration, and Deceleration Parameters (Object 0x25)

Object	Attribute	No.	Name	Range	Units	Effective Timing	Default Value	Type
0x25	7	---	Target Speed	1 to 4,000,000	step/s	Immediate	400,000	B
	8	---	Acceleration	---	step/s ²	Immediate	---	B
	9	---	Deceleration	---	step/s ²	Immediate	---	B
	18	---	Profile Type	0, 1, 2, 240 to 245	---	Immediate	0	B
	19	---	Profile Gain	4 to 1000	ms	Immediate	25	B

Table 4.10 Speed, Acceleration, and Deceleration Parameters (Object 0x64)

Object	Attribute	No.	Name	Range	Units	Effective Timing	Default Value	Type
0x64	51	Pn821	Feed Speed for Positioning	1 to 240,000	1000 step/min	Immediate	24,000	B
	52	Pn822	Accel/Decel Time Constant for Positioning	1 to 10,000	ms	Immediate	100	B
	53	Pn823	Deceleration Time Constant for Asymmetric	1 to 10,000	ms	Immediate	100	C
	54	Pn824	Switch Speed of Second Accel/Decel	1 to 240,000	1000 step/min	Immediate	24,000	C
	55	Pn825	Accel/Decel Time Constant of Second Accel/Decel	1 to 10,000	ms	Immediate	100	C
	56	Pn826	Accel/Decel Type for Positioning	0, 1, 2, 3	---	Immediate	0	B
	58	Pn829	Filter Selection	0, 1, 2, 3	---	Immediate	0	B
	60	Pn831	Feed Speed for JOG	1 to 240,000	1000 step/min	Immediate	24,000	B
	61	Pn832	Accel/Decel Time Constant for JOG	1 to 10,000	ms	Immediate	100	B
	62	Pn833	Deceleration Time Constant of Asymmetric for JOG	1 to 10,000	ms	Immediate	100	C
	63	Pn834	Switch Speed of Second Accel/Decel for JOG	1 to 240,000	1000 step/min	Immediate	24,000	C
	64	Pn835	Accel/Decel Time Constant of Second Accel/Decel for JOG	1 to 10,000	ms	Immediate	100	C
	65	Pn836	Accel/Decel Type for JOG	0, 1, 2, 3	---	Immediate	0	B
	70	Pn840	Time Constant for Exponential Curve	2 to 1,000	ms	Immediate	2	C
71	Pn841	Bias Speed	1 to 240,000	1000 step/min	Immediate	24,000	C	

Parameter Settings

4.2.5 Positioning Parameters

Object	Attribute	No.	Name	Range	Units	Effective Timing	Default Value	Type
0x64	72	Pn842	Time Constant of Moving Average	4 to 4,000	ms	Immediate	25	C
	73	Pn843	Maximum Feed Speed	1 to 240,000	1000 step/min	Immediate	24,000	B

Note: 1. "Step" means "reference unit." For reference unit details, refer to 4.3.1 Unit Parameters.

2. If you set the reference unit to 0.001 mm, 1,000 step/min. becomes mm/min.

4.2.5 Positioning Parameters

The Positioning parameter table is shown below.

Table 4.11 Positioning Parameters (Object 0x25)

Object	Attribute	No.	Name	Range	Units	Effective Timing	Default Value	Type
0x25	30	---	Kp	1 to 2,000	1/s	Immediate	40	B
	38	---	Position Deadband	0 to 255	step	Immediate	5	A
	45	---	Max. Dynamic Following Error	256 to 8388352	step	Immediate	262,144	B

Table 4.12 Positioning Parameters (Object 0x64)

Object	Attribute	No.	Name	Range	Units	Effective Timing	Default Value	Type
0x64	90	Pn850	Positioning Deadband	0 to 255	step	Immediate	5	A
	91	Pn851	Positioning Timeout	0 to 100,000	ms	Immediate	0	A

Note: 1. "Step" means "reference unit." For reference unit details, refer to 4.3.1 Unit Parameters.

2. If you set the reference unit to 0.001 mm, 1,000 step/min. becomes mm/min.

4.3 Parameter Details

4.3.1 Unit Parameters

The unit for performing positioning using an NS310 Unit is determined by the following two parameters.

Table 4.13 Unit Parameter (Object 0x65)

Object	Attribute	No.	Name	Range	Units	Effective Timing	Default Value	Type
0x64	30	Pn810	Electronic gear (numerator)	1 to 0xFFFFFFFF	---	Power-up	1	B
	31	Pn811	Electronic gear (denominator)	1 to 0xFFFFFFFF	---	Power-up	1	B

The Electronic Gear Function can be used to set the position command units equal to the amount of encoder pulses. The host controller can generate position commands in more familiar user-defined units such as millimeters or inches.

■ Not Using the Electronic Gear

If not using the electronic gear, set Pn810 and Pn811 to 1 (initial value). This will set the reference unit to 1 pulse, so you must calculate the scale position units using the host controller.

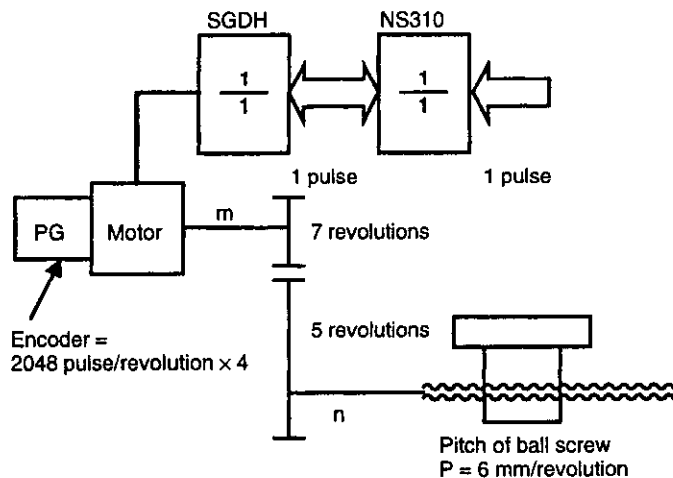

IMPORTANT

Reference unit is the smallest increment of a position command. In this manual, the reference unit is called a step. If you are not using the electronic gear, the setting will be as follows:

- 1 (pulse) = 1 (step)

■ **Electronic Gear Settings When Using a Ball Screw**

If using a ball screw, first check the following specifications.

- Number of Encoder pulses
- Gear ratio
- Ball screw pitch

System Example

The following system example shows the formulas when the reference unit is set to 0.001 mm.

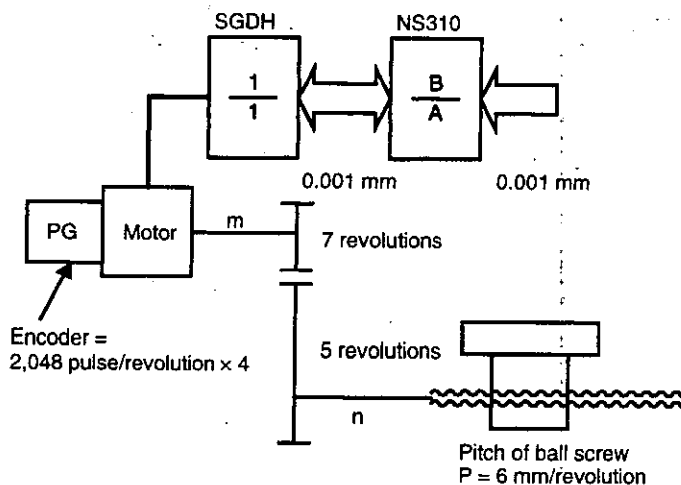

- $REV = \frac{\text{Travel distance of load per revolution (mm)}}{\text{Reference unit (mm)}} = \frac{6 \text{ mm}}{0.001 \text{ mm}} = 6000$
- $A = (REV) \times \{\text{Gear ratio (load rev.)}\} = 6000 \times 5 = 30000$
- $B = (\text{Encoder pulses}) \times (\text{Encoder multiplier}) \times \{\text{Gear ratio (motor rev.)}\} = 2048 \times 4 \times 7 = 57344$
- $B/A = 57344/30000 = 1.911$

Perform three checks (important limitations of gear valves) below.

- $A \leq 2,147,483,647$
- $B \leq 2,147,483,647$
- $100 \geq B/A \geq 0.01$

By storing the value of A in Pn811 and the value of B in Pn810, you can use the Electronic Gear function. The reference unit is set to 0.001 mm. Cycle the power to enable the parameter settings. After you have changed the parameter, execute the Module Reset Command or the Reset Service to the Identity Object.

The NS310 Unit uses an algorithm to ensure accurate conversion of position commands without any accumulated error. The value of B/A may be any real number between 100 and 0.01 inclusive.

IMPORTANT

- Setting B/A outside the range 0.01 to 100 may result in a misoperation. Make sure to set B and A within this range.
- In this manual, when the reference unit is set to 0.001 mm, the following formulas are applied.
 - Position: 0.001 (mm) = 1 (step)
 - Speed: 1 (mm/s) = 1 (1,000 steps/s)

■ Electronic Gear Settings when Using a Rotary Table

If using a rotary table, first check the following specifications.

- Number of Encoder pulses
- Gear ratio

System Example

The following system example shows the formulas when the reference unit is set to 0.001°.

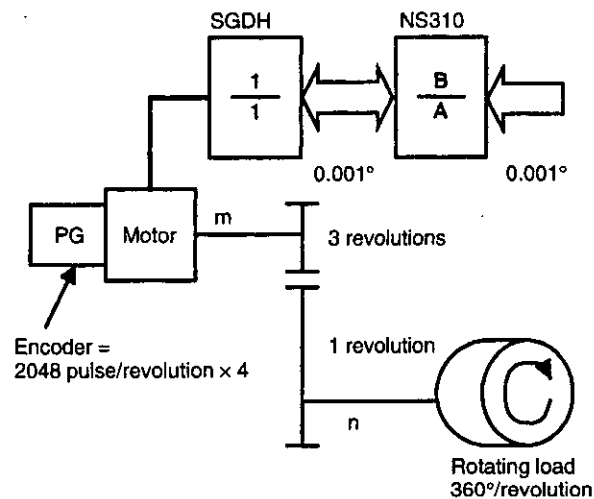

- $REV = 360^\circ / 0.001^\circ = 36000$
- $A = REV \times \{\text{Gear Ratio (load rev.)}\} = 36000 \times 1 = 36000$
- $B = (\text{Encoder pulses}) \times (\text{Encoder multiplier}) \times \{\text{Gear ratio (motor rev.)}\} = 2048 \times 4 \times 3 = 24576$
- $B/A = 24576 / 36000 = 0.683$

Perform three checks (important limitations of gear valves) below.

- $A \leq 2,147,483,647$
- $B \leq 2,147,483,647$
- $100 \geq B/A \geq 0.01$

By storing the value of A in Pn811 and the value of B in Pn810, you can use the Electronic Gear function. The reference unit is set to 0.001°. Cycle the power to enable the parameter settings. After you have changed the parameter, execute the Module Reset Command or the Reset Service to the Identity Object.

IMPORTANT

- Setting B/A outside the range 0.01 to 100 may result in a misoperation. Make sure to set B and A within this range.
- In this manual, when the reference unit is set to 0.001° , the following formulas are applied.
 - Position: $0.001 (^\circ) = 1$ (step)
 - Speed: $1 (^\circ/s) = 1$ (1,000 steps/s)

4.3.2 Homing Parameters

■ Homing Types

The following three types of homing are supported.

Type 00

This homing type returns to the home position using the home position signal and the phase C of the Encoder. The outline of the operation is as follows:

- The axis travels in the direction specified as home direction at home fast speed.
- When the home position signal changes, the axis decelerates, and travels in the opposite direction at home slow speed.
- When the home position signal changes again, the axis continues to travel in the same direction as before until the phase C is detected.
- When the phase C is detected, that position becomes the home position.

◀EXAMPLE▶

Final Travel Distance for Homing = 0

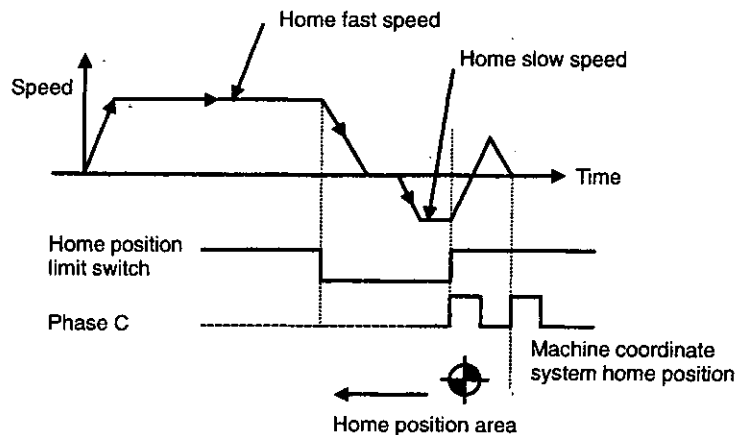

Figure 4.1 Type 00 Homing

Type 0x01

This homing type returns to the home position using the home position signal only. The outline of the operation is as follows:

- The axis travels in the direction specified as home direction at home fast speed.

2. When the home position signal changes, axis decelerates, and travels in the opposite direction at home slow speed.
3. The axis stops at the position where the home position signal changed, and that position becomes the home position.

◀EXAMPLE▶

Final Travel Distance for Homing = 0

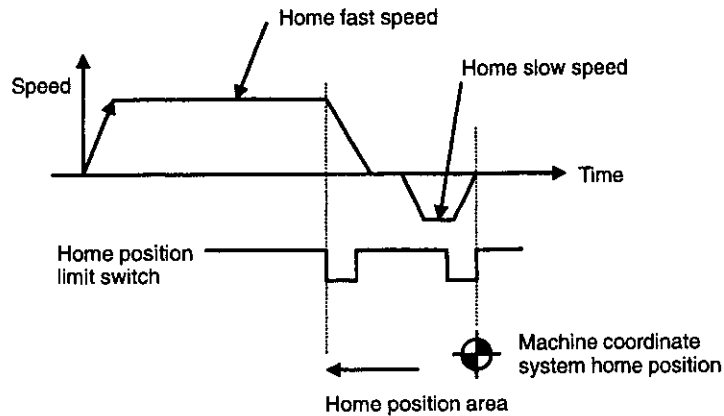

Figure 4.2 Type 01 Homing

◀EXAMPLE▶

Final Travel Distance for Homing > 0

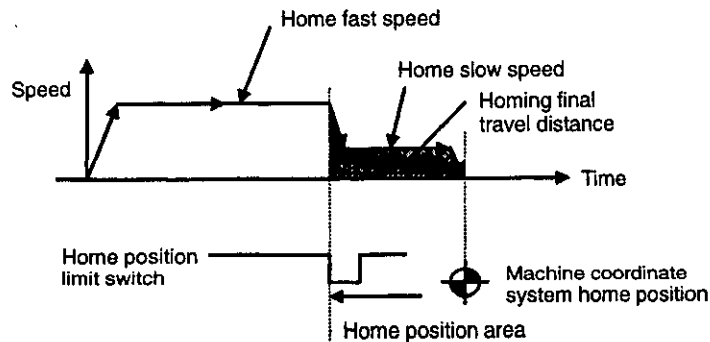

Figure 4.3 Type 01 Homing with Final Travel Distance

Type 0x03

This homing type returns to the home position using the phase C of the Encoder only. The outline of the operation is as follows:

1. The axis travels in the direction specified as home direction at home fast speed.
2. When the phase C is detected, axis decelerates, and travels in the opposite direction at home slow speed.
3. The axis stops at the position where the phase C is detected, and that position becomes the home position.

◀EXAMPLE▶

Final Travel Distance for Homing = 0

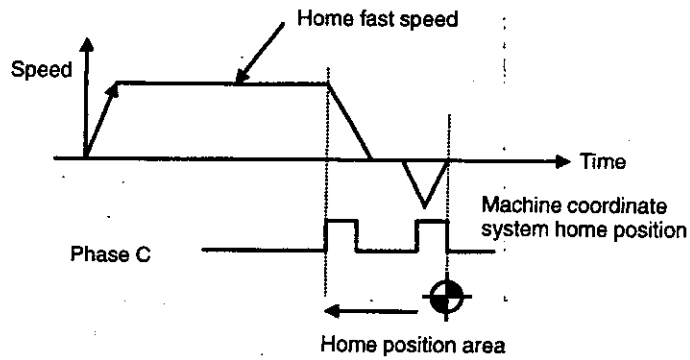

Figure 4.4 Type 03 Homing

◀EXAMPLE▶

Final Travel Distance for Homing > 0

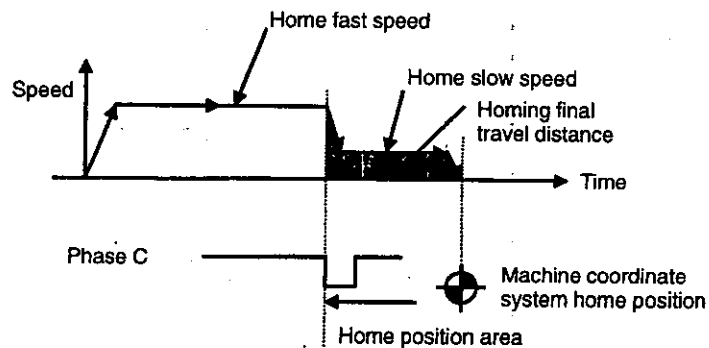

Figure 4.5 Type 03 Homing with Final Travel Distance

The details of parameters relating to homing are given below.

■ **Parameter Details (Objects 0x24 and 0x25)**

Home Active Level (Object: 0x24, Attribute: 11)

Use the Home Active Level to set the activity level of the home position signal.

Setting	Description
0	Active Low
1	Active High

Home Direction (Object: 0x25, Attribute: 253)

Use the Home Direction to set the travel direction when homing starts. If this parameter is changed, the Homing Direction Setting (Object: 0x64, Attribute: 11; Pn801: bit 0) will also be changed automatically.

Setting	Description
0	Negative Direction
1	Positive Direction

Home Fast Speed (Object: 0x25, Attribute: 254)

Use the Home Fast Speed to set the home fast speed during homing. The setting unit is step/s.

If this parameter is changed, the Home Fast Speed for Homing (Object: 0x64, Attribute: 13; Pn803) will also be changed automatically.

The conversion is performed using the following formula.

- Home Fast Speed (step/s) = Home Fast Speed for Homing (1000 step/min) \times 1000 \div 60

Home Slow Speed (Object: 0x25, Attribute: 255)

Use the Home Slow Speed to set the home slow speed during homing. The setting unit is step/s.

If this parameter is changed, the home slow speed for Homing (Object: 0x64, Attribute: 14; Pn804) will also be changed automatically.

The conversion is performed using the following formula.

- Home Slow Speed (step/s) = Home Slow Speed for Homing (1000 step/min) \times 1000 \div 60

■ Parameter Details (Object 0x64)

Homing Function Selection (Object: 0x64, Attribute: 11; Pn801)

The Homing Function Selection has the following bit settings.

Table 4.14 Homing Function Selection

Bit	Name	Description	Default
00	Homing Direction Setting*	0: Positive Direction 1: Negative Direction	0
01 to 15	Reserved	Do not change	0

* Set the travel direction when homing starts.

Home Fast Speed for Homing (Object: 0x64, Attribute: 13; Pn803)

Use the Home Fast Speed for Homing to set the Home Fast Speed during the homing. The setting unit is 1,000 step/min.

If this parameter is changed, the Home Fast Speed (Object: 0x25, Attribute: 254) will also be changed automatically.

The conversion is performed using the following formula.

- Home Fast Speed (step/s) = Home Fast Speed for Homing (1,000 step/min) \times 1000 \div 60

Home Slow Speed for Homing (Object: 0x64, Attribute: 14; Pn804)

Use the Home Slow Speed for Homing to set the home slow speed during the homing. The setting unit is 1,000 step/min.

If this parameter is changed, the Home Slow Speed (Object: 0x25, Attribute: 255) will also be changed automatically.

The conversion is performed using the following formula.

- Home Slow Speed (step/s) = Home Slow Speed for Homing (1,000 step/min) × 1000 ÷ 60

Final Travel Distance for Homing (Object: 0x64, Attribute: 15; Pn805)

Use the Final Travel Distance for Homing to set the distance from the position where the phase C and home position signal were detected to the machine home position. The setting unit is step.

4.3.3 Machine System and Peripheral Device Parameters

The details of parameters relating to the machine system and peripheral devices are given below.

■ Parameter Details (Object 0x25)

Reference Direction (Object: 0x25, Attribute: 24)

Use the Reference Direction to set the rotation direction of the motor.

Table 4.15 Reference Direction

Setting	Description
0	CW (from motor shaft side): Positive Direction
1	CCW (from motor shaft side): Positive Direction

Positive Torque Limit (Object: 0x25, Attribute: 26)

Use the Positive Torque Limit to set the positive maximum output torque to protect the equipment or workpiece.

The setting unit is % rated torque. Make the setting between 0 and 800.

If this parameter is changed, the Forward Torque Limit (Object: 0x66, Attribute: 142; Pn402) will also be changed automatically.

Negative Torque Limit (Object: 0x25, Attribute: 27)

Use the Negative Torque Limit to set the negative maximum output torque to protect the equipment or workpiece.

The setting unit is % rated torque. Make setting between -800 to 0.

If this parameter is changed, the Reverse Torque Limit (Object: 0x66, Attribute: 143; Pn403) will also be changed automatically.

Hardware Limit Action (Object: 0x25, Attribute: 49)

Use the Hardware Limit Action to set the operation of the NS310 Unit when a hardware limit is reached. The operations supported by the NS310 Unit are given in the table below.

If this parameter is changed, the Hardware Limit Action (Object: 0x64, Attribute: 40; Pn81A) will also be changed automatically.

Table 4.16 Hardware Limit Action

Setting	Description
0	Servo OFF
1	Hard Stop
2	Smooth Stop
3 to 255	Reserved

Software Limit Enable (Object: 0x25, Attribute: 52)

Use the Software Limit Enable to set whether to use the software limit function. If this function is used, when the motor position exceeds the limit that has been set, the motor will stop.

If this parameter is changed, the Machine Function Selection (Object: 0x64, Attribute: 38; Pn818) will also be changed automatically.

Table 4.17 Software Limit Enable

Setting	Description
0	Disable
1	Enable

Positive Software Limit Position (Object: 0x25, Attribute: 54)

Use the Positive Software Limit Position to set the position of the positive software limit. The setting unit is reference unit. Make the setting between -99,999,999 and 99,999,999.

If this parameter is changed, the Positive Software Limit (Object: 0x64, Attribute: 36; Pn816) will also be changed automatically.

Negative Software Limit Position (Object: 0x25, Attribute: 55)

Use the Negative Software Limit Position to set the position of the negative software limit. The setting unit is reference unit. Make the setting between -99,999,999 and 99,999,999.

If this parameter is changed, the Negative Software Limit (Object: 0x64, Attribute: 37; Pn817) will also be changed automatically.

Hardware Limit Enable (Object: 0x25, Attribute: 231)

Use the Hardware Limit Enable to set whether to use the hardware limit function. If this function is used, when a limit switch that has been connected changes its status, the motor will stop.

If this parameter is changed, the Hardware Limit Enable (Object: 0x64, Attribute: 39; Pn819) will also be changed automatically.

Table 4.18 Hardware Limit Enable

Setting	Description
0	Disable
1	Enable

Hardware Limit Input Logic (Object: 0x25, Attribute: 232)

Use the Hardware Limit Input Logic to set the input logic of the external signal for the hardware limit function.

Table 4.19 Hardware Limit Input Logic

Setting	Description
0	Active Low
1	Active High

Emergency Stop Action (Object: 0x25, Attribute: 241)

Use the Emergency Stop Action to set the operation of the emergency stop.

If this parameter is changed, the Emergency Stop Action (Object: 0x64, Attribute: 42; Pn81C) will also be changed automatically.

Table 4.20 Emergency Stop Action

Setting	Description
0	Hard Stop and Servo OFF
1 to 255	Reserved

Emergency Stop Enable (Object: 0x25, Attribute: 242)

Use the Emergency Stop Enable to set whether to use the Emergency Stop Action.

If this parameter is changed, the Emergency Input Function Selection (Object: 0x64, Attribute: 41; Pn81B) will also be changed automatically.

Table 4.21 Emergency Stop Enable

Bit 0	Description
0	Disable
1	Enable

Emergency Stop Logic (Object: 0x25, Attribute: 243)

Use the Emergency Stop Logic to set the input logic of the Emergency Stop signal.

If this parameter is changed, the Emergency Input Function Selection (Object: 0x64, Attribute: 41; Pn81B) will also be changed automatically.

Table 4.22 Emergency Stop Logic

Setting	Description
0	Active Low
1	Active High

■ Parameter Details (Object 0x64)

Coordinate Type (Object: 0x64, Attribute: 32; Pn812)

Use the Coordinate Type to set whether to use the NS310 Unit as a linear axis or rotary axis.

Table 4.23 Coordinate Type

Setting	Description
0	The linear axis is designated. The unit of current value data: mm, etc.
1	The rotary axis is designated. The unit of current value data: degrees

Command Value per Machine Rotation (Object: 0x64, Attribute: 33; Pn813)

Use the Command Value per Machine Rotation to set the reference unit for one machine rotation. This parameter is enabled only when the Coordinate Type is set to rotary axis. If this parameter is not set correctly, when the machine performs a 360° rotation, the current position will not be reset to 0°, so be careful.

The setting unit is reference unit. The initial value is 360,000.

Backlash Compensation (Object: 0x64, Attribute: 34; Pn814)

Use the Backlash Compensation to set the amount of backlash compensation.

Backlash Compensation Direction (Object: 0x64, Attribute: 35; Pn815)

Use the Backlash Compensation Direction to set the direction of the backlash compensation.

Normally, set this parameter in the opposite direction to the home direction.

Table 4.24 Backlash Compensation Direction

Setting	Description
0	Positive Direction
1	Negative Direction

Positive Software Limit (Object: 0x64, Attribute: 36; Pn816)

Use the Positive Software Limit to set the software limit in the positive direction. The setting unit is reference unit. Make the setting between -99,999,999 and 99,999,999.

If this parameter is changed, the Positive Software Limit Position (Object: 0x25, Attribute: 54) will also be changed automatically.

Negative Software Limit (Object: 0x64, Attribute: 37; Pn817)

Use the Negative Software Limit to set the software limit in the negative direction. The setting unit is reference unit. Make the setting between -99,999,999 and 99,999,999.

If this parameter is changed, the Negative Software Limit Position (Object: 0x25, Attribute: 55) will also be changed automatically.

Machine Function Selection (Object: 0x64, Attribute: 38; Pn818)

Use the Machine Function Selection to set whether to use the software limit functions and the Backlash Compensation functions.

If this parameter is changed, Software Limit Enable (Object: 0x25, Attribute: 52) will also be changed automatically.

Table 4.25 Machine Function Selection

Bit	Description
0	0: Software Limit Function Selection is disable. 1: Software Limit Function Selection is enable.
1	0: Backlash Compensation Function Selection is disable. 1: Backlash Compensation Function Selection is enable.

Hardware Limit Action (Object: 0x64, Attribute: 40; Pn81A)

Use the Hardware Limit Action to set the operation of the NS310 Unit when a hardware limit is reached.

If this parameter is changed, the Hardware Limit Action (Object: 0x25, Attribute: 49) will also be changed automatically.

Table 4.26 Hardware Limit Action

Setting	Description
0	Servo OFF
1	Hard Stop
2	Smooth Stop
3 to 255	Reserved

Emergency Input Function Selection (Object: 0x64, Attribute: 41; Pn81B)

Use the Emergency Input Function Selection to set whether to use the emergency stop function and the input logic of emergency stop signal.

If this parameter is changed, the Emergency Stop Enable (Object: 0x25, Attribute: 242) and the Emergency Stop Logic (Object: 0x25, Attribute: 243) will also be changed automatically.

Table 4.27 Emergency Input Function Selection

Bit	Description
0	0: Emergency stop function is disable. 1: Emergency stop function is enable.
1	0: Emergency stop Input is Active Low. 1: Emergency stop Input is Active High.

Emergency Stop Action (Object: 0x64, Attribute: 42; Pn81C)

Use the Emergency Stop Action to set the operation of the emergency stop.

If this parameter is changed, the Emergency Stop Action (Object: 0x25, Attribute: 241) will also be changed automatically.

Table 4.28 Emergency Stop Action

Setting	Description
0	Hard Stop and Servo OFF
1 to 255	Reserved



4.3.4 Speed, Acceleration, and Deceleration Parameters

■ Acceleration and Deceleration Patterns

The following eight acceleration and deceleration patterns are possible by combining acceleration/deceleration types and filters.

Table 4.29 Acceleration/Deceleration

		Acceleration/Deceleration Type (Pn826 or Pn836)			
		0: None	1: Single-step Linear	2: Double-step Linear	3: Asymmetric
Filter Selection (Pn829)	0: None	No acceleration and deceleration	1. Single-step Linear Accel/Decel Constant Accel/Decel* ¹	2. Double-step Linear Accel/Decel Constant Accel/Decel* ¹	3. Asymmetric Linear Accel/Decel Constant Accel/Decel* ¹
	1: Exponent	4. Exponential Accel/Decel Constant Accel/Decel time* ²	---	---	---
	2: Exponent with Bias	5. Exponential Accel/Decel with Bias Constant Accel/Decel time* ²	---	---	---
	3: Moving Average	6. Single-step Linear Accel/Decel Constant Accel/Decel time* ²	7. S-curve Accel/Decel Constant Accel/Decel* ¹	---	8. Asymmetric S-curve Accel/Decel Constant Accel/Decel* ¹

* 1. With Constant Accel/Decel, the time required for acceleration and deceleration changes with the feed speed changes.

* 2. With Constant Accel/Decel time, the time required for acceleration and deceleration does not change even if the feed speed changes.

Note: Combinations other than those given above may result in incorrect acceleration and deceleration.

Single-step Linear Acceleration/Deceleration with Constant Acceleration/Deceleration

Table 4.30 Related Parameters

Object	Attribute	Pn□□□	Name
0x64	56	Pn826	Acceleration/Deceleration Type (= 1)
	58	Pn829	Filter Selection (= 0)
	51	Pn821	Feed Speed
	52	Pn822	Acceleration/Deceleration Time Constant
	73	Pn843	Maximum Feed Speed

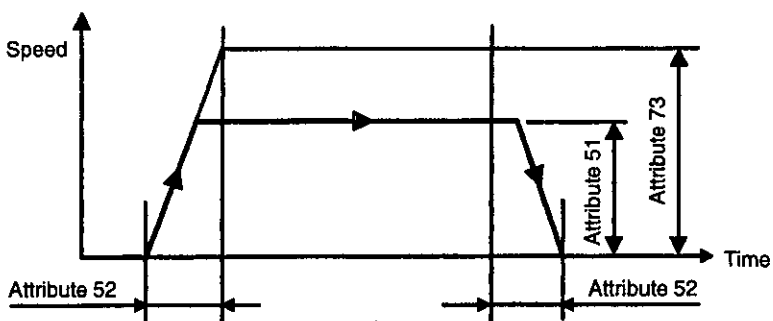

Figure 4.6 Single-step Linear Acceleration/Deceleration

Double-step Linear Acceleration/Deceleration with Constant Acceleration/Deceleration

Table 4.31 Related Parameters

Object	Attribute	Pn□□□	Name
0x64	56	Pn826	Acceleration/Deceleration Type (= 2)
	58	Pn829	Filter Selection (= 0)
	51	Pn821	Feed Speed
	52	Pn822	Acceleration/Deceleration Time Constant
	54	Pn824	Switch speed for second Accel/Decel
	55	Pn825	Second Accel/Decel Time Constant
	73	Pn843	Maximum Feed Speed

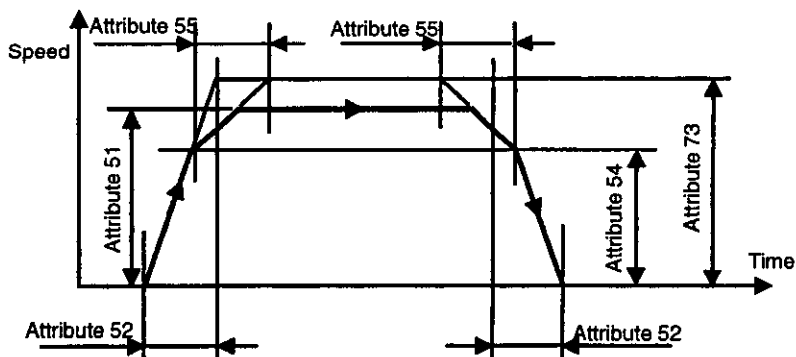

Figure 4.7 Double-step Linear Acceleration/Deceleration

Asymmetric Linear Acceleration/Deceleration with Constant Acceleration/Deceleration

Table 4.32 Related Parameters

Object	Attribute	Pn□□□	Name
0x64	56	Pn826	Profile Type (= 3)
	58	Pn829	Filter (= 0)
	51	Pn821	Feed Speed
	52	Pn822	Acceleration/Deceleration Time Constant
	53	Pn823	Deceleration Time Constant for Asymmetric
	73	Pn843	Maximum Feed Speed

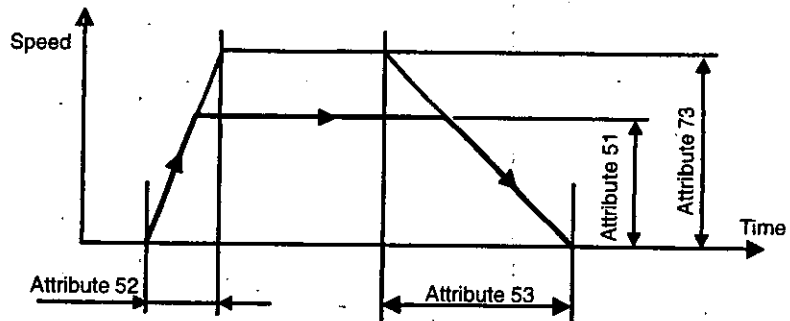

Figure 4.8 Asymmetric Linear Acceleration/Deceleration

Exponential Acceleration/Deceleration with Constant Acceleration/Deceleration

Table 4.33 Related Parameters

Object	Attribute	Pn□□□	Name
0x64	56	Pn826	Profile Type (= 0)
	58	Pn829	Filter (= 1)
	51	Pn821	Feed Speed
	70	Pn840	Exponential Time Constant

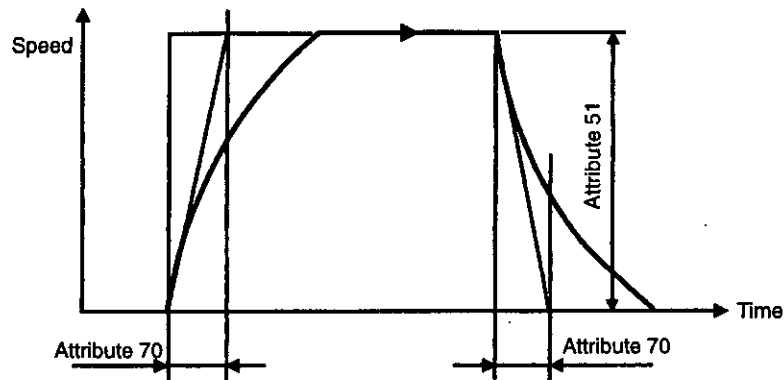

Figure 4.9 Exponential Acceleration/Deceleration

Exponential Acceleration/Deceleration with Bias with Constant Acceleration/Deceleration Time

Table 4.34 Related Parameters

Object	Attribute	Pn□□□	Name
0x64	56	Pn826	Profile Type (= 0)
	58	Pn829	Filter (= 2)
	51	Pn821	Feed Speed
	70	Pn840	Exponential Time Constant
	71	Pn841	Bias Speed

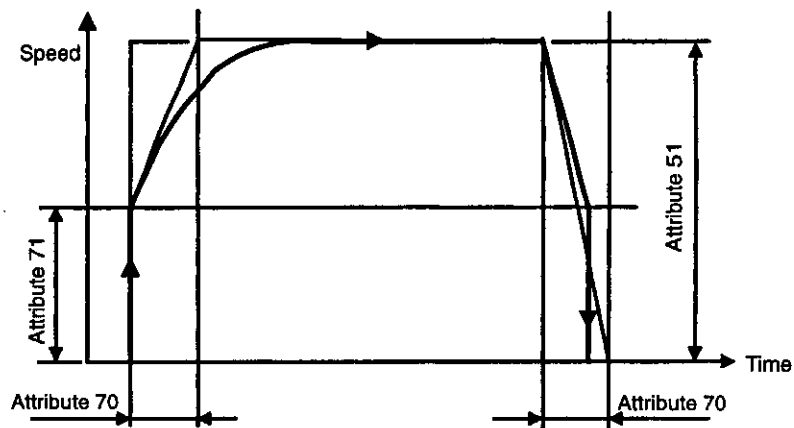

Figure 4.10 Exponential Acceleration/Deceleration with Bias

Single-step Linear Acceleration/Deceleration with Constant Acceleration/Deceleration Time

Table 4.35 Related Parameters

Object	Attribute	Pn□□□	Name
0x64	56	Pn826	Profile Type (= 0)
	58	Pn829	Filter (= 3)
	51	Pn821	Feed Speed
	72	Pn842	Moving Average Time Constant

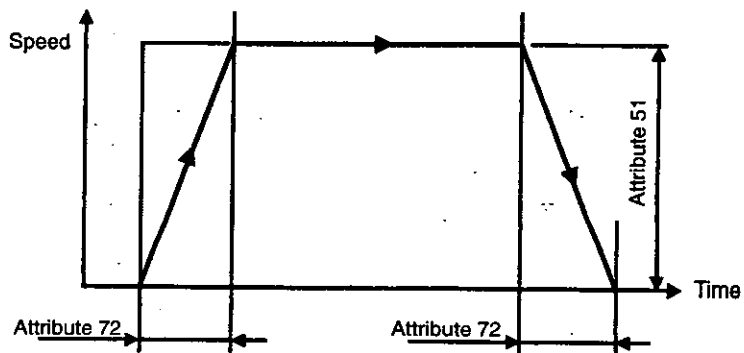

Figure 4.11 Single-step Linear Acceleration/Deceleration

S-curve Acceleration/Deceleration with Constant Acceleration/Deceleration

Table 4.36 Related Parameters

Object	Attribute	Pn□□□	Name
0x64	56	Pn826	Profile Type (= 1)
	58	Pn829	Filter (= 3)
	51	Pn821	Feed Speed
	52	Pn822	Acceleration/Deceleration Time Constant
	72	Pn842	Moving Average Time Constant
	73	Pn843	Maximum Feed Speed

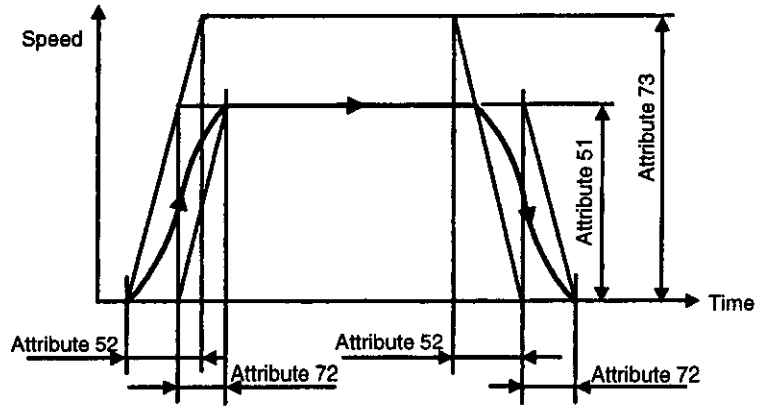

Figure 4.12 S-curve Acceleration/Deceleration

Asymmetric S-curve Acceleration/Deceleration with Constant Acceleration/Deceleration

Table 4.37 Related Parameters

Object	Attribute	Pn□□□	Name
0x64	56	Pn826	Profile Type
	58	Pn829	Filter
	51	Pn821	Feed Speed (mm/min)
	52	Pn822	Acceleration/Deceleration Time Constant
	53	Pn823	Deceleration Time Constant for Asymmetric
	72	Pn842	Moving Average Time Constant
	73	Pn843	Maximum Feed Speed

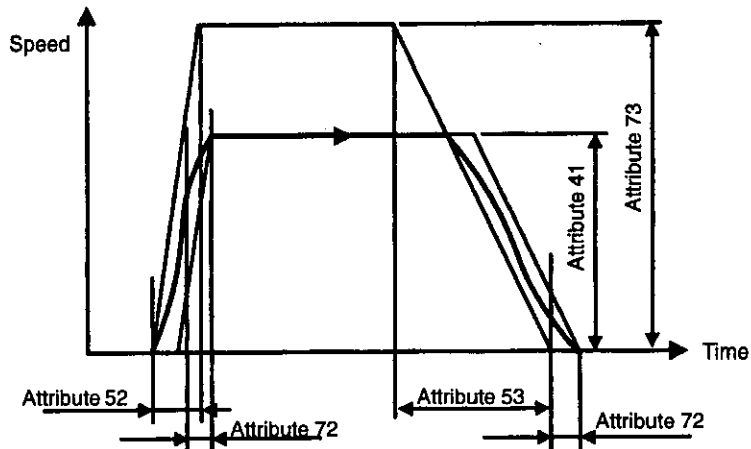

Figure 4.13 Asymmetric S-curve Acceleration/Deceleration



The details of speed, acceleration, and deceleration parameters are given below.

■ Parameter Details (Object 0x25)

Target Speed (Object: 0x25, Attribute: 7)

Use the Target Speed to set the feed speed of the positioning and the continuous rotary operation. The setting unit is step/s.

If this parameter is changed, the Feed Speed for Positioning (Object: 0x64, Attribute: 51; Pn821) will also be changed automatically.

The conversion is performed using the following formula.

- Target Speed (step/s) = Feed Speed (1,000 step/min) × 1,000 ÷ 60

Acceleration (Object: 0x25, Attribute: 8)

Use the Acceleration to set the acceleration of the positioning, the continuous rotary operation, and the homing. The setting unit is step/s².

If this parameter is changed, the Acceleration/Deceleration Time Constant for Positioning (Object: 0x64, Attribute: 52; Pn822) will also be changed automatically.

The conversion is performed using the following formula.

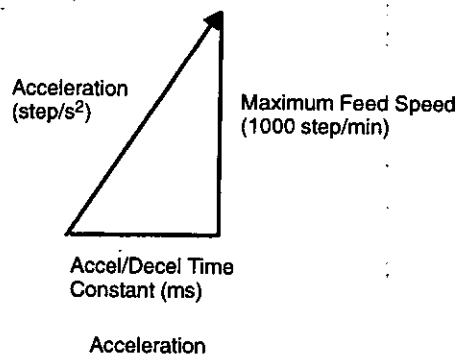

- Acceleration (step/s²) = Maximum Feed Speed (1000 step/min) × 10⁶ ÷ {Accel/Decel Time Constant (ms) × 60}

Deceleration (Object: 0x25, Attribute: 9)

Use the Deceleration to set the deceleration of the positioning, the continuous rotary operation, and the homing. The setting unit is step/s². This parameter is enabled only when the Acceleration/Deceleration Type for Positioning (Object: 0x64, Attribute: 56; Pn826) is set to the initial value, 3 (Asymmetrical linear acceleration and deceleration).

If this parameter is changed, the Deceleration Time Constant for Asymmetric (Object: 0x64, Attribute: 53; Pn823) will also be changed automatically.

The conversion is performed using the following formula.

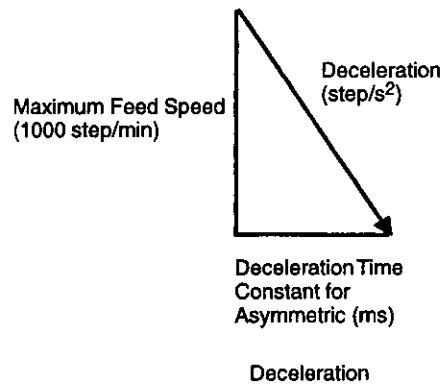

- $\text{Deceleration (step/s}^2\text{)} = \text{Maximum Feed Speed (1,000 step/min)} \times 10^6 \div \{\text{Deceleration Time Constant for Asymmetric (ms)} \times 60\}$

Profile Type (Object: 0x25, Attribute: 18)

Use the Profile Type to set the acceleration and deceleration type for positioning and continuous rotation operation.

If this parameter is changed, the Acceleration/Deceleration Type for Positioning (Object: 0x64, Attribute:56; Pn826), the Filter Selection (Object: 0x64, Attribute: 58; Pn829), and the Acceleration/Deceleration Type for JOG (Object: 0x64, Attribute: 65; Pn836) will also be changed automatically.

Table 4.38 The Relationship between Profile Type, Pn826, Pn836, and Pn829

Setting	Acceleration/Deceleration	Pn826 and Pn836	Pn829
0	Asymmetric Linear Accel/Decel Constant Accel/Decel* ¹	3	0
1	Asymmetric S-curve Accel/Decel Constant Accel/Decel* ¹	3	3
2	Exponential Accel/Decel Constant Accel/Decel time* ²	0	1
240	Single-step Linear Accel/Decel Constant Accel/Decel* ¹	1	0
241	Double-step Linear Accel/Decel Constant Accel/Decel* ¹	2	0
242	Exponential Accel/Decel with Bias Constant Accel/Decel time* ²	0	2
243	Single-step Linear Accel/Decel Constant Accel/Decel time* ²	0	3
244	S-curve Accel/Decel Constant Accel/Decel* ¹	1	3
245	No Acceleration and Deceleration	0	0

- * 1. With Constant Accel/Decel, the time required for acceleration and deceleration changes with the feed speed changes.
- * 2. With Constant Accel/Decel time, the time required for acceleration and deceleration does not change even if the feed speed changes.

Profile Gain (Object: 0x25, Attribute: 19)

Use the Profile Gain to set the gain for the S-curve profile. The setting unit is ms. Make setting between 4 and 1000.

If this parameter is changed, the Time Constant for Moving Average (Object: 0x64, Attribute: 72; Pn842) will also be changed automatically.

■ **Parameter Details (Object 0x64)**

Feed Speed for Positioning (Object: 0x64, Attribute: 51; Pn821)

Use the Feed Speed for Positioning to set the feed speed of the positioning. The setting unit is 1,000 step/min.

If this parameter is changed, the Target Speed (Object: 0x25, Attribute: 7) will also be changed automatically.

Acceleration/Deceleration Time Constant for Positioning (Object: 0x64, Attribute: 52; Pn822)

Use the Acceleration/Deceleration Time Constant for Positioning to set the time constant for acceleration and deceleration for the positioning. The setting unit is ms.

If this parameter is changed, Acceleration (Object: 0x25, Attribute: 8) will also be changed automatically.

Deceleration Time Constant for Asymmetric (Object: 0x64, Attribute: 53; Pn823)

Use the Deceleration Time Constant for Asymmetric to set the time constant for deceleration when using asymmetrical linear acceleration and deceleration. The setting unit is ms.

This parameter is enabled only when the Acceleration/Deceleration Type for Positioning (Object: 0x64, Attribute: 56; Pn826) is set to the initial value, 3 (Asymmetrical linear acceleration and deceleration).

Switch Speed of Second Acceleration/Deceleration (Object: 0x64, Attribute: 54; Pn824)

Use the Switch Speed of Second Acceleration/Deceleration to set the switching speed to acceleration and deceleration of the second step when using double-step linear acceleration and deceleration. The setting unit is 1,000 step/s.

This parameter is enabled only when the Acceleration/Deceleration Type for Positioning (Object: 0x64, Attribute: 56; Pn826) is set to 2 (Double-step linear acceleration and deceleration).

Time Constant of Second Acceleration/Deceleration (Object: 0x64, Attribute: 5; Pn825)

Use the Time Constant of Second Acceleration/Deceleration to set the time constant for acceleration and deceleration of the second step when using double-step linear acceleration and deceleration. The setting unit is ms.

This parameter is enabled only when the Acceleration/Deceleration Type for Positioning (Object: 0x64, Attribute: 56; Pn826) is set to 2 (Double-step linear acceleration and deceleration).

Acceleration/Deceleration Type for Positioning (Object: 0x64, Attribute: 56; Pn826)

Use the Acceleration/Deceleration Type for Positioning to set the type of acceleration and deceleration for the positioning.

You can set eight different acceleration and deceleration patterns using different combinations of Acceleration/Deceleration Type for Positioning and Filter Selection (Object: 0x64, Attribute: 58; Pn829).

Table 4.39 Acceleration/Deceleration Type for Positioning

Setting	Description
0	None
1	Single Step Linear
2	Double Step Linear
3	Asymmetric

Filter Selection (Object: 0x64, Attribute: 58; Pn829)

Use the Filter Selection to set the acceleration and deceleration filter type. This parameter is used in common by the positioning, continuous rotary operation, and the homing.

Table 4.40 Filter Selection

Setting	Description
0	None
1	Exponential
2	Exponential with Bias
3	Moving Average

Feed Speed for JOG (Object: 0x64, Attribute: 60; Pn831)

Use the Feed Speed for JOG to set the feed speed when using the continuous rotary operation. The setting unit is 1,000 step/min.

Acceleration/Deceleration Time Constant for JOG (Object: 0x64, Attribute: 61; Pn832)

Use the Acceleration/Deceleration Time Constant for JOG to set the acceleration and deceleration time constant when using the continuous rotary operation. The setting unit is ms.

Deceleration Time Constant for JOG (Object: 0x64, Attribute: 62; Pn833)

Use the Deceleration Time Constant for JOG to set the deceleration time constant when using asymmetrical acceleration and deceleration with the continuous rotary operation. The setting unit is ms.

This parameter is enabled only when the Acceleration/Deceleration Type for JOG (Object: 0x64, Attribute: 65; Pn836) is set to the initial value, 3 (Asymmetrical linear acceleration and deceleration).

Switch Speed for JOG (Object: 0x64, Attribute: 63; Pn834)

Use the Switch Speed for JOG to set the switching speed to double-step acceleration and deceleration when using double-step linear acceleration and deceleration with the continuous rotary operation. The setting unit is 1,000 step/min.

This parameter is enabled only when the Acceleration/Deceleration Type for JOG (Object: 0x64, Attribute: 65; Pn836) is set to 2 (Double-step linear acceleration and deceleration).

Time Constant of Second Acceleration/Deceleration for JOG (Object: 0x64, Attribute: 64; Pn835)

Use the Time Constant of Second Acceleration/Deceleration for JOG to set the time constant for double-step acceleration and deceleration when using double-step linear acceleration and deceleration with the continuous rotary operation. The setting unit is ms.

This parameter is enabled only when the Acceleration/Deceleration Type for JOG (Object: 0x64, Attribute: 65; Pn836) is set to 2 (Double-step linear acceleration and deceleration).

Acceleration/Deceleration Type for JOG (Object: 0x64, Attribute: 65; Pn836)

Use the Acceleration/Deceleration Type for JOG to set the acceleration and deceleration type when using continuous rotary operation.

You can set eight different acceleration and deceleration patterns using different combinations of Acceleration/Deceleration Type for JOG and Filter Selection (Object: 0x64, Attribute: 58; Pn829).

Table 4.41 Acceleration/Deceleration Type for JOG

Setting	Description
0	None
1	Single Step Linear
2	Double Step Linear
3	Asymmetric

Time Constant for Exponential Curve (Object: 0x64, Attribute: 70; Pn840)

Use the Time Constant for Exponential Curve to set the time constant when using exponential acceleration and deceleration. This parameter is used in common by the positioning and the continuous rotary operation. The setting unit is ms.

Bias Speed (Object: 0x64, Attribute: 71; Pn841)

Use the Bias Speed to set the bias speed of the exponential acceleration and deceleration. The setting unit is 1,000 step/min.

Time Constant of Moving Average (Object: 0x64, Attribute: 72; Pn842)

Use the Time Constant of Moving Average to set the time constant of the average travel speed of the acceleration and deceleration. This parameter is used in common by the positioning and the continuous rotary operation. The setting unit is ms.

Maximum Feed Speed (Object: 0x64, Attribute: 73; Pn843)

Use the Maximum Feed Speed to set the maximum feed speed of the positioning, the continuous rotary operation, and the homing. The acceleration and deceleration data is calculated from this data and the time constants. The setting unit is 1,000 step/min.

4.3.5 Positioning Parameters

The details of parameters relating to positioning are given below.

■ **Parameter Details (Object 0x25)**

Kp (Object: 0x25, Attribute: 30)

Use the Kp to set the position loop gain of the SGDh. The setting unit is 1/s.

If this parameter is changed, the Position Loop Gain (Object: 0x66, Attribute: 52; Pn102) will also be changed automatically.

Position Deadband (Object: 0x25, Attribute: 38)

Use the Position Deadband to set the positioning completed range for setting the On-Target Position in a response message. The setting unit is step.

If this parameter is changed, the Positioning Deadband (Object: 0x64, Attribute: 90; Pn850) will also be changed automatically.

Max Dynamic Following Error (Object: 0x25, Attribute: 45)

Use the Max Dynamic Following Error to set the error pulse level of the position loop in the SGDH. If the error pulses of position-loop exceed this value, the Following Error Fault (Object: 0x25, Attribute: 47) will be set. The setting unit is step.

If this parameter is changed, the Overflow Level (Object: 0x66, Attribute: 165; Pn505) will also be changed automatically.

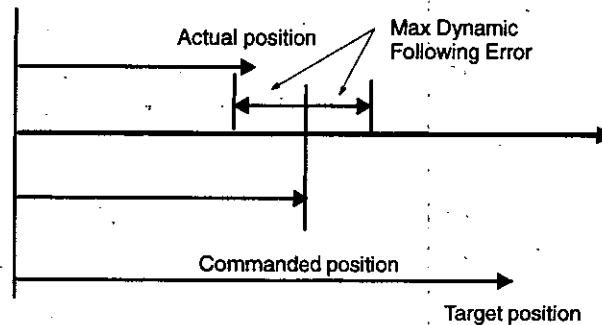

■ **Parameter Details (Object 0x65)**

Positioning Deadband (Object: 0x64, Attribute: 90; Pn850)

Use the Positioning Deadband to set the positioning completed range, i.e., to determine if the axis is On-Target Position. The setting unit is step. When the Positioning Deadband is set to 0, no On-Target Position check will be performed.

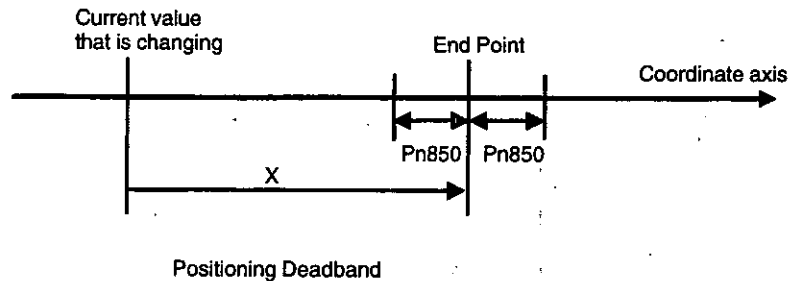

When the following condition is satisfied in the above Figure, the axis is viewed as being On-Target Position.

- $X = (\text{End point} - \text{Current value that is changing}) \leq P$

Positioning Timeout (Object: 0x64, Attribute: 91; Pn851)

Use the Positioning Timeout to set the time for performing On-Target Position check. The setting unit is ms. If, after the move command distribution has been completed, the positioning completed range is not entered within the time set, an A9A Positioning Completion Error warning will be sent.

If this parameter is set to 0, the check time becomes infinite.

5

DeviceNet Communications

This chapter explains commands to and editing parameters in an NS310 Unit using DeviceNet communications.

5.1 Specifications and Configuration	5 - 3
5.1.1 Specifications	5 - 3
5.1.2 Control Configuration	5 - 3
5.2 DeviceNet Communications	
Setting Switches	5 - 4
5.2.1 Rotary Switch Settings for Setting Node Address	5 - 4
5.2.2 Rotary Switch Settings for Setting Baud Rate ...	5 - 5
5.2.3 LED Indicators	5 - 5
5.3 Command/Response Format	5 - 7
5.3.1 Command Format	5 - 7
5.3.2 Command Data Specifications	5 - 9
5.3.3 Response Format	5 - 11
5.4 Commands from the Host Controller	5 - 15
5.4.1 Positioning	5 - 15
5.4.2 Continuous Rotary Operation	5 - 16
5.4.3 Homing	5 - 18
5.4.4 Hard Stop Operation	5 - 20
5.4.5 Deceleration and Stop Operation	5 - 21
5.4.6 Emergency Stop Operation	5 - 21
5.4.7 Hardware Limit Operation	5 - 22
5.4.8 Software Limit Operation	5 - 23
5.5 Program Function	5 - 24
5.5.1 Outline	5 - 24
5.5.2 Command Blocks	5 - 26
5.5.3 Command Block Links	5 - 32



5.6 Changing Parameters and	
Command Blocks	5 - 34
5.6.1 DeviceNet Data Management	5 - 34
5.6.2 Editing Parameters	5 - 35
5.6.3 Editing Command Blocks	5 - 37
5.6.4 Organizing Data	5 - 37

5.1 Specifications and Configuration

5.1.1 Specifications

Refer to *DeviceNet Specification Release 2.0* for details not specified in this manual.

5.1.2 Control Configuration

An outline of the control configuration is given below. A maximum of 63 NS310 Units or other slave devices can be connected to one DeviceNet Master.

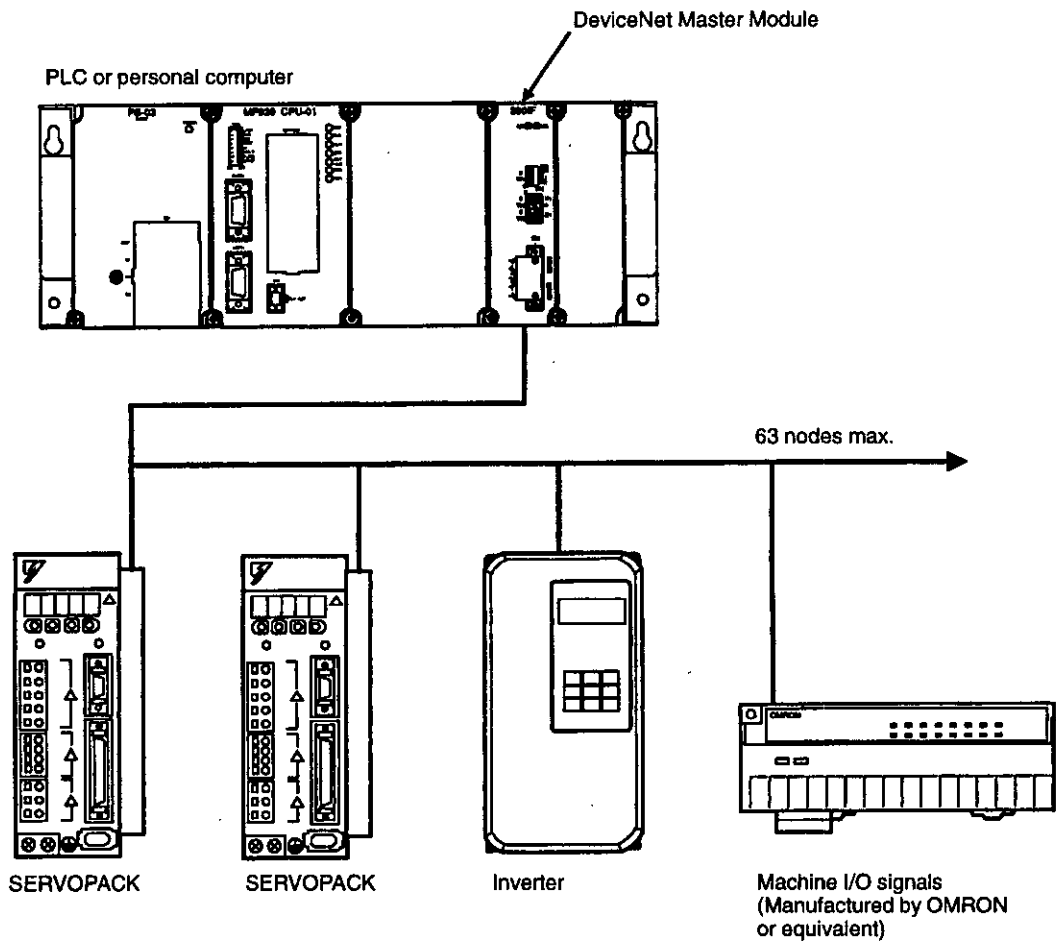

5.2 DeviceNet Communications Setting Switches

This section explains the switch settings required for DeviceNet communications.

5.2.1 Rotary Switch Settings for Setting Node Address

Use the rotary switches (x1, x10) to set the DeviceNet node address. After making the settings, cycle the communications power to enable the settings.

The node address can be set between 0 and 63. If you make a setting outside this range, a setting error will occur.

Select the node address of the NS310 Unit using the switch settings as shown in the following table.

× 10	× 1	Node Address	× 10	× 1	Node Address	× 10	× 1	Node Address
0	0	0	3	4	34	6	8	Setting error
0	1	1	3	5	35	6	9	Setting error
0	2	2	3	6	36	7	0	Setting error
0	3	3	3	7	37	7	1	Setting error
0	4	4	3	8	38	7	2	Setting error
0	5	5	3	9	39	7	3	Setting error
0	6	6	4	0	40	7	4	Setting error
0	7	7	4	1	41	7	5	Setting error
0	8	8	4	2	42	7	6	Setting error
0	9	9	4	3	43	7	7	Setting error
1	0	10	4	4	44	7	8	Setting error
1	1	11	4	5	45	7	9	Setting error
1	2	12	4	6	46	8	0	Setting error
1	3	13	4	7	47	8	1	Setting error
1	4	14	4	8	48	8	2	Setting error
1	5	15	4	9	49	8	3	Setting error
1	6	16	5	0	50	8	4	Setting error
1	7	17	5	1	51	8	5	Setting error
1	8	18	5	2	52	8	6	Setting error
1	9	19	5	3	53	8	7	Setting error
2	0	20	5	4	54	8	8	Setting error
2	1	21	5	5	55	8	9	Setting error
2	2	22	5	6	56	9	0	Setting error
2	3	23	5	7	57	9	1	Setting error
2	4	24	5	8	58	9	2	Setting error
2	5	25	5	9	59	9	3	Setting error
2	6	26	6	0	60	9	4	Setting error
2	7	27	6	1	61	9	5	Setting error
2	8	28	6	2	62	9	6	Setting error
2	9	29	6	3	63	9	7	Setting error
3	0	30	6	4	Setting error	9	8	Setting error
3	1	31	6	5	Setting error	9	9	Setting error
3	2	32	6	6	Setting error	---	---	---
3	3	33	6	7	Setting error	---	---	---

5.2.2 Rotary Switch Settings for Setting Baud Rate

Use the DR rotary switches to set the DeviceNet baud rate. After making the settings, cycle the communications power supply to enable the settings.

Table 5.1 DR Settings

DR	Baud Rate Setting
0	125 Kbps
1	250 Kbps
2	500 Kbps
3 to 9	A setting error will occur.

5.2.3 LED Indicators

NS310 Units are equipped with two LED indicators, the Module Status indicator to indicate the Unit status, and the Network Status indicator to indicate the DeviceNet communications status.

The LED indicator specifications conform to DeviceNet communications specifications.

■ Module Status (MS) Indicator

The MS indicator shows the status of the NS310 Unit.

Status	Indicator
Communications power supply is turned OFF.	Not lit.
Unit is operating normally.	Lit green.
Unit is warming up.	Flashes green.
Minor Unit failure.	Flashes red.
Major Unit failure.	Lit red.
Unit is performing self-diagnosis.	Red and green flash alternately.

Refer to the alarm codes in *Appendix C* for details of the malfunction if the the Module Status indicator is either flashing red or lit red.

■ Network Status (NS) Indicator

The NS indicator shows the status of DeviceNet communications.

Status	Indicator
Power supply is turned OFF or Unit is not online.	Not lit.
Unit is online, but is not connected to the Master device.	Flashes green.

5.2.3 LED Indicators

Status	Indicator
Unit is online, and is connected to the Master device.	Lit green.
Connection to the Master device has timed out.	Flashes red.
A fatal error has occurred in DeviceNet communications.	Lit red.

5.3 Command/Response Format

This section explains command/response messages.

5.3.1 Command Format

This section explains command messages sent to the NS310 Unit from the Master device.

The following table shows the data format of command messages sent to the NS310 Unit from the Master device.

Command messages consist of 8 bytes. Bytes 0 to 3 have the same format for all commands, and byte 0 holds bit unit commands. Bytes 4 to 7 store data that depend on the command code in byte 2.

Table 5.2 Command Message Format

Byte	Bit 7	Bit 6	Bit 5	Bit 4	Bit 3	Bit 2	Bit 1	Bit 0
0	Enable	Valid Data	Hard Stop	Smooth Stop	Direction (V mode)	Absolute/ Incremental	Start Block	Start Trajectory
1	Block Number							
2	Axis Instance (001)			Command Code				
3	Axis Instance (001)			Response Code				
4	Data Low Byte							
5	Data Low Middle Byte							
6	Data High Middle Byte							
7	Data High Byte							

■ Start Trajectory

Use the Start Trajectory command to start a move operation. For the command codes given below, start the move operation by changing the command bit from 0 to 1.

- Positioning command (Code = 0x01)
- Continuous Rotor Speed command (Code = 0x11)
- Homing command (Code = 0x12)
- Alarm Clear command (Code = 0x1E)

The NS310 Unit detects the command using the rising edge from 0 to 1, so the operation will continue even if the command bit is reset during travel.

To stop the move operation before it have been completed, set the Smooth Stop command bit or Hard Stop command bit to 1.

■ Start Block

Use the Start Block command to execute the command block stored in the NS310 Unit. By setting this command bit to 1, you can execute commands according to the command blocks that have been registered in advance.

Refer to 5.5.2 *Command Blocks* for command block details.

■ Absolute/Incremental

Use the Absolute/Incremental command to specify whether the value of the target position data stored in bytes 4 to 7 is the absolute position or incremental. This data is enabled when the Start Trajectory command is set to 1.

0: Absolute position

1: Incremental position

■ Direction

Use the Direction command to specify the rotor direction as viewed from the motor side of the shaft when the rotary is running continuously. This command is only enabled when the command code (Command Code) is set to Continuous Rotary Operation (Code: 0x11).

0: Reverse direction, negative direction, counterclockwise

1: Forward direction, positive direction, clockwise

■ Smooth Stop

Set this command bit to 1 to stop travel at the current deceleration setting. The Valid Data does not affect this command bit.

■ Hard Stop

Set this command bit to 1 to stop movement using the maximum deceleration speed. The Valid Data does not affect this command.

■ Valid Data

The NS310 Unit refreshes the command code, response code, and command data it has received only when the Valid Data command has been set. Commands in byte 0 (Enable, Smooth Stop, or Hard Stop) are refreshed regularly regardless of the Valid Data command status.

0: Data disabled

1: Data enabled

When the Valid Data in a command message is set to 0, the Command Error in the response message will be cleared.

■ Enable

The Enable command controls the servo ON and OFF. The status of this command bit is constantly effective (i.e., rising edge detection is not performed) and it must be set to 1 whenever the servo is to be ON.

0: Servo OFF

1: Servo ON

■ Block Number

Specify the block number from which the command blocks start.

■ Axis Instance

Set the axis number. Always set the axis instance to 1, or a command error will occur.

■ Command Code

The command code defines the command data in bytes 4 to 7.

Command Code	Definition	Data Type
0x00	NOP	---
0x01	Target position	DINT (4 bytes)
0x02	Target speed	DINT (4 bytes)
0x03	Acceleration	DINT (4 bytes)
0x04	Deceleration	DINT (4 bytes)
0x05 to 0x10	Reserved	---
0x11	Continuous rotor speed	DINT (4 bytes)
0x12	Homing type	USINT (1 byte)
0x13 to 0x1D	Reserved	---
0x1E	Alarm clear	BOOL (1 byte)
0x1F	Reserved	---

■ Response Code

The response code specifies the current position, current speed, and other data included in the response message. Refer to 5.3.3 *Response Format*.

■ Command Data

Set the data defined for the command code.

5.3.2 Command Data Specifications

The command data specifications are given below.

■ NOP (Code = 0x00)

This code has no meaning.

■ Target Position (Code = 0x01)

Use the Target Position command to set the target position. The setting unit is step. This setting data is enabled when the Valid Data Flag is set to 1. The positioning starts when the Start Trajectory command is set to 1 after the Target Position setting has been made (both are possible simultaneously).

How the Target Position is handled depends on the Absolute/Incremental setting, as shown below.

1. Absolute/Incremental = 0 (Absolute position)

If the current position is +200 and the command data is +300, the target position will be +300.

2. Absolute/Incremental = 1 (Relative position)

If the current position is +200 and the command data is +300, the target position will be +500.

■ Target Speed (Code = 0x02)

Use the Target Speed command to set the target speed of the positioning. The setting unit is step/s. This setting data is enabled when the Valid Data Flag is set to 1. Make sure this data always has a positive value.

■ Acceleration (Code = 0x03)

Use the Acceleration command to set the acceleration of the positioning, continuous rotary operation, and homing. The setting unit is step/s^2 . This setting data is enabled when the Valid Data Flag is set to 1. Make sure this data always has a positive value.

■ Deceleration (Code = 0x04)

Use the Deceleration command to set the deceleration of the positioning, continuous rotary operation, and homing. The setting unit is step/s^2 . This setting data is enabled when the Valid Data Flag is set to 1. Make sure this data always has a positive value.

■ Continuous Rotor Speed (Code = 0x11)

Use the Continuous Rotor Speed command to set the target speed of the continuous rotary operation. This setting data is enabled when the Valid Data Flag is set to 1. Make sure this data always has a positive value. The direction of rotation is determined by the DIR signal.

■ Homing Type (Code = 0x12)

Use the Homing Type command to set the homing type. This setting data is enabled when the Valid Data Flag is set to 1. Refer to 5.4.3 *Homing* for the homing types.

Byte	Bit 7	Bit 6	Bit 5	Bit 4	Bit 3	Bit 2	Bit 1	Bit 0
4	Homing Type							
5	0x00							
6	0x00							
7	0x00							

■ Alarm Clear (Code = 0x1E)

Use the Alarm Clear command to clear the NS310 Unit and SGDH alarms. Set the Alarm Clear bit to 1, the Valid Data Flag, and then the Start Trajectory command bit. Alarms in the NS310 Unit and SGDH will be cleared on the rising edge of the start trajectory bit.

Byte	Bit 7	Bit 6	Bit 5	Bit 4	Bit 3	Bit 2	Bit 1	Bit 0
4	0	0	0	0	0	0	0	Alarm Clear
5	0x00							
6	0x00							
7	0x00							

5.3.3 Response Format

This section explains the response messages from the NS310 Unit to the Master device.

The following table shows the data format of response messages sent from the NS310 Unit to the Master device.

Response messages consist of 8 bytes. Bytes 0 to 3 have the same format for all commands sent from the Master device. Byte 0 and byte 2 show the Unit status using bits. Bytes 4 to 7 store data that depend on the response code in byte 3.

Table 5.3 Response Format

Byte	Bit 7	Bit 6	Bit 5	Bit 4	Bit 3	Bit 2	Bit 1	Bit 0
0	Enable State	Valid Data	Home Flag	Emergency Stop Input	Alarm	On Target Position	Block In Execution	Trajectory In Progress
1	Executing Block Number							
2	Command Error	Block Fault	Trajectory Start Echo	Negative Software Limit	Positive Software Limit	CCW Hardware Limit	CW Hardware Limit	Servo Ready
3	Axis Instance (001)			Response Code				
4	Data Low Byte							
5	Data Low Middle Byte							

Byte	Bit 7	Bit 6	Bit 5	Bit 4	Bit 3	Bit 2	Bit 1	Bit 0
6	Data High Middle Byte							
7	Data High Byte							

■ Trajectory In Progress

This bit is set to 1 during a positioning, continuous rotary operation, or homing. When the Valid Data Flag and Start Trajectory command bits are received from the Master device, operation is started and this bit is set to 1. The bit is set to 0 when the operation has been completed.

■ Block In Execution

This bit is set to 1 when executing block commands due to a Start Block command being sent. It is set to 0 when the block commands have been completed or a block error (block fault) occurs.

■ On Target Position

This bit is set to 1 when the current position is within the Position Deadband. The Position Deadband depends on the setting of the Position Deadband (Object: 0x25, Attribute: 38). Refer to *Chapter 4 Parameter Settings* for details.

■ Alarm

This bit is set to 1 if an alarm occurs in the NS310 Unit or SGD. To clear an alarm, use the Alarm Clear command.

■ Emergency Stop Input

This bit is used to monitor the emergency stop signal of the SGD.

■ Home Flag

This bit is set to 1 when the home position signal of the SGD is Active.

■ Valid Data

This bit is set to 1 after the Valid Data has been set to 1, in a command message from the Master device, to notify the Master device that the command has been received normally. When the Valid Data sent from the Master device has been set, the NS310 Unit checks the command data, and if there is no problem with the contents, the Valid Data bit is set to 1 in the response message. If there is an error in the command data, the Command Error is set to 1, and the Valid Data is also set to 1 at the same time.

■ Enable State

This bit is set to 1 when the SGD servo is ON. If the SGD servo is OFF, the NS310 Unit will ignore a Start Trajectory command even if one is received. Consequently, be sure that this bit is set to 1 before sending a Start Trajectory command.

■ Servo Ready

This bit is set to 1 when the SGDH servo can be turned ON.

■ CW Hardware Limit

This bit is set to 1 when the current position reaches the hardware limit in the clockwise (CW) direction.

■ CCW Hardware Limit

This bit is set to 1 when the current position reaches the hardware limit in the counter-clockwise (CCW) direction.

■ Positive Software Limit

This bit is set to 1 when the positive software limit is exceeded. Set the positive software limit position using the Positive Software Limit Position (Object: 0x25, Attribute: 54).

■ Negative Software Limit

This bit is set to 1 when the negative software limit is exceeded. Set the negative software limit position using the Negative Software Limit Position (Object: 0x25, Attribute 55).

■ Trajectory Start Echo

This bit is set to 1 when a Start Trajectory command is received normally from the Master device. By checking this bit, the Master device can check if a command was received normally from the NS310 Unit.

■ Block Fault

This bit is set to 1 if an error occurs during a block operation. If an error occurs, the block operation will be stopped.

■ Command Error

This bit is set to 1 if an error occurs in the command data in a command message. To clear the command error, set the Valid Data Flag to 0 in the command message.

■ Response Code

The Response Code defines the response data in bytes 4 to 7.

Response Code	Definition	Data Type
0x00	NOP	---
0x01	Current position	DINT (4 bytes)
0x02	Command position	DINT (4 bytes)
0x03	Current speed	DINT (4 bytes)



5.3.3 Response Format

Response Code	Definition	Data Type
0x04 to 0x0F	Reserved	---
0x10	Reserved	---
0x11 to 0x1D	Reserved	---
0x1E	Alarm code	DINT (4 bytes)
0x1F	Reserved	---

5.4 Commands from the Host Controller

5.4.1 Positioning

Positioning can be performed to specified target positions.

■ Using Commands

1. To change the current attribute settings, set the motion profile attributes, such as target speed, acceleration, and deceleration.
2. Use the Absolute/Incremental bit in the command message to specify whether the target position setting is an absolute or relative position.
3. Set the Command Code (0x01) and the target position in the command message.
4. Set the Valid Data Flag to 1 in the command message, and then set the Start Trajectory command to 1. You can set both the Valid Data Flag and the Start Trajectory command to 1 at the same time.
5. When the positioning starts, the Trajectory In Progress bit in the response message is set to 1. When the reference pulses to the target position have been distributed, this bit is set to 0.

■ Example of Positioning Command Messages

In this example, the settings are as follows:

Absolute position with a target position of 128,000 steps (= 0x0001F400).

The NS310 Unit assumes that data, such as the target position, is valid when the Valid Data Flag in the command message is set to 1. Consequently, set bytes 1 to 7 first, and then set byte 0.

Byte	Bit 7	Bit 6	Bit 5	Bit 4	Bit 3	Bit 2	Bit 1	Bit 0
0	1 Enable	1 Valid Data	0 Hard Stop	0 Smooth Stop	0 Direction (V Mode)	0 Absolute/Incremental	0 Start Block	1 Start Trajectory
1	0x00							
2	001 Axis Instance			0001 Command Code				
3	001 Axis Instance			0003 Response Code				
4	0x00 Target Position Low Byte							
5	0xF4 Target Position Low Middle Byte							
6	0x01 Target Position High Middle Byte							
7	0x00 Target Position High Byte							

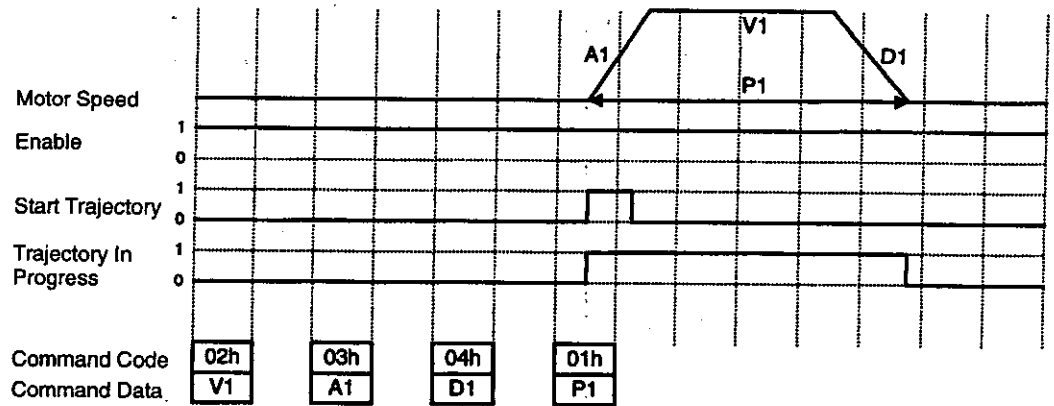

IMPORTANT

1. If an alarm occurs, the servo is OFF, or another operation command is being performed (e.g., continuous rotary operation, homing, etc.), positioning will be disabled.
2. Be sure that the Enable State bit in the response message is set to 1, and then set the Start Trajectory command bit. If you turn ON the Enable command and the Start Trajectory command at the same time, the Start Trajectory command will be ignored.

5.4.2 Continuous Rotary Operation

This command performs the continuous rotary operation at a fixed speed.

■ Using Commands

1. To change the current attribute settings, set the motion profile attributes, such as acceleration and deceleration.
2. Set the Direction in the command message.
3. Set the Command Code (0x11) and Continuous Rotation Speed in the command message.
4. Set the Valid Data Flag to 1 in the command message, and then set the Start Trajectory command to 1. You can set both the Valid Data Flag and the Start Trajectory command to 1 at the same time.
5. When the continuous rotary operation starts, the Trajectory In Progress bit in the response message is set to 1.
6. During the continuous rotary operation, changing the continuous rotation speed or rotation direction will change the speed and direction of the motor. When changing the continuous rotation speed or direction, make sure to set the Valid Data Flag and Start Trajectory command to 1.
7. To stop the continuous rotary operation, set Smooth Stop or Hard Stop attribute. You can stop the continuous rotary operation by setting the continuous rotation speed to 0.

■ Example of Continuous Rotary Operation Command Messages

In this example, the settings are as follows:

Clockwise rotation with a target speed of 8,000 reference units/s (= 0x0001F40).

The NS310 Unit assumes that data such as the continuous rotary speed is valid when the Valid Data Flag in the command message is set to 1. Consequently, set bytes 1 to 7 first, and then set byte 0.

Byte	Bit 7	Bit 6	Bit 5	Bit 4	Bit 3	Bit 2	Bit 1	Bit 0
0	1 Enable	1 Valid Data	0 Hard Stop	0 Smooth Stop	1 Direction (V Mode)	0 Absolute/ Incremental	0 Start Block	1 Start Trajectory
1	0x00							
2	001 Axis Instance			0x11 Command Code				
3	001 Axis Instance			0003 Response Code				
4	0x40 Target Speed Low Byte							
5	0x1F Target Speed Low Middle Byte							
6	0x00 Target Speed High Middle Byte							
7	0x00 Target Speed High Byte							

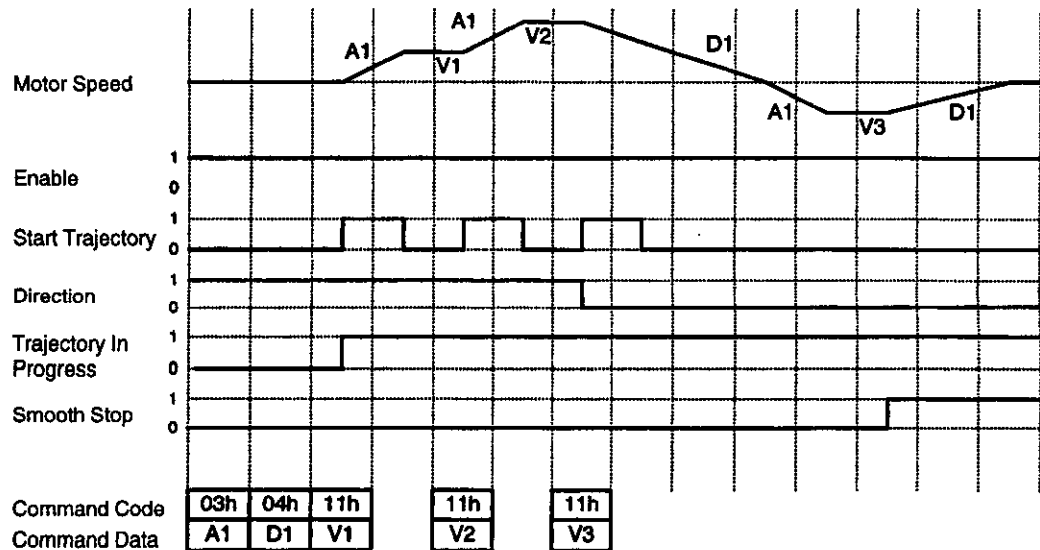

5

IMPORTANT

1. If an alarm occurs, the servo is OFF, or another operation command is being performed (e.g., positioning, homing, etc.), the continuous rotary operation will be disabled.
2. Be sure that the Enable State bit in the response message is set to 1, and then set the Start Trajectory command bit. If you turn ON the Enable command and the Start Trajectory command at the same time, the Start Trajectory command will be ignored.

5.4.3 Homing

The homing returns the axis to the machine's home position. There are three types of homing, as shown below.

■ Type 0

Type 0 performs the homing, based on the ZERO external signal (home position signal) and detection of phase C of the Encoder.

1. The axis travels at the home fast speed in the home direction that has been set.
2. When the home position signal changes, the axis will change the direction. The axis travels at the home slow speed until the home position signal changes again.
3. When the home position signal changes again, the axis will continue to travel until the first phase C was detected.
4. When phase C is detected, the axis will decelerate and return to the position where phase C was detected.

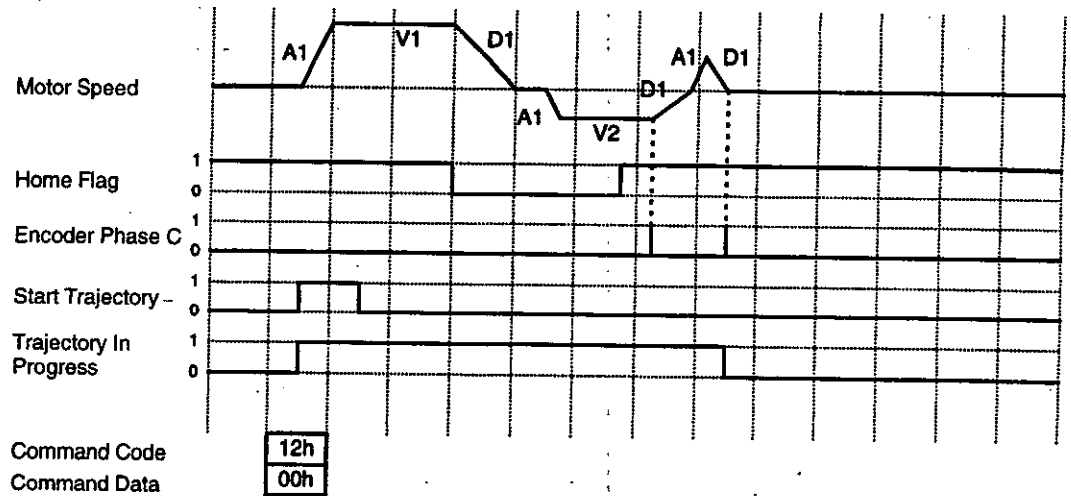

■ **Type 1**

Type 1 performs the homing, based on the ZERO external signal (home position signal) only.

1. The axis travels at the home fast speed in home direction that has been set.
2. When the home position signal changes, the axis will change direction and return to the position where the Home Position Signal changed.

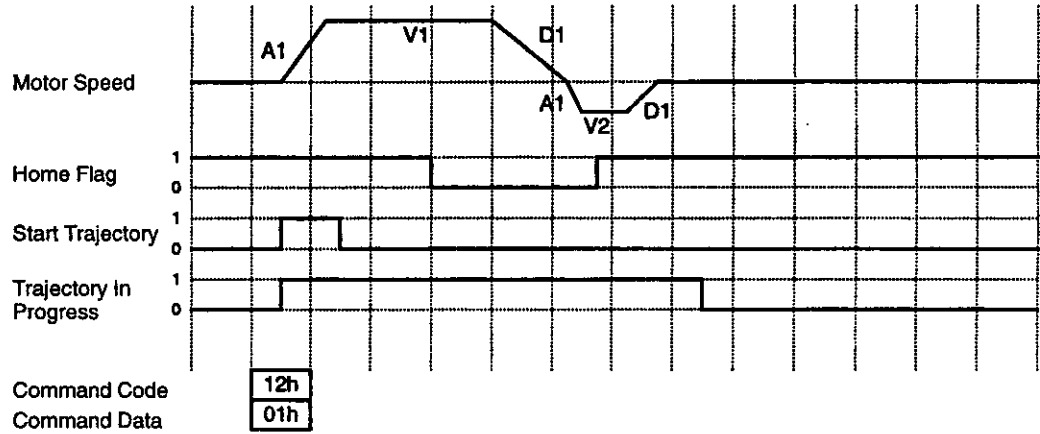

■ **Type 3**

Type 3 performs the homing, based on detecting the phase C of the Encoder only.

1. The axis travels at the home fast speed in the home direction that has been set.
2. When the first phase C is detected, the axis stops, reverses direction, and returns to the position where phase C was detected.

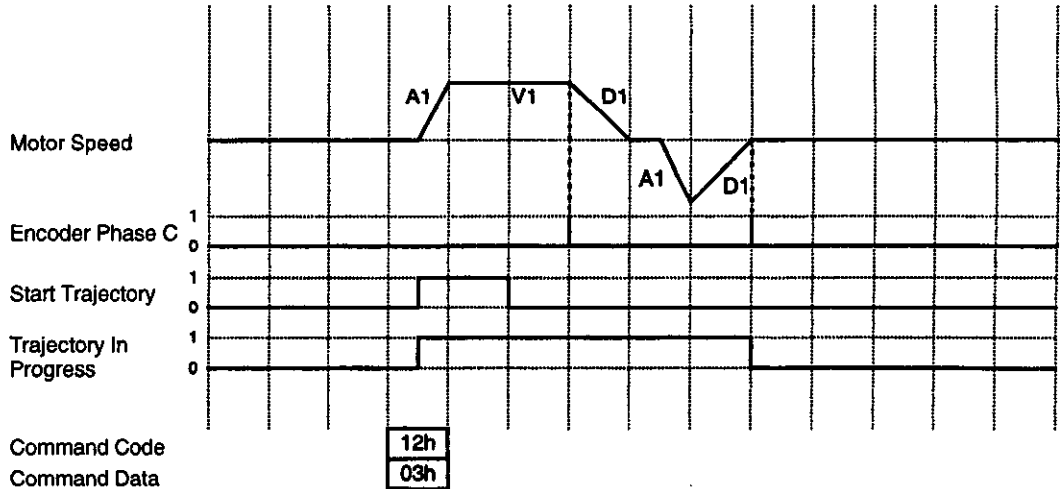

■ **Example of Homing Command Messages**

In this example, type 0 homing has been set.

The NS310 Unit assumes that data such as homing is valid when the Valid Data Flag in the command message is set to 1. Consequently, set bytes 1 to 7 first, and then set byte 0.



5.4.4 Hard Stop Operation

Byte	Bit 7	Bit 6	Bit 5	Bit 4	Bit 3	Bit 2	Bit 1	Bit 0
0	1 Enable	1 Valid Data	0 Hard Stop	0 Smooth Stop	0 Direction (V Mode)	0 Absolute/ Incremental	0 Start Block	1 Start Trajectory
1	0x00							
2	001 Axis Instance			0x12 Command Code				
3	001 Axis Instance			0001 Response Code				
4	0x00 (Homing Type)							
5	0x00							
6	0x00							
7	0x00							

IMPORTANT

1. If an alarm occurs, when the servo is OFF, or another operation command is being performed (e.g., positioning, continuous rotary operation, etc.), the homing will be disabled.
2. Be sure that the Enable State bit in the response message is set to 1, and then set the Start Trajectory command bit. If you turn ON the Enable command and the Start Trajectory command at the same time, the Start Trajectory command will be ignored.

5.4.4 Hard Stop Operation

The Hard Stop Operation stops the motor using the maximum deceleration speed.

1. If the Hard Stop command is set to 1 while the motor is moving, the motor decelerates and stops using the maximum deceleration speed.
2. After the motor stops, the current position is set as the target position, and the On-Target Position signal is set to 1.
3. Clear the Hard Stop status by setting the Hard Stop command to 0. When setting the Hard Stop command to 0 while the command is being performed (i.e., the motor is decelerating), however, the setting will be ignored.

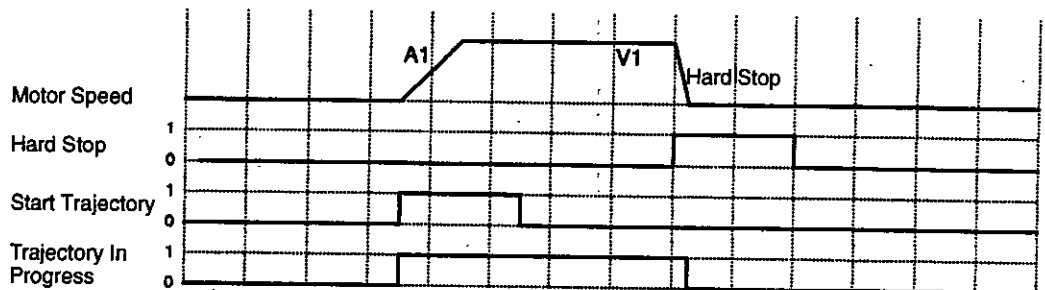

5.4.5 Deceleration and Stop Operation

The deceleration and stop operation decelerates the motor to a stop.

1. If a Smooth Stop command is set while the motor is moving, the motor decelerates and stops at the deceleration speed that has been set.
2. After the motor has stopped, the current position is set as the target position, i.e., the On-Target Position signal is set.
3. Clear the Smooth Stop status by resetting the Smooth Stop signal. When setting the Smooth Stop command to 0 while the command is being performed (i.e., the motor is decelerating), however, the setting will be ignored.

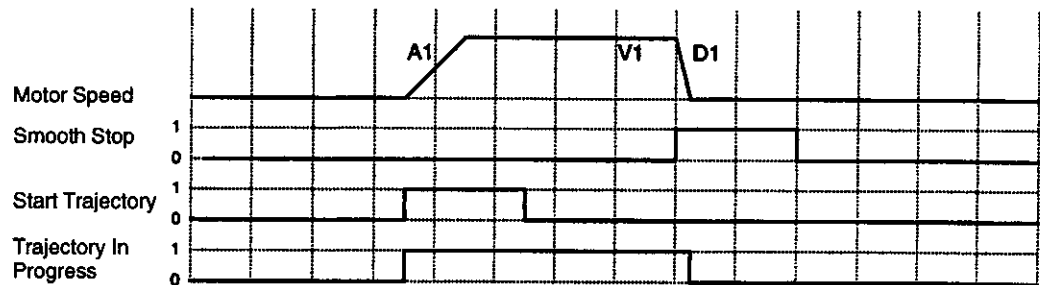

5.4.6 Emergency Stop Operation

The emergency stop is performed using an external signal.

If the emergency stop signal is set to Active while the motor is moving, a Hard Stop operation is performed. After the motor has stopped, the servo is turned OFF. If the brake function has been set, the brake is turned ON, and then the servo is turned OFF.

To return to normal operation, set the emergency stop signal to Inactive, and then send a servo ON command.

Set the following attributes to set the stop action, enable or disable the emergency stop signal, and set the logic.

Attribute	Access	Name	Data Type	Value
241	Get/Set	Emergency Stop Action	USINT	0: Hard Stop and Servo OFF
242	Get/Set	Emergency Stop Enable	BOOL	0: Disable 1: Enable
243	Get/Set	Emergency Stop Logic	BOOL	0: Active Low 1: Active High

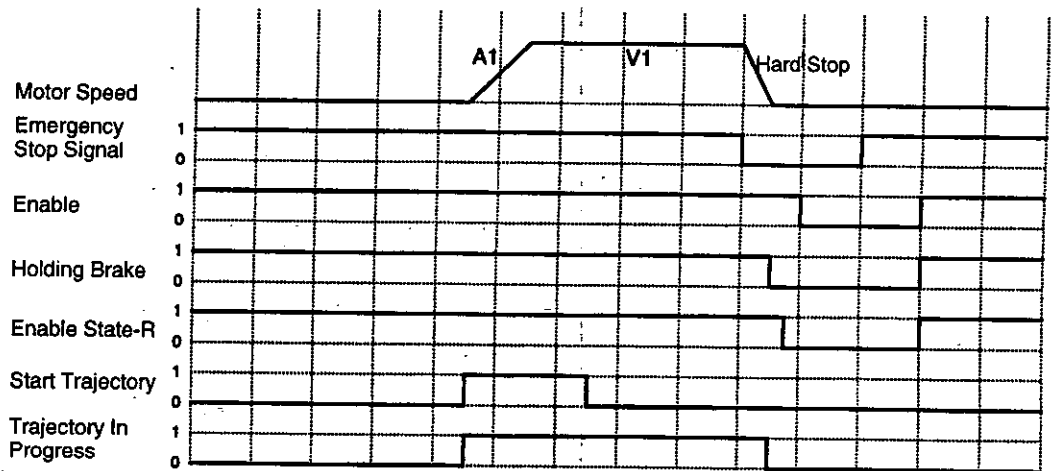

5.4.7 Hardware Limit Operation

The Hardware Limit Operation stops the motor using externally connected limit switches.

If the counterclockwise hardware limit is reached while the motor is rotating counterclockwise, a hard stop operation is performed. Similarly, a hard stop is performed if the clockwise hardware limit is reached while the motor is rotating clockwise. After the hard stop has been performed, only movement away from the hardware limit is permitted.

Set the following attributes to enable or disable the external emergency stop signal, set the input signal logic, etc.

Attribute	Access	Name	Data Type	Value
49	Get/Set	Hardware Limit Action	USINT	1: Hard Stop
50	Get/Set	CW Limit	BOOL	0: Inactive 1: Active
51	Get/Set	CCW Limit	BOOL	0: Inactive 1: Active
231	Get/Set	Hardware Limit Enable	BOOL	0: Disable 1: Enable
232	Get/Set	Hardware Limit Input Logic	BOOL	0: Active Low 1: Active High

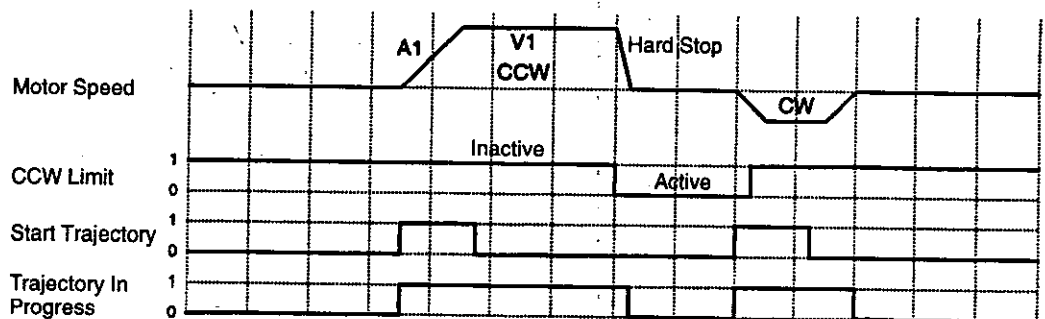

5.4.8 Software Limit Operation

If a user-set software limit is reached, the motor will decelerate and stop.

If the current motor position exceeds the software limit range, the motor will decelerate and stop. Once the motor has stopped, the motor can move only in the direction that clears the software limit error. The software limit has meaning only after a homing is performed.

Set the following attributes to set the software limits, operation if a software limit error occurs (i.e., Hard Stop or Smooth Stop), etc.

Attribute	Access	Name	Data Type	Value
52	Get/Set	Software Limit Enable	USINT	0: Disable 1: Enable
53	Get/Set	Software Limit Action	USINT	1: Hard Stop 2: Smooth Stop
54	Get/Set	Positive Software Limit Position	DINT	0x80000001 to 0x7FFFFFFF
55	Get/Set	Negative Software Limit Position	DNIT	0x80000001 to 0x7FFFFFFF

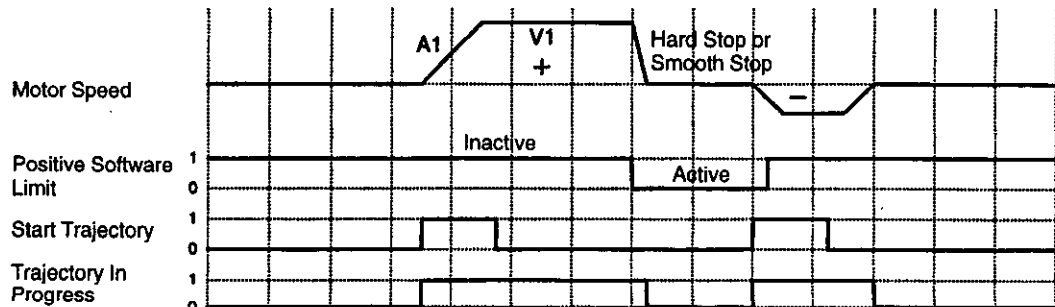

5.5 Program Function

5.5.1 Outline

■ What Is the Program Function?

The program function enables executing in sequence command blocks that have been set beforehand. You can register a maximum of 255 command blocks, and decide the sequence in which they are executed by the connections between the command blocks.

By specifying the start command block, the Host Controller can process all operations continuously in the NS310 Unit. Consequently, the Host Controller does not need to send the commands in sequence using command messages.

■ Operation Example

Perform the following procedure to execute the command blocks beginning with the specified block number.

1. Set the block number for the first block to be executed in Block Number (byte 1).
2. Set the Valid Data Flag to 1 (byte 0, bit 6).
3. Set the Start Block Flag to 1 (byte 0, bit 1).

Byte	Bit 7	Bit 6	Bit 5	Bit 4	Bit 3	Bit 2	Bit 1	Bit 0
0	1 Enable	1 Valid Data	0 Hard Stop	0 Smooth Stop	0 Direction (V Mode)	0 Absolute/Incremental	1 Start Block	0 Start Trajectory
1	0x01 (Block Number)							
2	001 Axis Instance			0x00 Command Code				
3	001 Axis Instance			0001 Response Code				
4	0x00							
5	0x00							
6	0x00							
7	0x00							

The block number set in the link number of the command block that has been specified will be executed next, and then command blocks will be executed in sequence until the link number = 0x00. While the command blocks are being executed, Block in Execution will be set to 1, and when all the command blocks have been executed, it will be set to 0.



Refer to 5.5.2 *Command Blocks* for information on link numbers.

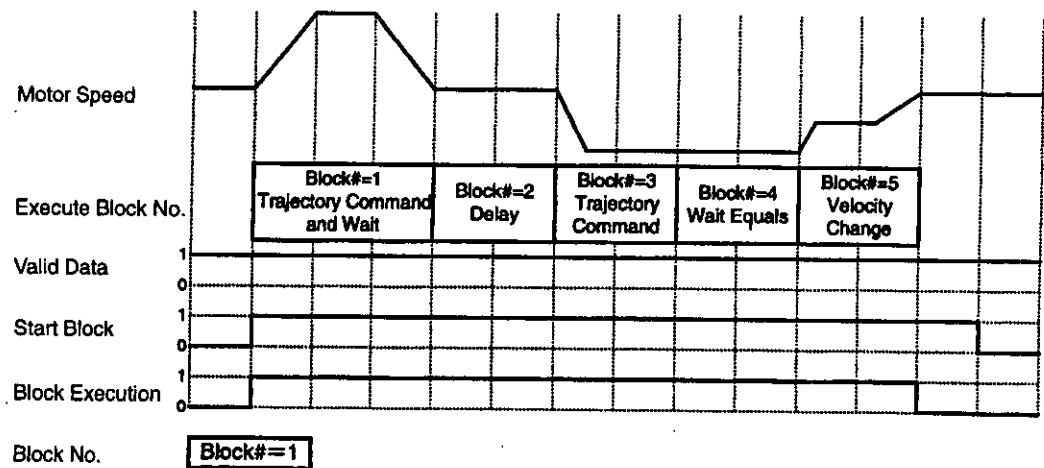

■ Command Functions Table

The following table shows the block commands that are supported.

Command Name	Code	Function
Modify Attributes Command	0x01	Changes an attribute.
Wait Equals Command	0x02	Stops command execution until an attribute reaches the set value.
Conditional Link Greater Than Command	0x03	Branches to the specified block if an attribute is greater than the Compare Data.
Conditional Link Less Than Command	0x04	Branches to the specified block if an attribute is smaller than the Compare Data.
Delay Command	0x06	Inserts a wait timer between execution blocks.
Trajectory Command	0x07	Performs a positioning. After the positioning is completed, the next command is immediately interpreted.
Trajectory Command and Wait	0x08	Starts a positioning and waits until the target position is reached.
Speed Change Command	0x09	Changes the target speed.
Goto Home Command	0x10	Moves to the home position.

5.5.2 Command Blocks

■ Command Block Structure

The command blocks consist of a maximum of seven attributes, as shown below. The number of attributes changes depending on the block command code.

Attribute	Access	Name	Details	Data Type
1	Get/Set	Block Command	Defines the format of the command data.	USINT
2	Get/Set	Block Link Number	Specifies the next command block to be executed.	USINT
3	Get/Set	Command-dependent	---	Command-dependent
4	Get/Set	Command-dependent	---	Command-dependent
5	Get/Set	Command-dependent	---	Command-dependent
6	Get/Set	Command-dependent	---	Command-dependent
7	Get/Set	Command-dependent	---	Command-dependent

■ Block Command Details

Attribute Change Command

Use the Attribute Change command to change an attribute. You can change the attributes indicated in the table 5.4. No other attributes can be changed.

Table 5.4 Changeable Attributes Table

Class	Instance	Attribute	Contents of Attribute
0x25	0x01	0x08	Acceleration
0x25	0x01	0x09	Deceleration
0x64	0x01	0x34	Acceleration and deceleration time constant
0x64	0x01	0x35	Deceleration time constant for asymmetrical acceleration and deceleration

The following table shows the data format for the Attribute Change command.

Table 5.5 Data Format for Attribute Change Command

Attribute	Name	Data Type	Contents of Attribute
1	Block Command Code	USINT	Code = 0x01
2	Block Link Number	USINT	Number of next command block to be executed*
3	Target Class	USINT	Class of attribute to be changed.
4	Target Instance	USINT	Instance number of attribute to be changed.
5	Attribute Number	USINT	Attribute number to be changed.
6	Attribute Value	DINT	Value of attribute to be changed.

* When the link number = 0, the block is the final block in the series.

Wait Equals Command

The Wait Equals command stops the execution of a series of blocks until the specified attribute matches a set value. Once the specified attribute matches the set value, the block ends and the next block in the link is executed.

Table 5.6 Table of Attributes that Can Be Compared

Class	Instance	Attribute	Contents of Attribute
0x25	0x01	0x13	Current feedback position
0x25	0x01	0x15	Current command position

Table 5.7 Data Format for Attribute Change Command

Attribute	Name	Data Type	Contents of Attribute
1	Block Command Code	USINT	Code = 0x02
2	Block Link Number	USINT	Block link
3	Target Class	USINT	Class of attribute to be compared.
4	Target Instance	USINT	Instance number of attribute to be compared.
5	Attribute Number	USINT	Attribute number to be compared.
6	Compare Timeout Value	DINT	If the Compare Data does not match within the set time, a time-out will occur. Setting range: 0 to 0x7FFFFFFF Unit: ms Set 0 to make the wait infinite.
7	Compare Data	DINT	Value of attribute to be compared.

Conditional Link Greater Than Command

If the value of the specified attribute is greater than the Compare Data, execution will branch to the block shown by the compare link number. If the value of the specified attribute is smaller than the Compare Data, execution will branch to the block shown by the block link number.

The attributes that can be compared are shown in the table below.

Table 5.8 Table of Attributes that Can Be Compared

Class	Instance	Attribute	Contents of Attribute
0x25	0x01	0x13	Current feedback position
0x25	0x01	0x15	Current command position

The data format for Conditional Link Greater Than Command is shown in the following table.

Table 5.9 Data Format for Conditional Link Greater Than Command

Attribute	Name	Data Type	Contents of Attribute
1	Block Command Code	USINT	Code = 0x03
2	Block Link Number	USINT	Block link start address if the attribute is smaller than the Compare Data.
3	Target Class	USINT	Class of attribute to be compared.
4	Target Instance	USINT	Instance number of attribute to be compared.
5	Attribute Number	USINT	Attribute number to be compared.
6	Compare Link Number	USINT	Block link start address if the attribute is greater than the Compare Data.
7	Compare Data	DINT	Value to compare to

Conditional Link Less Than Command

If the value of the specified attribute is smaller than the Compare Data, execution will branch to the block shown by the compare link number. If the value of the specified attribute is greater than the Compare Data, execution will branch to the block shown by the block link number.

The attributes that can be compared are shown in the table below.

Table 5.10 Table of Attributes that Can Be Compared

Class	Instance	Attribute	Contents of Attribute
0x25	0x01	0x13	Current feedback position
0x25	0x01	0x15	Current command position

The data format for Conditional Link Less Than Command is shown in the following table.

Table 5.11 Data Format for Conditional Link Less Than Command

Attribute	Name	Data Type	Contents of Attribute
1	Block Command Code	USINT	Code = 0x04
2	Block Link Number	USINT	Block link start address if the attribute is smaller than the compared value.
3	Target Class	USINT	Class of attribute to be compared.
4	Target Instance	USINT	Instance number of attribute to be compared.
5	Attribute Number	USINT	Attribute number to be compared.
6	Compare Link Number	USINT	Block link start address if the attribute is greater than the compared value.
7	Compare Data	DINT	Value to compare to

Delay Command

The Delay command delays the execution between blocks. Set the delay timer in 8 ms units. If you specify any value that is not in 8 ms units, the fraction will be truncated before the command is executed.

Table 5.12 Data Format for Delay Command

Attribute	Name	Data Type	Contents of Attribute
1	Block Command Code	USINT	Code = 0x06
2	Block Link Number	USINT	Number of next command block to be executed*
3	Delay	USINT	Sets the delay timer value. Setting range: 0x00000001 to 0x7FFFFFFF Unit: ms

* When the link number = 0, the block is the final block in the series.

Trajectory Command

The Trajectory command starts positioning. After positioning has started, the next command block is executed.

The data format for the Trajectory command is given in the following table.

Table 5.13 Data Format for Trajectory Command

Attribute	Name	Data Type	Contents of Attribute
1	Block Command Code	USINT	Code = 0x07
2	Block Link Number	USINT	Number of next command block to be executed*

Attribute	Name	Data Type	Contents of Attribute
3	Target Position	USINT	Attribute of target position
4	Target Speed	USINT	Attribute of target speed
5	Incremental/Absolute	BOOL	Attribute of relative or absolute value

* When the link number = 0, the block is the final block in the series.

Trajectory Command and Wait

The Trajectory command and Wait starts positioning. With this command, once positioning has started, the next command block is not executed until positioning has been completed.

The data format for the Trajectory Command and Wait is given in the following table.

Table 5.14 Data Format for the Trajectory Command and Wait

Attribute	Name	Data Type	Contents of Attribute
1	Block Command Code	USINT	Code = 0x08
2	Block Link Number	USINT	Number of next command block to be executed*
3	Target Position	USINT	Attribute of target position
4	Target Speed	USINT	Attribute of target speed
5	Incremental/Absolute	BOOL	Attribute of relative or absolute value

* When the link number = 0, the block is the final block in the series.

Speed Change Command

Use the Speed Change command to change the target speed. This command is used to change only the speed after the Trajectory Command has been executed.

The data format for the Speed Change command is given in the following table.

Table 5.15 Data Format for Speed Change Command

Attribute	Name	Data Type	Contents of Attribute
1	Block Command Code	USINT	Code = 0x08
2	Block Link Number	USINT	Number of next command block to be executed*
3	Target Speed	DINT	Attribute of target speed

* When the link number = 0, the block is the final block in the series.

Home Position Travel Command

The Home Position Travel command moves the axis to the home position. Before performing this command, make sure that homing has been completed, and that the home position has been detected.

The data format for the Home Position Travel Command is given in the following table.

Table 5.16 Data Format for the Home Position Travel Command

Attribute	Name	Data Type	Contents of Attribute
1	Block Command Code	USINT	Code = 0x10
2	Block Link Number	USINT	Number of next command block to be executed*
3	Home Offset	DINT	The sum of the offset and the home position attribute is the absolute value target position. Setting range: 0x80000001 to 0x7FFFFFFF
4	Speed	DINT	Target speed

* When the link number = 0, the block is the final block in the series.

If the contents of attribute 1 (block command) are changed, attributes 2 to 8 are all initialized to 0. Consequently, when changing attributes from the Host, make the changes in sequence starting from attribute 1.



5.5.3 Command Block Links

Command blocks are connected as shown below depending on the block number of attribute 2 in each command block.

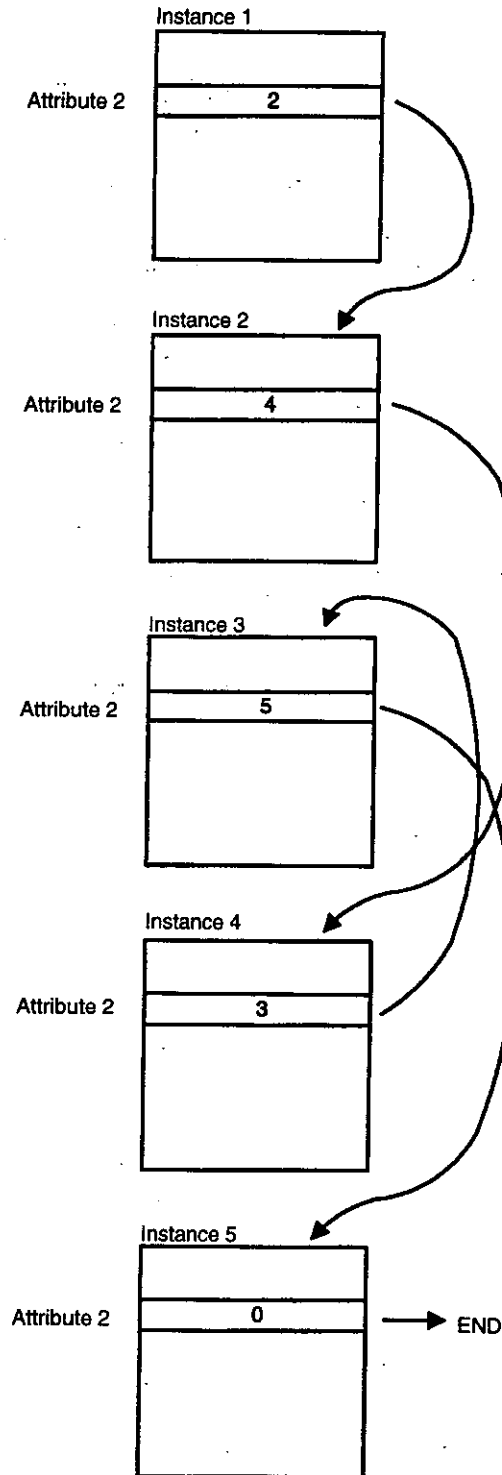

The command block number is equivalent to the number of the instance in the Command Block Object (0x27).

The number of the last command block to be executed is stored in attribute 2 (Block link number) of each command block.

If attribute 2 is 0, this command block becomes the last command block in a series of command blocks.

If command block 1 is executed from the Host Controller with the command blocks stored as shown above, the command blocks are executed in the following sequence.

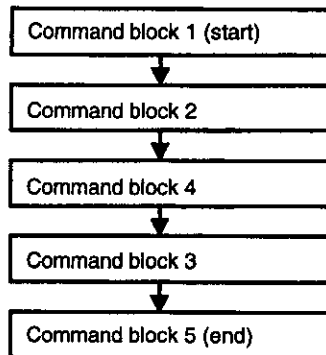

5.6 Changing Parameters and Command Blocks

5.6.1 DeviceNet Data Management

In DeviceNet, all parameters and command blocks are managed as objects, instances, and attributes. A diagram of operation is given below.

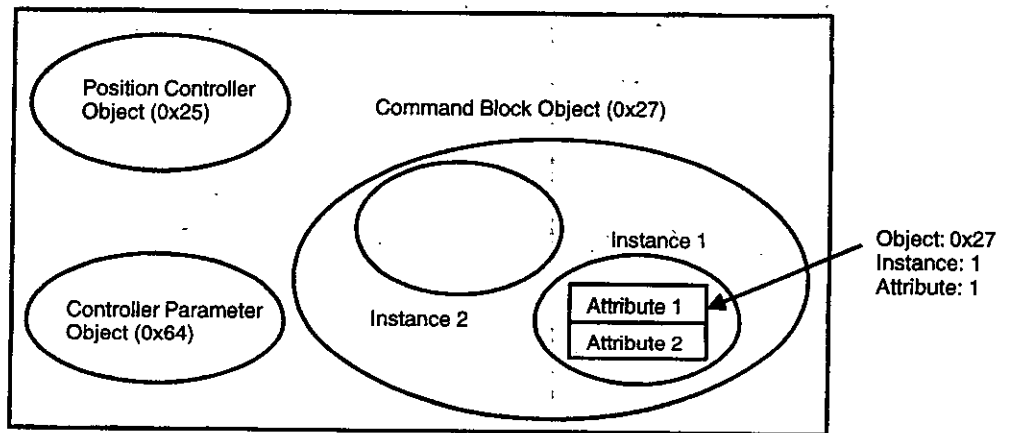

NS310 Units have the following objects.

Object Name	Instance No.	Details
Identity Object	1	Manages device type and serial number.
Message Router Object	1	Acts as a router to distribute explicit messages to objects.
DeviceNet Object	1	Manages the physical connection to DeviceNet.
Assembly Object	1	Manages response messages.
	2	Manages command messages.
Connection Object	1	Manages explicit messages.
	2	Manages I/O messages.
Position Controller Supervisor Object	1	Manages command codes and response codes.
Position Controller Object	1	Manages motion parameters.
Block Sequencer Object	1	Manages block commands and chains.
Command Block Object	1 to 255	Registers and manages block commands.
Control Parameter Object	1	Manages detailed motion settings.
SERVOPACK Parameter Object	1	Manages SGDH parameters.

Instances within objects hold setting data called attributes and data to show the status of the NS310 Unit. If referencing or changing attributes via DeviceNet, you must specify the object name, instance number, and attribute number.

For example, when referencing the attribute of the Actual Position, which shows the current position, specify the attribute as follows:

- Position Controller Object (0x25), Instance 1, Attribute 13

Refer to *Appendix B* for a table of attributes.

5.6.2 Editing Parameters

■ Using Command Messages

You can change the target speed, acceleration, deceleration, etc., using command messages.

Refer to *5.3 Command/Response Format* for details.

■ Using Message Communications

DeviceNet supports message communications called explicit messages. Using these message communications, you can reference and change parameters.

When using explicit messages, change the parameters by specifying the object, instance, and attribute. Refer to *5.6.1 DeviceNet Data Management* for details.

Basic Format

The basic format of explicit messages is shown below.

1. Command (Master Device to NS310)

7	6	5	4	3	2	1	0
0	0/1	Master's Node Address					
0	Service Code						
Object Number							
Instance Number							
Attribute Number							
Service Data							

2. Response (NS310 to Master Device)

7	6	5	4	3	2	1	0
0	0/1	Master's Node Address					
1	Service Code						
Object Number							
Instance Number							
Attribute Number							
Service Data							

Example of Reading Acceleration

An example using Master Node address 0 and reading acceleration (Object 0x25, Instance 1, Attribute 8) with the Get_Attribute_Single command (code: 0x0e) is shown below.

1. Command (Master Device to NS310)

7	6	5	4	3	2	1	0
0	0	0					
0	0x0e						
0x25							
0x01							
0x08							

2. Response (NS310 to Master Device)

7	6	5	4	3	2	1	0
0	00	0					
1	0x0e						
0x25							
0x01							
0x08							
0x00001234							

Refer to Master device manuals for details of explicit messages.

5.6.3 Editing Command Blocks

You can use either of the following two methods to write command block data.

1. Using the Set_Attribute_All command

Use this command to write an entire command block at once.

Normally, we recommend editing command blocks using this command.

2. Using the Set_Attribute_Single command

Use this command to change a single attribute of a command block.

If you change the contents of attribute 1 (block command code), all data from attribute 2 to attribute 8 will be initialized. Consequently, if editing data using this command, change the attributes in sequence starting with the attribute with the smallest number.



If editing command blocks under the following conditions, an error will be returned.

- The current block operation is still being performed.
- An alarm has occurred in the NS310 Unit.

5.6.4 Organizing Data

The NS310 DeviceNet implementation follows the ODVA Position Controller Device Profile wherever possible. Due to differences with this profile, the actual implementation is Device Type 00h. Refer to the ODVA DeviceNet specifications for details.

Data is organized in the NS310/SGDH combination in two distinct ways. Understanding the data organization is important in order to read this manual and configure and use the NS310/SGDH combination.

1. ODVA Position Controller Profile Objects.

In this case, data is viewed from the network perspective. This is the primary method for data organization in the manual. Wherever possible, the NS310/SGDH supports attributes in the ODVA Position Controller Profile Objects.

Object Name	Address	Description
Position Controller Supervisor	0x24	Handles errors for the position controller and home inputs.
Position Controller	0x25	Performs the control output speed profiling and handles input and output to and from the drive unit, limit switches, etc.
Block Sequencer	0x26	Handles the execution of Command Blocks or Command Block Chains.
Command Block	0x27	Each instance of the Command Block object defines a specific command. These blocks can be linked to form a command block chain.

2. Vendor Specification Objects.

In this case, data is organized from a hardware perspective.

The NS310/SGDH combination has additional setup or configuration data that is not defined, or is defined differently from the ODVA Position Controller Profile Objects. This second data organization is based on the physical location of the stored data.

Object Name	Address	Description
Control Parameter	0x64	Defines data stored in the NS310 Unit.
SERVOPACK Parameter	0x66	Defines data stored in the SERVOPACK.

In most cases, the NS310/SGDH can be configured by setting attributes in the ODVA Position Controller Objects: Objects 0x24, 0x25, 0x26, and 0x27. Some applications will require more in-depth configuration and will require changing attributes in Objects 0x64 and 0x66.

Data that is the same or similar in both organization methods is automatically cross-referenced. If data is changed in Object 0x25, the similar attribute in Object 0x64 will be automatically changed.

■ **Communicating with the NS310 Unit**

The NS310 Unit supports DeviceNet explicit messages and polled I/O messages. Polled I/O messages are used to pass time-sensitive control data during the actual process control. The structure of these messages (Command Assembly and Response Assembly) is discussed in detail in 5.3 *Command/Response Format*. Explicit messages are used to pass setup or configuration data.

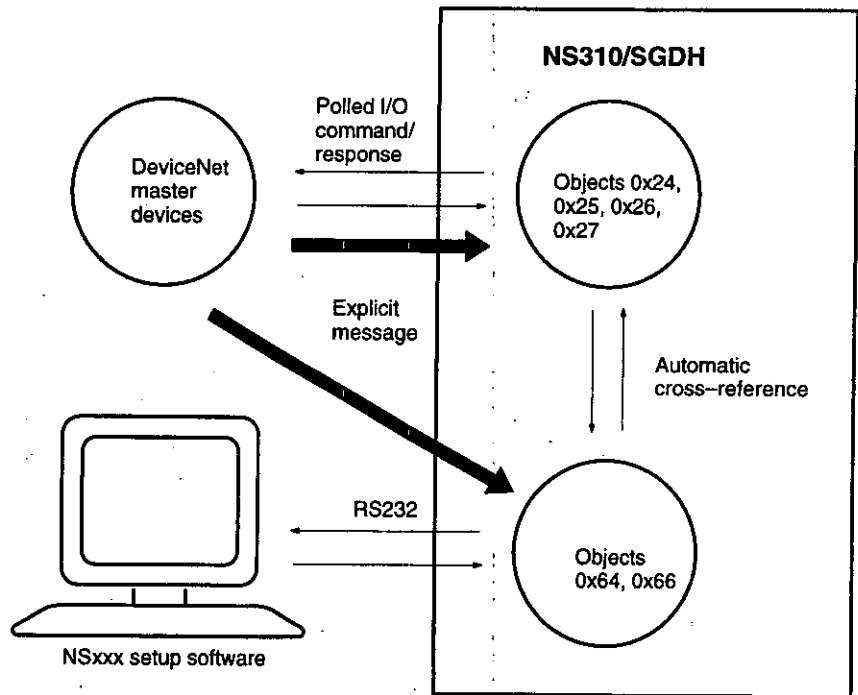

The NSxxx Setup Software is a general-purpose Yaskawa application that is meant to communicate with many Yaskawa option units. This application is meant for setup or configuration

of the NS310/SGDH. All attributes in Objects 0x64 and 0x66 can be edited with the NSxxx Setup Software. The NSxxx Setup Software communicates serially through the NS310 CN11 port. Because the NSxxx is not product-specific, data in attributes 64 and 66 is references by parameter number.



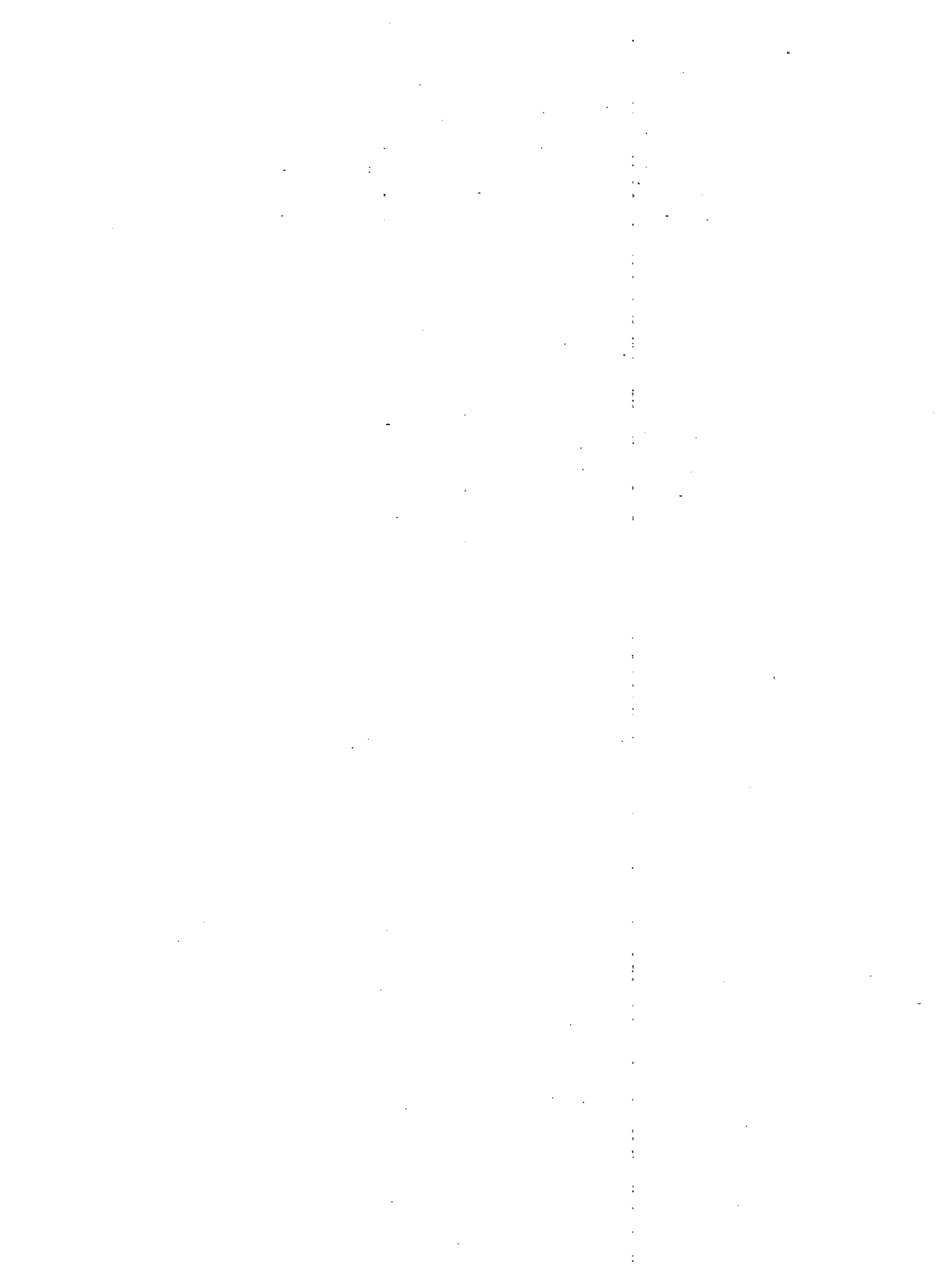

6

SGDH Parameters

This chapter describes SGDH parameters and standard settings for I/O signals (CN1) when an NS310 Unit is mounted.

6.1 Parameters and Standard Settings	
for NS310 Units	6 - 2
6.1.1 Parameters	6 - 2
6.1.2 Standard Settings for CN1 I/O Signals	6 - 3
6.2 Settings According to Equipment	
Characteristics	6 - 4
6.2.1 Switching Servomotor Rotation Direction	6 - 4
6.2.2 Stop Mode Selection at Servo OFF	6 - 4
6.3 Settings According to Host Controller	6 - 6
6.4 Setting Up the SERVOPACK	6 - 8
6.4.1 Parameters	6 - 8
6.4.2 Input Circuit Signal Allocation	6 - 8
6.4.3 Output Circuit Signal Allocation	6 - 9
6.5 Setting Stop Functions	6 - 12
6.5.1 Using the Dynamic Brake	6 - 12
6.5.2 Using the Holding Brake	6 - 13
6.6 Absolute Encoders	6 - 17
6.6.1 Selecting an Absolute Encoder	6 - 17
6.6.2 Absolute Encoder Setup	6 - 18
6.6.3 Multiturn Limit Setting	6 - 18
6.7 Digital Operator	6 - 21
6.7.1 Connecting the Digital Operator	6 - 21
6.7.2 Limitations in Using a Hand-held Digital Operator	6 - 21
6.7.3 Panel Operator Indicators	6 - 21

6.1 Parameters and Standard Settings for NS310 Units

6.1.1 Parameters

When an NS310 Unit is mounted on an SGDH SERVOPACK and it is used for DeviceNet communications, the following parameters are automatically set. The following parameters will be treated as "reserved for system use," so do not change them. The SGDH SERVOPACK will be set for position control. It is not necessary to set parameters for speed and torque control, so do not change the settings.

Pn No.	Digit	Parameter Name	Set Value	Contents
Pn000	1	Select control method	1	Position control
Pn004	1	Reserved	0	---
Pn200	2	Clear signal status	1	Error counter is not cleared.
Pn202	---	Electronic Gear Ratio (Numerator)	1	Electronic gear on SGDH SERVOPACK is not used.
Pn203	---	Electronic Gear Ratio (Denominator)	1	Electronic gear on SGDH SERVOPACK is not used.
Pn204	---	Position command acceleration/deceleration time constant	0	Time constant = 0
Pn207	1	Select position command filter	0	Uses the position command acceleration/deceleration filter.
Pn50A	---	Select input signal 1	8881	Not used
Pn50B	---	Select input signal 2	8888	Not used
Pn50C	---	Select input signal 3	8888	Not used
Pn50D	---	Select input signal 4	8888	Not used
Pn511	0	Select input signal 5	8	Not used



These parameters are set automatically the first time the power to the SERVOPACK is turned ON after the NS310 Unit has been mounted. Startup will take approximately 6 seconds when these parameters are being set.

6.1.2 Standard Settings for CN1 I/O Signals

The standard settings for CN1 I/O signals when the NS310 Unit is mounted are described below. If using the standard settings, change the parameters as shown below. The input signal setting from the NS310 Unit will be force-changed, so you cannot change this setting.

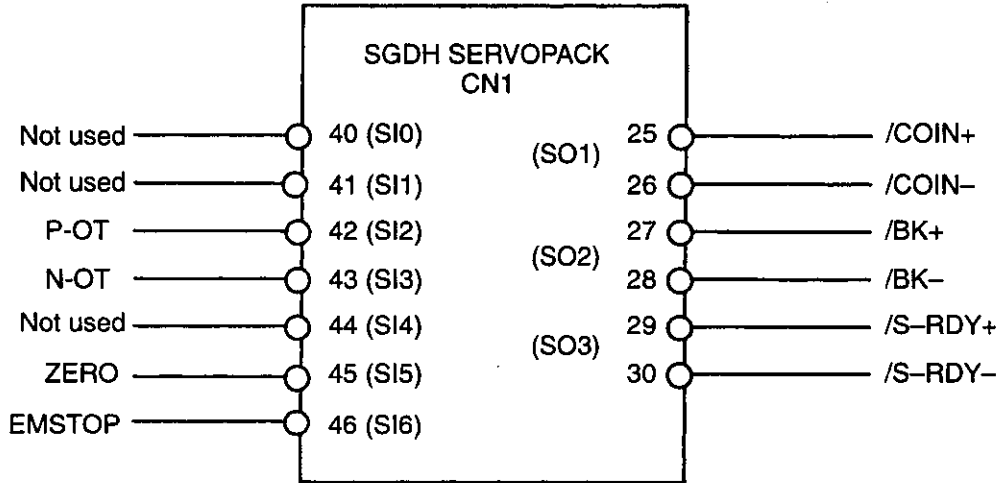

Figure 6.1 Standard CN1 I/O Signal Settings

Table 6.1 Factory Settings and Standard Settings for I/O Signals

Parameter	Description	Factory Setting	Standard Setting
Pn50E	Output signal selection 1	3211	3001
Pn50F	Output signal selection 2	0000	0200
Pn510	Output signal selection 3	0000	0000



6.2 Settings According to Equipment Characteristics

This section describes the procedure for setting parameters according to the dimensions and performance of the equipment used.

6.2.1 Switching Servomotor Rotation Direction

The SERVOPACK has a Reverse Rotation Mode that reverses the direction of servomotor rotation without rewiring. Forward rotation in the standard setting is defined as counterclockwise as viewed from the load.

With the Reverse Rotation Mode, the direction of servomotor rotation can be reversed without changing other items. The direction (+, -) of shaft motion is reversed. There are no other changes.

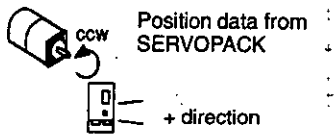
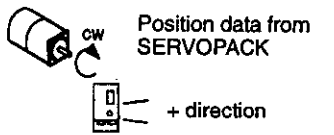
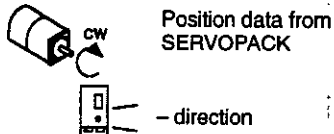
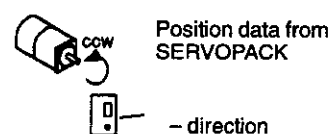
	Standard Setting	Reverse Rotation Mode
Forward Reference		
Reverse Reference		

■ Setting Reverse Rotation Mode

Use parameter Pn000.0.

Pn000.0	Direction Selection	Factory Setting:	Position Control
		0	

Use the following settings to select the direction of servomotor rotation.

Setting	Description	
0	Forward rotation is defined as counterclockwise (CCW) rotation as viewed from the load.	(Standard setting)
1	Forward rotation is defined as clockwise (CW) rotation as viewed from the load.	(Reverse Rotation Mode)

6.2.2 Stop Mode Selection at Servo OFF

The SGDH SERVOPACK turns OFF under the following conditions:

- The SV_OFF command is transmitted.
- Servo alarm occurs.
- Power is turned OFF.

Specify the Stop Mode if any of these occurs during servomotor operation.

Pn001.0	Servo OFF Stop Mode	Factory Setting: 0	---
----------------	----------------------------	-------------------------------------	-----

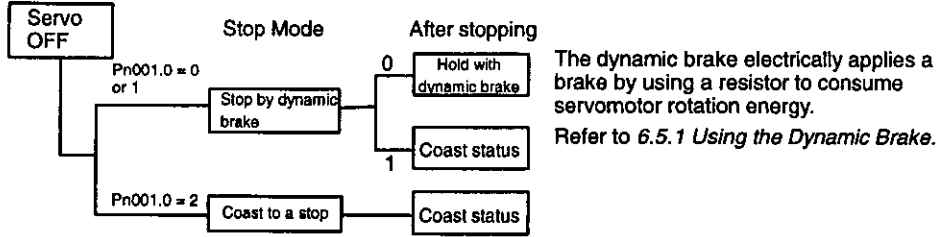

Parameter	Setting	Item
Pn001.0	0 (Factory setting)	Uses the dynamic brake to stop the servomotor, and maintains dynamic brake status after stopping.
	1	Uses the dynamic brake to stop the servomotor, and cancels dynamic brake status after stopping to go into coast status.
	2	Coasts the servomotor to a stop. The servomotor is turned OFF and stops due to equipment friction.

Note If the servomotor is stopped or rotating at extremely low speed when the item above is set to 0 (dynamic brake status after stopping with the dynamic brake), then braking power is not generated and the servomotor will coast to a stop the same as in coast status.



6.3 Settings According to Host Controller

Sequence I/O signals are used to control SERVOPACK operation. Connect these signal terminals as required.

■ Input Signal Connections

Connect the sequence input signals as shown below.

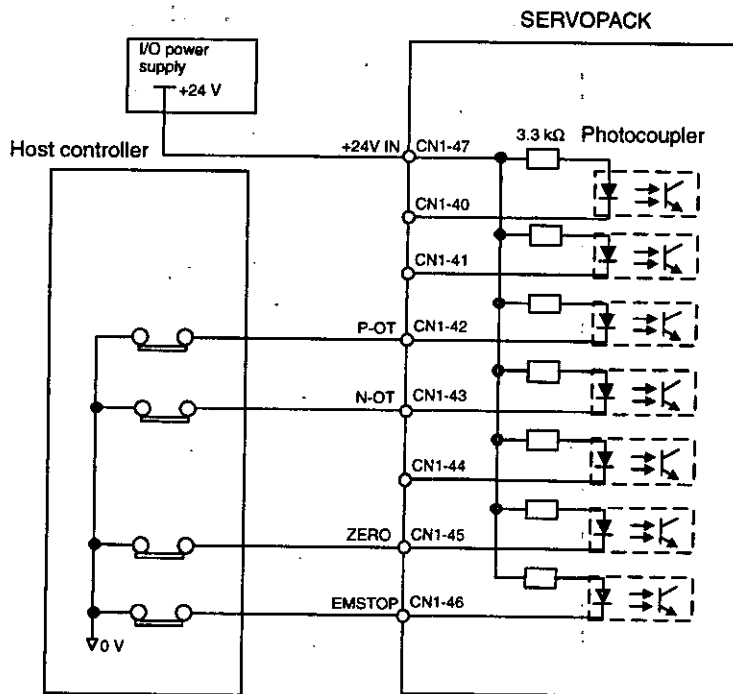

IMPORTANT

Provide an external input power supply; the SERVOPACK does not have an internal 24-V power supply.

- External power supply specifications: 24 ± 1 VDC, 50 mA min.

Yaskawa recommends using the same external power supply as that used for output circuits. The allowable voltage range for the 24-V sequence input circuit power supply is 11 to 25 V. Although a 12-V power supply can be used, contact faults can easily occur for relays and other mechanical contacts under low currents. Confirm the characteristics of relays and other mechanical contacts before using a 12-V power supply.

→ Input +24V IN CN1-47

24 V External I/O Power Supply Input

Position Control

The external power supply input terminal is common to sequence input signals.

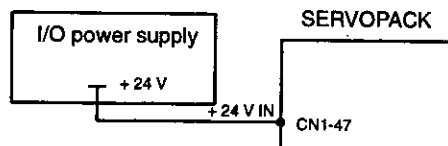

Connect an external I/O power supply.

Contact input signals: P-OT (CN1-42)
 N-OT (CN1-43)
 ZERO (CN1-45)
 EMSTOP (CN1-46)

■ Output Signal Connections

Connect the sequence output signals as shown in the following figure. (Standard settings)

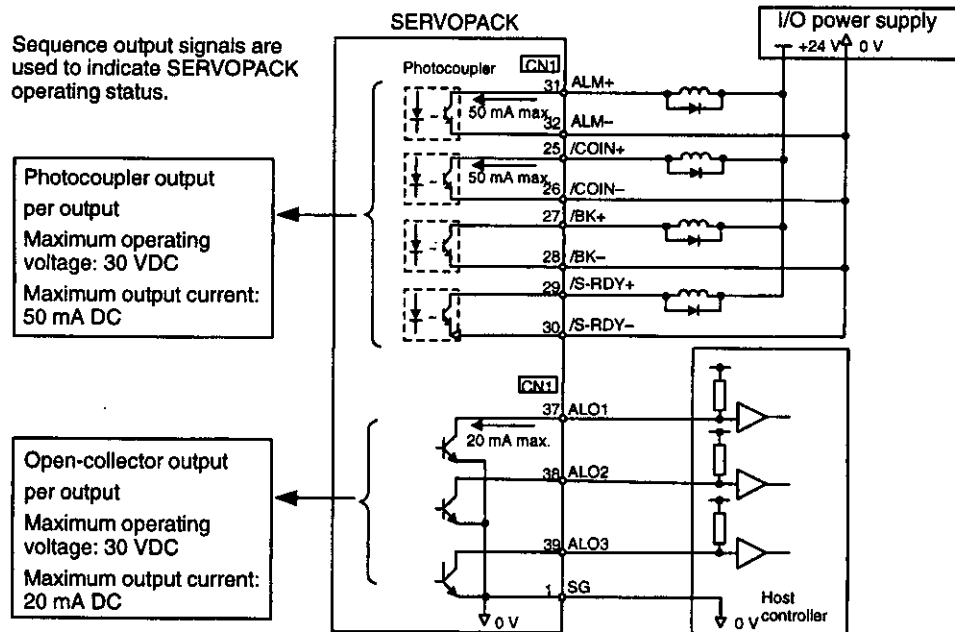

IMPORTANT

Provide a separate external I/O power supply; the SERVOPACK does not have an internal 24-V power supply. Yaskawa recommends using the same type of external power supply as that used for input circuits.

Function allocation for some sequence output signal circuits can be changed.

Refer to 6.4.3 *Output Circuit Signal Allocation* for more details.

6.4 Setting Up the SERVOPACK

This section describes the procedure for setting parameters to operate the SERVOPACK.

6.4.1 Parameters

The Σ -II Series SERVOPACK provides many functions and has parameters that allow the user to specify functions and perform fine adjustments.

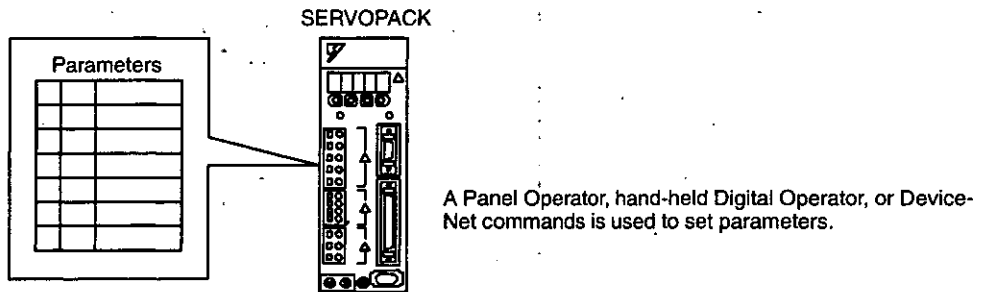

Parameters are divided into the following three groups.

Parameter	Function
Pn000 to Pn7FF	Specify SERVOPACK functions, set servo gains, etc.
Fn000 to Fn013	Execute auxiliary functions such as JOG Mode operations and home position searches.
Un000 to Un00D	Enable monitoring the motor speed and torque reference on the panel display.

Refer to *Appendix B DeviceNet Attributes*.

6.4.2 Input Circuit Signal Allocation

The allocation of the sequence input signal circuit when the NS310 Unit is mounted on the SGdH SERVOPACK is not changed. It will be as follows:

Terminal Numbers	Input Terminal Name	Symbol	Name
40	SI0	---	---
41	SI1	---	---
42	SI2	P-OT	Forward run prohibited
43	SI3	N-OT	Reverse run prohibited
44	SI4	---	---

Terminal Numbers	Input Terminal Name	Symbol	Name
45	SI5	ZERO	Home position signal
46	SI6	EMSTOP	Emergency stop signal

6.4.3 Output Circuit Signal Allocation

Output signal functions can be allocated to the sequence signal output circuits shown below.

In general, allocate signals according to the standard settings in the following table.

CN1 Connector Terminal Numbers	Output Terminal Name	Factory Setting		Standard Setting	
		Symbol	Name	Symbol	Name
25	SO1	/COIN+	Positioning completed	/COIN+	Positioning completed
26		/COIN-		/COIN-	
27	SO2	/TGON+	Rotation detection	/BK+	Brake interlock
28		/TGON-		/BK-	
29	SO3	/S-RDY+	Servo ready	/S-RDY+	Servo ready
30		/S-RDY-		/S-RDY-	

The output signal selection parameters and their factory settings and standard settings are shown below.

Pn50E	Output Signal Selection 1	Factory Setting: 3211	Standard Setting: 3001
Pn50F	Output Signal Selection 2	Factory Setting: 0000	Standard Setting: 0200
Pn510	Output Signal Selection 3	Factory Setting: 0000	Standard Setting: 0000

Select the CN1 connector terminals that will output the signals.

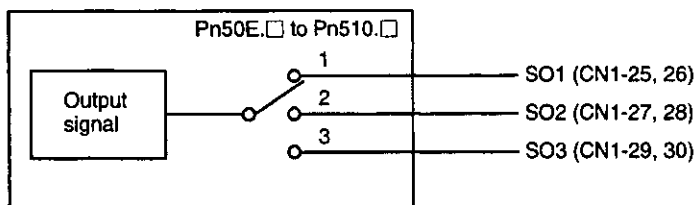

Output Signal	Parameter		Description
	Number	Setting	
Positioning Completed (/COIN)	Pn50E.0	0	Disabled (Not used for the output signal on the left.)
		1	Outputs the signal on the left from the SO1 (CN1-25 and 26) output terminal.
		2	Outputs the signal on the left from the SO2 (CN1-27 and 28) output terminal.
		3	Outputs the signal on the left from the SO3 (CN1-29 and 30) output terminal.
Speed Coincidence Detection (/V-CMP)	Pn50E.1	0 to 3	Same as above*
Rotation Detection (/TGON)	Pn50E.2	0 to 3	Same as above
Servo Ready (/S-RDY)	Pn50E.3	0 to 3	Same as above
Torque Limit Detection (/CLT)	Pn50F.0	0 to 3	Same as above
Speed Limit Detection (/VLT)	Pn50F.1	0 to 3	Same as above
Brake Interlock (/BK)	Pn50F.2	0 to 3	Same as above
Warning (/WARN)	Pn50F.3	0 to 3	Same as above
Near (/NEAR)	Pn510.0	0 to 3	Same as above
Phase C Detection (/C-PULS)	Pn510.1	0 to 3	Same as above

* Always OFF when an NS310 Unit is mounted.

Note "Same as above" means output signals are disabled or allocated to output terminals SO1 to SO3 through parameter settings 0 to 3.



Signals are output with OR logic when multiple signals are allocated to the same output circuit. Signals that are not detected are invalid.

■ Output Signal Reversal

The following parameter can be used to reverse the signals output on output terminals SO1 to SO3.

Pn512	Output Signal Reversal Settings	Factory Setting: 0000	Position Control
--------------	--	--	-------------------------

The settings specify which of the connector CN1 output signals are to be reversed.

Output Terminals	Parameter		Description
	Number	Setting	
SO1 (CN1-25, 26)	Pn512.0	0	Output signal not reversed.
		1	Output signal reversed.
SO2 (CN1-27, 28)	Pn512.1	0	Output signal not reversed.
		1	Output signal reversed.
SO3 (CN1-29, 30)	Pn512.2	0	Output signal not reversed.
		1	Output signal reversed.
Not used	Pn512.3	---	---

6.5 Setting Stop Functions

This section describes the procedure used to stop the SERVOPACK stably.

6.5.1 Using the Dynamic Brake

To stop the servomotor by applying the dynamic brake (DB), set the desired mode in the following parameter. The servomotor will stop due to equipment friction if the dynamic brake is not applied.

Pn001.0	Servo OFF or Alarm Stop Mode	Factory Setting: 0	Position Control
----------------	-------------------------------------	-------------------------------------	-------------------------

The SERVOPACK turns OFF under the following conditions:

- When the SV_OFF command is issued.
- A Servo alarm occurs.
- Power is turned OFF.

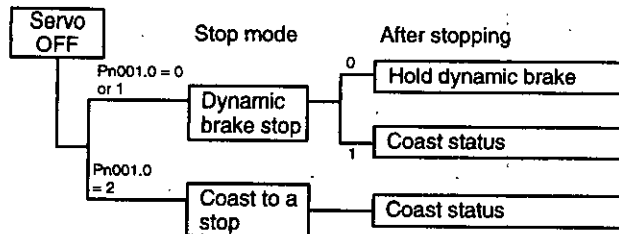

Specify the Stop Mode if any of these occurs during operation.

Pn001.0 Setting	Description
0	Uses the dynamic brake to stop the servomotor. Maintains dynamic brake after the servomotor stops. *1
1	Uses the dynamic brake to stop the servomotor. Releases dynamic brake after the servomotor stops, and the servomotor coasts to a stop.
2	Coasts the servomotor to a stop. *2 The servomotor is turned OFF and stops due to equipment friction.

* 1. If the servomotor is stopped or moving at extremely low speed, it will coast to a stop.

* 2. A dynamic brake is used when the control power and main power are turned OFF.



◆ Dynamic brake (DB)

The dynamic brake is a common way of suddenly stopping a servomotor. Built into the SERVOPACK, the dynamic brake suddenly stops a servomotor by electrically shorting its electrical circuit.

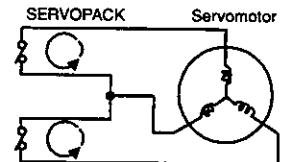

IMPORTANT

The dynamic brake is an emergency stop function. Do not repeatedly start and stop the servomotor using the SV_ON/SV_OFF command or by repeatedly turning power ON and OFF.

6.5.2 Using the Holding Brake

The holding brake is used when a Servodrive controls a vertical axis. In other words, a servomotor with brake prevents the movable part from shifting due to gravity when system power goes OFF.

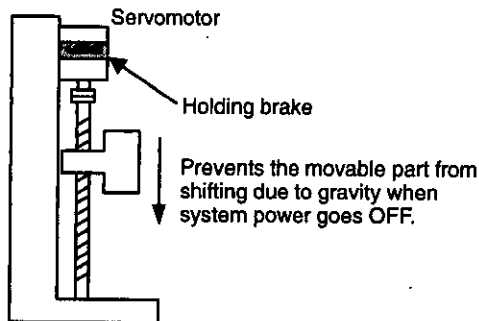
**IMPORTANT**

The brake built into the SGM□H servomotor with brakes is a de-energization brake, which is used only to hold and cannot be used for braking. Use the holding brake only to hold a stopped motor. Brake torque is at least 120% of the rated motor torque.

■ Wiring Example

Use the SERVOPACK sequence output signal /BK and the brake power supply to form a brake ON/OFF circuit. The following diagram shows a standard wiring example.

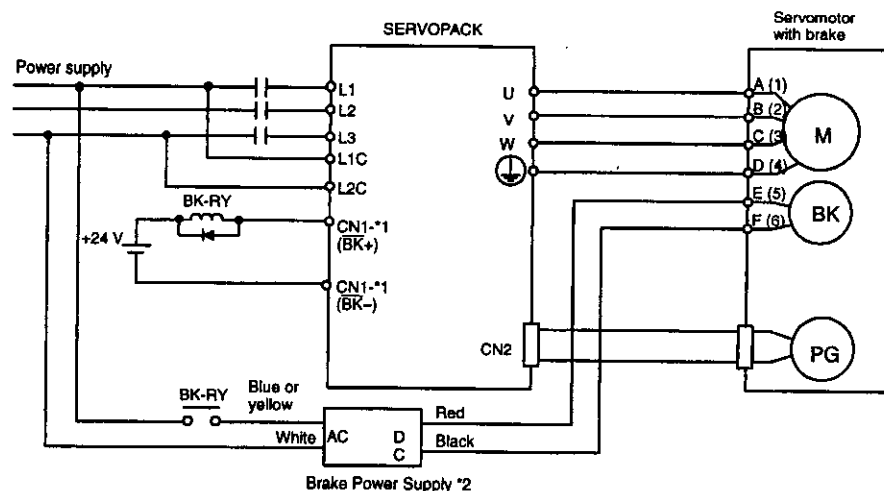

BK-RY: Brake control relay

*1: The output terminal signal allocated with Pn50F.2

*2: Brake power supplies are available in 200-V and 100-V models.

Output to /BK	Brake Interlock Output	Position Control
---------------	------------------------	------------------

This output signal controls the brake when using a servomotor with a brake and does not have to be connected when using a servomotor without a brake.

ON: Closed or low level	Releases the brake.
OFF: Open or high level	Applies the brake.

Related Parameters

Pn505	Brake operation
Pn506	Time Delay from Brake Reference until Servo OFF
Pn507	Speed Level for Brake Reference Output during Motor Operation
Pn508	Timing for Brake Reference Output during Motor Operation

The output signal in the following parameter must be selected when the /BK signal is used.

Pn50F	Output Signal Selections 2	Factory Setting: 0000	Position Control
--------------	-----------------------------------	---------------------------------	-------------------------

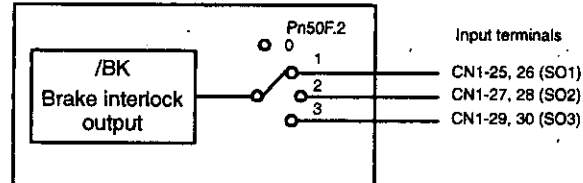

Select the /BK output terminal.

Parameter	Setting	Output Terminal (CN1)	
		*1	*2
Pn50F.2	0	---	---
	1	25	26
	2	27	28
	3	29	30

Note Signals are output with OR logic when multiple signals are allocated to the same output circuit. Set other output signals to a value other than that allocated to the /BK signal in order to output the /BK signal alone. Refer to 6.4.3 Output Circuit Signal Allocation.

■ Brake Operation

Set whether the brake is applied using the SERVOPACK parameter brake command or the controller's BRK_ON/BRK_OFF commands.

Pn005.0	Brake Operation	Factory Setting: 0	Position Control
---------	-----------------	-----------------------	------------------

Pn005.0 Setting	Description
0	Brake operation using the SERVOPACK parameter.
1	Brake operation using the controller's BRK_ON/BRK_OFF commands.

IMPORTANT

When brake operation is controlled using the controller's BRK_ON/BRK_OFF commands, the SERVOPACK's parameters (Pn506, Pn507, Pn508) settings will be ignored.

■ Brake ON Timing

If the equipment moves slightly due to gravity when the brake is applied, set the following parameter to adjust brake ON timing.

Pn506	Time Delay from Brake Reference until Servo OFF	Unit: 10 ms	Setting Range: 0 to 50	Factory Setting: 0	Position Control
-------	---	----------------	---------------------------	-----------------------	------------------

This parameter is used to set the output time from the brake control output signal /BK until the servo OFF operation (servomotor output stop) when a servomotor with a brake is used.

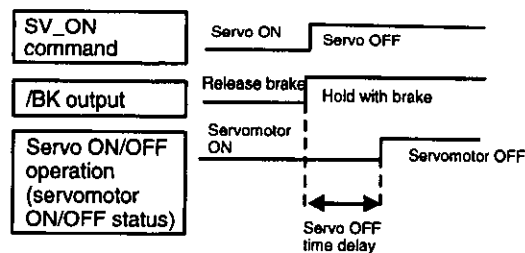

With the standard setting, the servo is turned OFF when the /BK signal (brake operation) is output. The equipment may move slightly due to gravity depending on equipment configuration and brake characteristics. If this happens, use this parameter to delay servo OFF timing.

This setting sets the brake ON timing when the servomotor is stopped. Use Pn507 and 508 for brake ON timing during operation.

IMPORTANT

The servomotor will turn OFF immediately if an alarm occurs. The equipment may move due to gravity in the time it takes for the brake to operate.

■ Holding Brake Setting

Set the following parameters to adjust brake ON timing so the holding brake is applied when the servomotor stops.

Pn507	Brake Reference Output Speed Level during Motor Operation	Unit: min ⁻¹	Setting Range: 0 to 10000	Factory Setting: 100	Position Control
Pn508	Timing for Brake Reference Output during Motor Operation	Unit: 10 ms	Setting Range: 10 to 100	Factory Setting: 50	Position Control

Set the brake timing used when the servo is turned OFF by the SV_OFF command or when an alarm occurs during servomotor with brake operation.

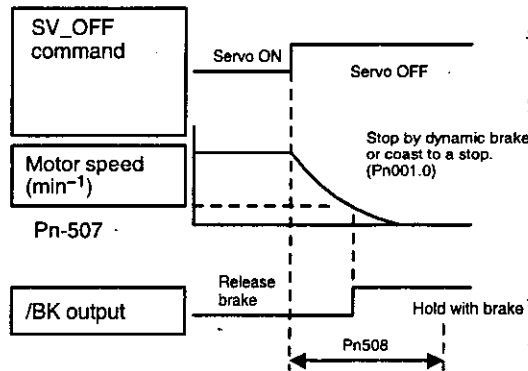

Brake ON timing when the servomotor stops must be adjusted properly because servomotor brakes are designed as holding brakes. Adjust the parameter settings while observing equipment operation.

/BK Signal Output Conditions During Servomotor Operation

The circuit is open under either of the following conditions:

1	Motor speed drops below the setting at Pn507 after servo OFF.
2	The time set at Pn508 has elapsed since servo OFF.

The actual setting will be the maximum speed even if Pn507 is set higher than the maximum speed.

6.6 Absolute Encoders

If a motor with an absolute encoder is used, a system to detect the absolute position can be made in the host controller. Consequently, operation can be performed without homing immediately after the power is turned ON.

Motor SGM□H-□□□1□...With 16-bit absolute encoder

SGM□H-□□□2□...With 17-bit absolute encoder

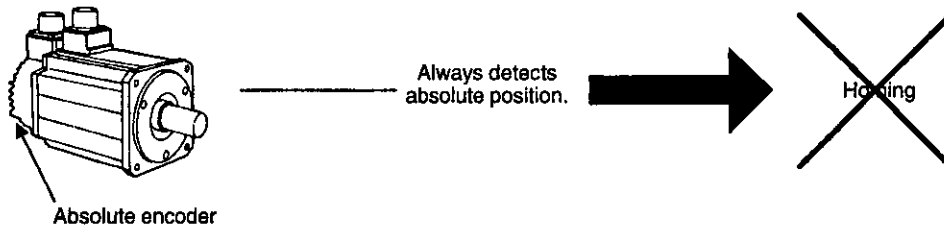

6.6.1 Selecting an Absolute Encoder

Select the absolute encoder usage with the following parameter.

Pn002.2	Absolute Encoder Usage	Factory Setting: 0	Position Control
---------	------------------------	-----------------------	------------------

“0” in the following table must be set to enable the absolute encoder.

Pn002.2 Setting	Description
0	Use the absolute encoder as an absolute encoder.
1	Use the absolute encoder as an incremental encoder.

Note This parameter setting goes into effect when the power is turned OFF and ON again after the change has been made.

6.6.2 Absolute Encoder Setup

Perform the setup operation for the absolute encoder in the following circumstances:

- When starting the machine for the first time.
- When an encoder backup alarm is generated.
- When the SERVOPACK's power supply is turned OFF and the encoder's cable is removed.

Perform the setup operation in one of the following ways.

- Refer to the *Σ-II Series SGM□H/SGDH User's Manual: Design and Maintenance (SIE-S800-32.2)* for details on the absolute encoder setup operation (Fn008) when a Digital Operator is used.

Setup can also be performed using personal computer monitor software.



The absolute encoder setup operation is only possible when the servo is OFF. After the setup processing is finished, turn the power back ON again.

IMPORTANT

If the following absolute encoder alarms are displayed, the alarms must be cleared using the method described above for the setup operation. They cannot be cleared by the SERVOPACK alarm clear (ALM-CLR) command.

- Encoder backup alarm (A.81)
- Encoder sum checksum alarm (A.82)

In addition, if a monitoring alarm is generated in the encoder, the alarm must be cleared by turning OFF the power.

6.6.3 Multiturn Limit Setting

When implementing absolute detection systems for machines that turn m times in response to n turns in the load shaft, such as round tables, it is convenient to reset the multiturn data from the encoder to 0 every m turns. The Multiturn Limit Setting allows the value m to be set for the encoder.

Select the absolute encoder usage with the following parameter.

Pn002.2	Absolute Encoder Usage	Factory Setting:	Position Control
		0	

"0" in the following table must be set in order to enable the absolute encoder.

Pn002.2 Setting	Description
0	Use the absolute encoder as an absolute encoder.
1	Use the absolute encoder as an incremental encoder.

The multiturn limit is set in the SERVOPACK using the following parameter.

Pn205	Multiturn Limit Setting	Unit: rev	Setting Range: 0 to 65535	Factory Setting: 65535	Position Control
--------------	--------------------------------	---------------------	-------------------------------------	----------------------------------	-------------------------

If the Multiturn Limit Setting is set to 65535 (factory setting), the multiturn data will vary from -32768 to 32767. If any other value is set, the multiturn data will vary from 0 to the setting of Pn205.

If the servomotor rotates in the negative direction from 0, the multiturn data will change to the value set for Pn205. If the servomotor rotates in the positive direction from the value set in Pn205, the multiturn data will change to 0. Set Pn205 to $m - 1$.



Turn the power OFF and then back ON after changing the setting of parameter Pn002.2 or Pn205.

The multiturn limit value in the encoder is factory set to 65535, the same as the SERVOPACK. If the multiturn limit value in the SERVOPACK is changed with Pn205 and then the SERVOPACK power is turned OFF and ON, the following alarm will occur.

Alarm Name: Multiturn Limit Mismatch

Alarm Display	Alarm Code Outputs			Description of Alarm
	ALO1	ALO2	ALO3	
A.CC	ON	OFF	ON	The multiturn limit value is different in the encoder and SERVOPACK.

Note ON signals are low level; OFF signals are high level.

When this alarm occurs, the multiturn limit in the encoder must be changed. This operation is performed in one of the following ways.

- Refer to the *Σ-II Series SGM□H/SGDH User's Manual: Design and Maintenance* (SIE-S800-32.2) for details on changing the multiturn limit setting (Fn013) using a Digital Operator.

Setup can also be performed using the personal computer monitor software.

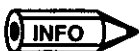



The multiturn limit setting in the encoder can be changed only when the Multiturn Limit Mismatch alarm has occurred. After changing the setting, turn the power supply OFF and then back ON.



◆ Multiturn limit

The upper limit of multiturn data. The multiturn data will vary between 0 and the value of Pn205 (multiturn limit setting) when Pn002.2 is set to 0.

 **WARNING** The multiturn limit value must be changed only for special applications. Changing it inappropriately or unintentionally can be dangerous.

 **WARNING** If the Multiturn Limit Mismatch alarm occurs, check the setting of parameter Pn205 in the SERVOPACK to be sure that it is correct. If Fn013 is executed when an incorrect value is set in Pn205, an incorrect value will be set in the encoder. The alarm will disappear even if an incorrect value is set, but incorrect positions will be detected, resulting in a dangerous situation where the machine will move to unexpected positions.

6.7 Digital Operator

6.7.1 Connecting the Digital Operator

There are two types of Digital Operator. One is a built-in operator incorporating a panel indicator and switches located on the front panel of the SERVOPACK. This type of Digital Operator is also called a Panel Operator. The other one is a Hand-held Digital Operator (i.e., the JUSP-OP02A-2 Digital Operator), which can be connected to the SERVOPACK through connector CN3 of the SERVOPACK.

There is no need to turn OFF the SERVOPACK to connect the Hand-held Digital Operator to the SERVOPACK. For details on how to use the Hand-held Digital Operator, refer to the Σ -II Series SGM□H/SGDH User's Manual : Design and Maintenance (SIE-S800-32.2).

6.7.2 Limitations in Using a Hand-held Digital Operator

When an NS310 Unit is mounted, the Hand-held Digital Operator has the following limitations.



Disconnect the Hand-held Digital Operator during normal operation.

Do not perform communications with a personal computer during normal operation.

Normal Operation

The following commands are not supported when sent via DeviceNet if a Hand-held Digital Operator is connected or communications with a personal computer are started during normal operation.

- Writing SGD parameters

6.7.3 Panel Operator Indicators

The Panel Operator indicators (LED) will not be lit in any of the following circumstances.

1. The indicators will not be lit for approximately 3 seconds when the power is turned ON.
2. The indicator will not be lit when the Hand-held Digital Operator is connected.
It will be lit when the Hand-held Digital Operator is disconnected.
3. The indicator will not be lit momentarily when the following commands are received via DeviceNet or from a setup tool.
 - Writing SGD parameters
 - Reading SGD parameters

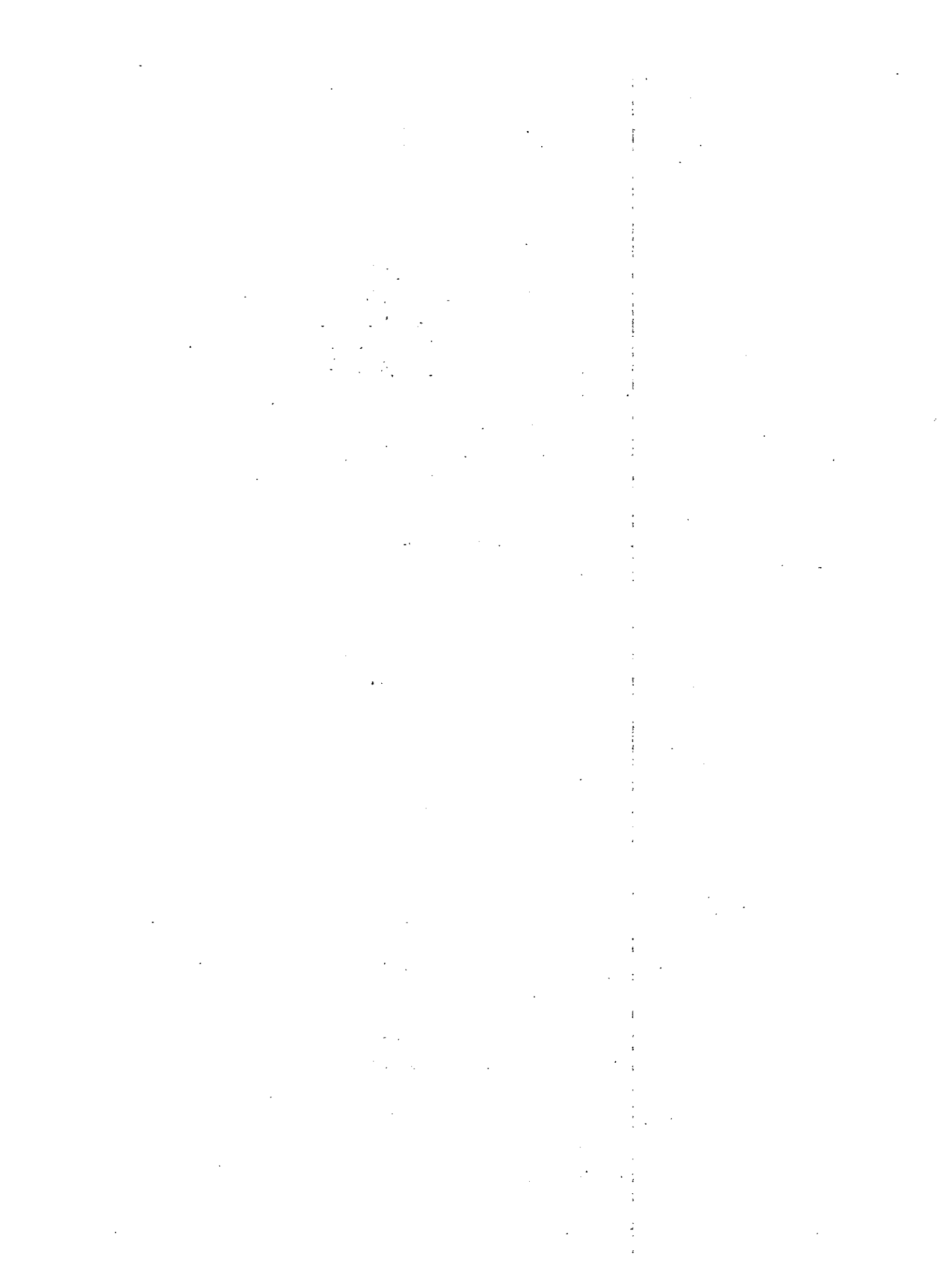

7

Using the NSxxx Setup Tool

This chapter describes how to set parameters and monitor basic operation of the NS310 Unit using the NSxxx setup tool.

7.1 Connection and Installation	7 - 2
7.1.1 Connecting the NS310 Unit	7 - 2
7.1.2 Software Installation	7 - 2
7.2 How to Use	7 - 3
7.2.1 Screen Configuration at Startup	7 - 3
7.2.2 Functions Configuration	7 - 5



7.1 Connection and Installation

7.1.1 Connecting the NS310 Unit

■ Connector Cables

Connect the CN11 port on the NS310 Unit and the RS-232C port on the personal computer using the following cable.

Model	Name
DE9404559	SGD Monitor Cable

■ Cable Wiring

Wire the cables as follows:

CN11 Pin number	Symbol	Details	Personal computer pin number (9 pins)
1	TXD (red)	Serial data output	2
2	RXD (white)	Serial data input	3
3	GND (black)	Ground	5
4	GND (black)	Ground	5

7.1.2 Software Installation

The following files are stored on the floppy disk for the NSxxx Setup Tool.

- NS_MMI.EXE (Execution module)
- ParmDef.CFG (Data files)
- RES_JPN.DLL (DLL in Japanese)
- RES_ENG.DLL (DLL in English)
- ParmDef(Jpn).CFG (Data files in Japanese)
- ParmDef(Eng).CFG (Data files in English)

Copy these files to any directory on the personal computer.

IMPORTANT

To use the files in Japanese, copy ParmDef(Jpn).CFG to ParmDef.CFG.

7.2 How to Use

7.2.1 Screen Configuration at Startup

Start the Setup Tool as follows:

1. Double-click the *NS_MMI.exe* file. The following communications setting screen will be displayed.

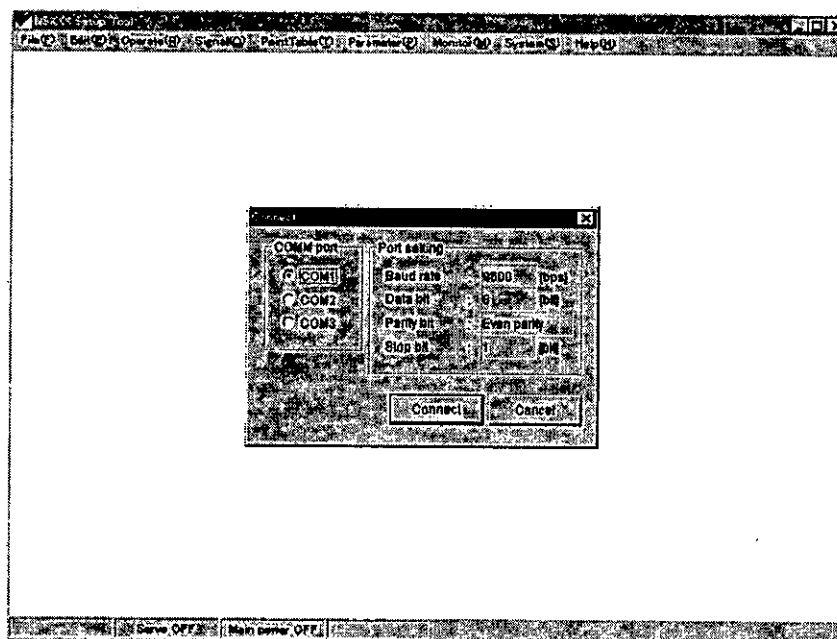

Figure 7.1 Communications setting screen

2. Perform one of the following operations.
 - If using any COM port other than COM1 on the personal computer, set the COMM PORT, then click the *Connect* Button.
 - To use COM1, just click the *Connect* Button directly.

Next, check the following:

- a) The communications power supply is being supplied via a DeviceNet cable to the NS310 Unit.
- b) The CN11 port on the NS310 Unit is connected to the personal computer via a communications cable.

The following startup screen will be displayed.

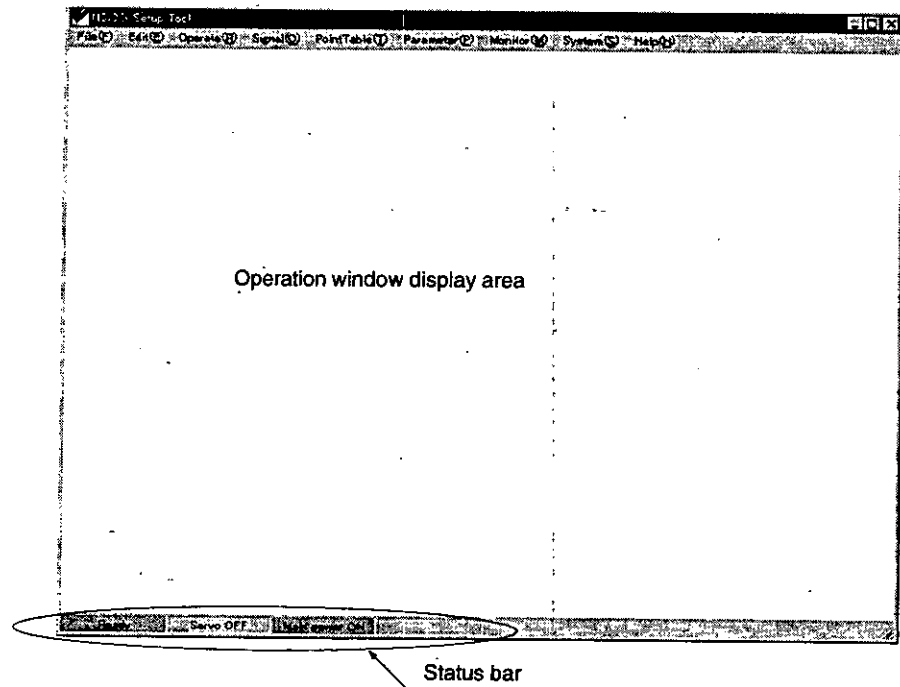

Figure 7.2 Startup screen

The following information is normally displayed on the status bar.

- **Ready**
Displays whether the NS310 Unit is ready.
If the Unit is ready, this icon will be lit green.
- **Servo ON/OFF**
Displays if the SGDH servo is ON or OFF.
If the servo is ON, this icon will be lit green.
- **Main Power ON**
Displays if the main power supply to the SGDH is ON.
If the main power supply is being supplied normally, this icon will be lit green.
- **Alarm**
Displays if an alarm has occurred in the NS310 Unit or SGDH.
If an alarm has occurred, this icon will be lit red.

7.2.2 Functions Configuration

The functions configuration of the Setup Tool is shown in the following diagram.

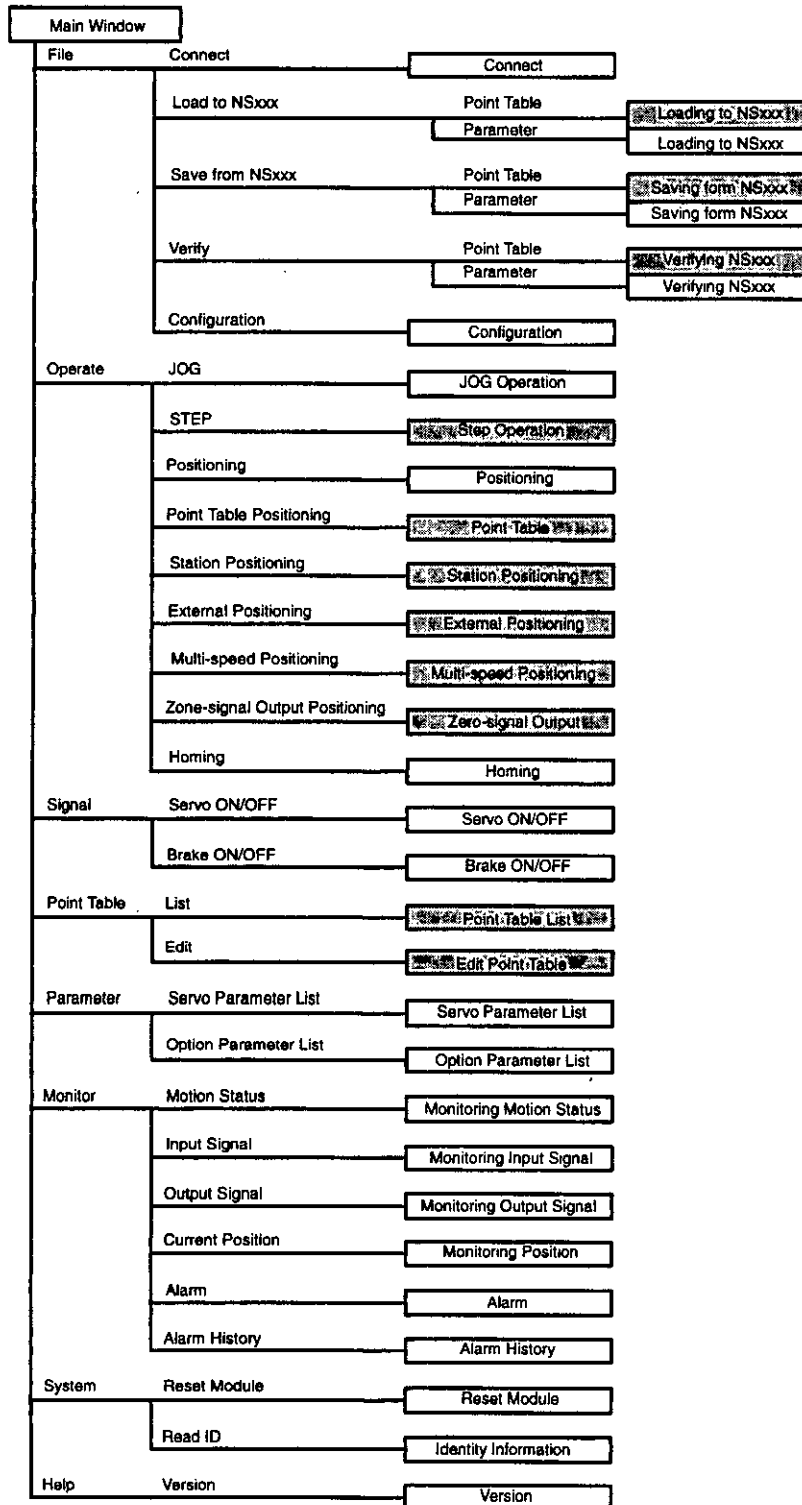

Note: The shaded areas show functions that cannot be used when an NS310 Unit is connected.

■ File Menu

1. Connect

Starts communications with the NS310 Unit.

2. Load to NSxxx

Loads to the NS310 Unit the parameter file stored in the personal computer.

3. Save from NSxxx

Saves to the personal computer the parameter data within the NS310 Unit.

4. Verify

Compares the parameter data stored in the personal computer and the parameter data in the NS310 Unit.

5. Configuration

Sets the units, etc.

■ Operate Menu

1. JOG

Performs continuous motor operation.

2. Positioning

Sets the target position, and then performs positioning.

3. Homing

Returns the servo to the home position.

■ Signal Menu

1. Servo ON/OFF

Turns ON and OFF the SGDh servo.

2. Brake ON/OFF

Turns ON and OFF the SGDh brake signal.

■ Parameter Menu

1. Servo Parameter List

Displays a table of SGDh parameters, which can be edited using the cursor.

2. Option Parameter List

Displays a table of NS310 Unit parameters, which can be edited using the cursor.

■ Monitor Menu

1. Motion Status

Displays the current execution status.

2. Input Signal

Displays the status of the external input signals connected to the CN1 port on the SGDh.

3. Output Signal

Displays the status of the external output signals connected to the CN1 port on the SGDh.

4. Current Position

Displays the current position of the servomotor in reference units.

5. Alarm

Displays any alarms that are currently occurring. You can also clear the alarms using this function.

6. Alarm History

Displays to a maximum of 10 the most recent alarms that have occur. You can also clear the alarm history using this function.

■ System Menu**1. Reset Module**

Resets the NS310 Unit and the SGDh.

When you reset the Unit, the parameters that have been changed will be stored in flash ROM.

2. Read ID

Displays version information for the NS310 Unit and SGDh, etc.

■ Help Menu**● Version**

Displays version information for the Setup Tool.



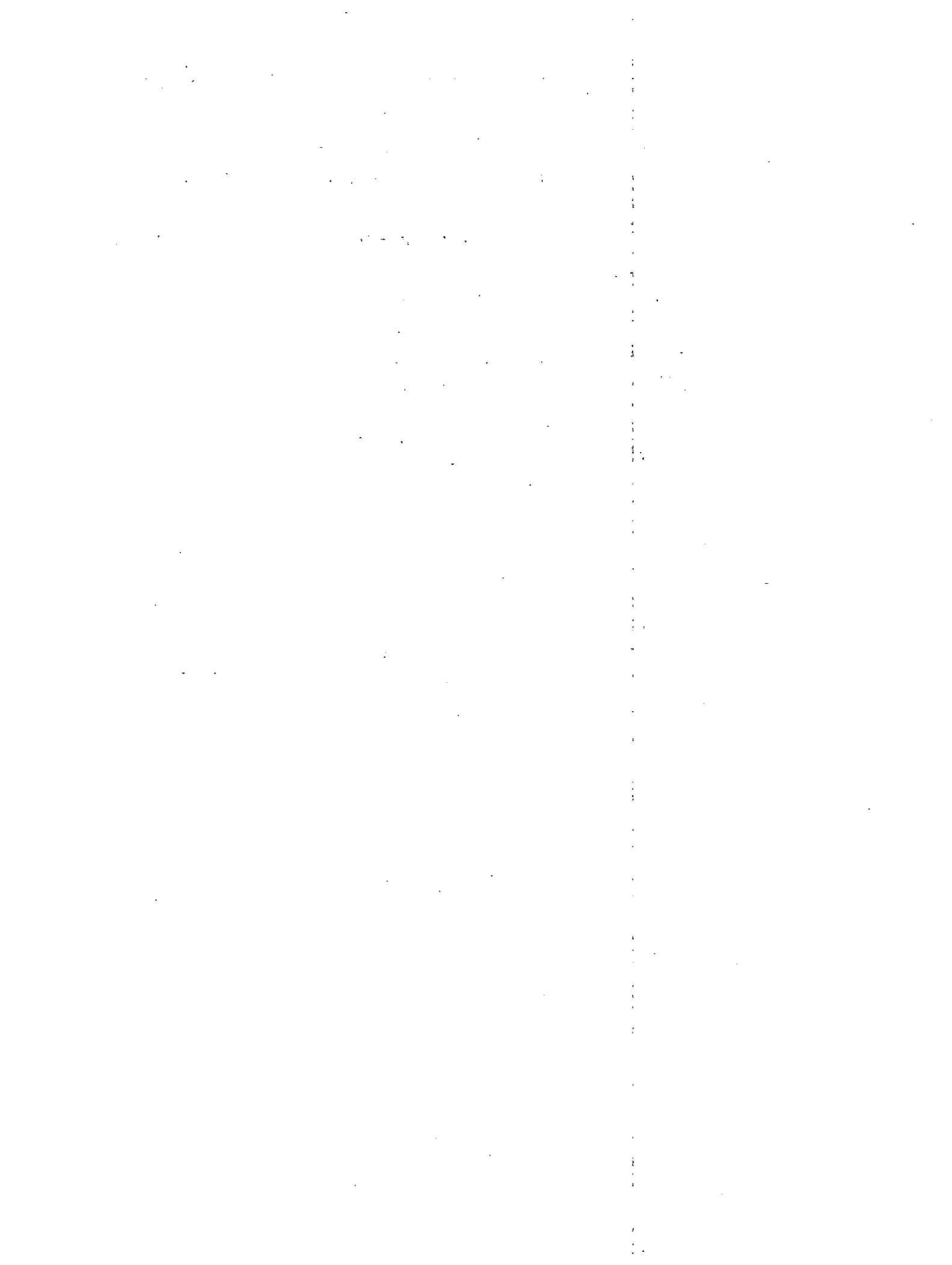

8

Ratings, Specifications, and Dimensions

This chapter provides the ratings, specifications, and dimensions of SGD H SERVOPACKs.

8.1 Ratings and Specifications	8 - 2
8.2 Dimensional Drawings	8 - 3
8.2.1 NS310 Unit	8 - 3



8.1 Ratings and Specifications

Item		Details
Applicable SERVOPACK		All SGDH-□□□E models
Installation Method		Mounted on the SGDH SERVOPACK
Basic Specifications	Power Supply Method	Supplied from the DeviceNet communications power supply.
	Power Consumption [W]	Communications power supply: 2.3 W at 24 V, 1.7 W at 11 V
	Consumption Current	Communications power supply: 96 mA at 24 V, 154 mA at 11 V
	External Dimensions [mm]	20 x 152 x 153 (W x H x D)
	Approx. Mass [kg] (lb)	0.3 (0.661)
DeviceNet Communications	Baud Rate Setting	Select from 125 Kbps, 250 Kbps, or 500 Kbps using a rotary switch.
	Node Address Setting	Select the address from 0 to 63 using the rotary switches.
Command Format	Operation Specifications	Positioning using DeviceNet communications
	Reference Input	DeviceNet communications Commands: Motion commands (position, speed), and reading and writing parameters
Position Control Functions	Acceleration/Deceleration Method	Linear first/second-step, asymmetric, exponential, S-curve
	Fully Closed Control	Not possible
Input Signals	Fixed Allocation to CN1 Connector	Forward/reverse run prohibited, home position signal, emergency stop signal
Internal Functions	Position Data Latch Function	Position data latching is possible using phase C and home position signals
	Protection	Parameters damage, parameter setting errors, communications errors, etc.
	LED Indicators	MS: Module Status NS: Network Status

8.2 Dimensional Drawings

Dimensional drawings of the NS310 Unit and SERVOPACKs are shown below.

8.2.1 NS310 Unit

Dimensions of the NS310 Unit are shown below.

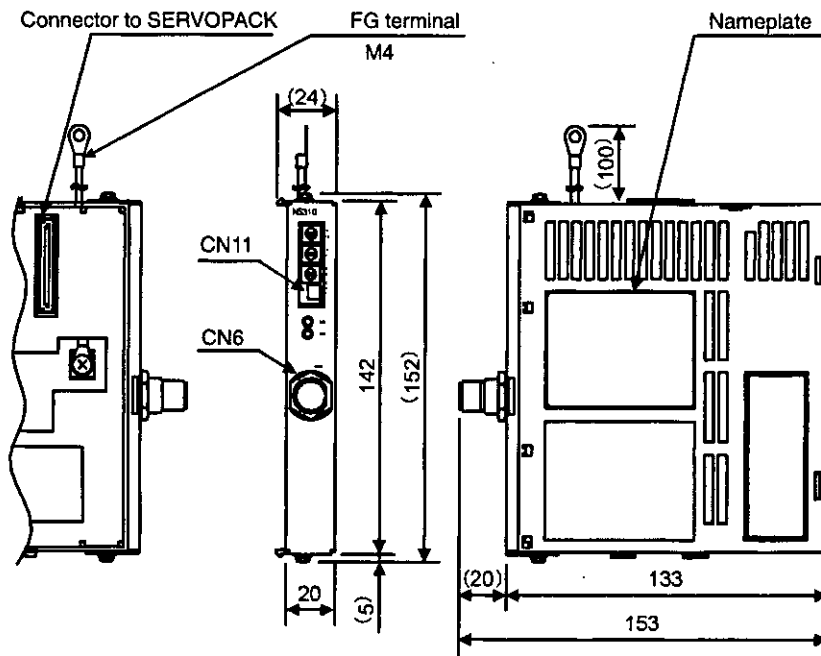

Approx. mass: 0.3 kg (0.661 lb)

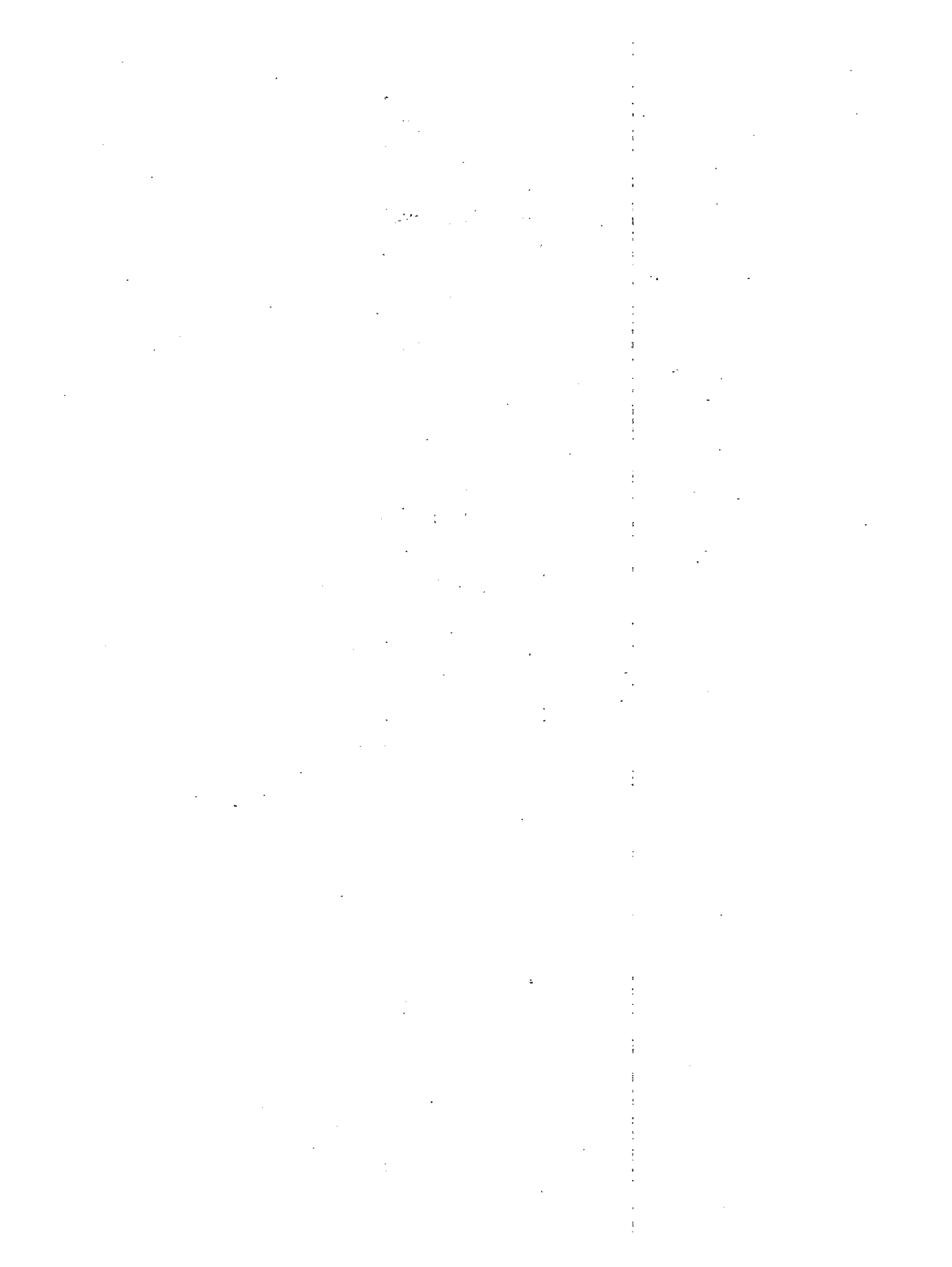

9

Troubleshooting

This chapter describes troubleshooting procedures for problems which cause an alarm indication and for problems which result in no alarm indication.

9.1 Troubleshooting Problems with Alarm Displays	9 - 2
9.2 Troubleshooting Problems with No Alarm Display	9 - 19
9.3 Alarm Display Table	9 - 21
9.4 Warning Displays	9 - 24



9.1 Troubleshooting Problems with Alarm Displays

Problems that occur in the Servodrives are displayed on the panel operator as "A.□□" or "CPF-□□". "A.--", however, does not indicate an alarm. Refer to the following sections to identify the cause of an alarm and the action to be taken.

Contact your Yaskawa representative if the problem cannot be solved by the described procedures.

■ A.02

A.02: Parameter Breakdown

Display and Outputs

Alarm Outputs			
Alarm Code Outputs			ALM Output
ALO1	ALO2	ALO3	
OFF	OFF	OFF	OFF

Note OFF: Output transistor is OFF (alarm state).

Status and Remedy for Alarm

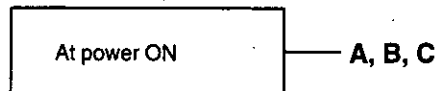

Cause		Remedy
A	Power turned OFF during parameter write. Alarm occurred at next power ON.	<ul style="list-style-type: none"> Initialize parameters using Fn005 and reinput user settings. Replace the SERVOPACK.
B	Circuit board (IPWB) is defective.	Replace the SERVOPACK.
C	NS310 Unit is defective.	Replace the NS310 Unit.

■ A.03

A.03: Main Circuit Detector Error

Display and Outputs

Alarm Outputs			
Alarm Code Outputs			ALM Output
ALO1	ALO2	ALO3	
OFF	OFF	OFF	OFF

Note OFF: Output transistor is OFF (alarm state).

the Status and Remedy for Alarm



Cause		Remedy
A	Circuit board (1PWB or 2PWB) defective.	Replace the SERVOPACK.

■ **A.04**

A.04: Parameter Setting Error

Display and Outputs

Alarm Outputs			
Alarm Code Outputs			ALM Output
ALO1	ALO2	ALO3	
OFF	OFF	OFF	OFF

Note OFF: Output transistor is OFF (alarm state)

Status and Remedy for Alarm



Cause		Remedy
A	An out-of-range parameter was previously set or loaded.	<ul style="list-style-type: none"> • Reset all parameters in range. • Otherwise, re-load correct parameter.
B	Circuit board (1PWB) is defective.	Replace the SERVOPACK.
C	NS310 Unit is defective.	Replace the NS310 Unit.

■ **A.05**

A.05: Combination Error

Display and Outputs

Alarm Outputs			
Alarm Code Outputs			ALM Output
ALO1	ALO2	ALO3	
OFF	OFF	OFF	OFF

Note OFF: Output transistor is OFF (alarm state).

Status and Remedy for Alarm

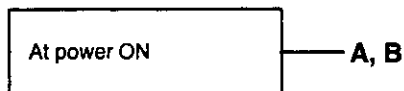

Cause		Remedy
A	The range of servomotor capacities that can be combined has been exceeded.	Replace the servomotor so that a suitable combination is achieved.
B	Encoder parameters have not been written properly.	Replace the servomotor.

■ **A.10**

A.10: Overcurrent or Heat Sink Overheated

Display and Outputs

Alarm Outputs			
Alarm Code Outputs			ALM Output
ALO1	ALO2	ALO3	
ON	OFF	OFF	OFF

Note OFF: Output transistor is OFF (alarm state). ON: Output transistor is ON.

Status and Remedy for Alarm

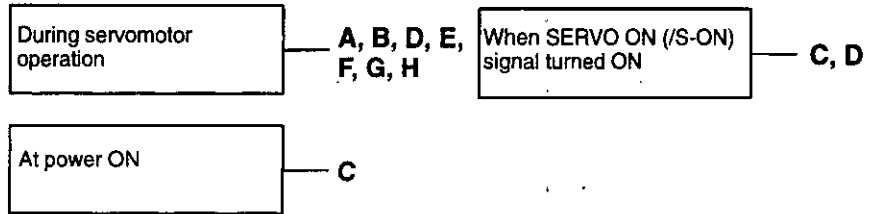

Cause		Remedy
A	Wiring shorted between SERVOPACK and servomotor.	Check and correct wiring.
B	Servomotor U, V, or W phase shorted.	Replace the servomotor.
C	<ul style="list-style-type: none"> • Circuit board (1PWB) defective. • Power transistor defective. 	Replace the SERVOPACK.
D	Current feedback circuit, power transistor, DB circuit, or circuit board defective.	Replace the SERVOPACK.
E	The ambient temperature of the SERVO-PACK exceeded 55°C.	Alter conditions so that the ambient temperature goes below 55°C.
F	The air flow around the heat sink is bad.	Follow the installation method and provide sufficient space as specified.
G	Fan stopped.	Replace the SERVOPACK.
H	SERVOPACK is operating under an overload.	Reduce the load.

Note E to H can occur with a SERVOPACK with a capacity of all models (400 V) and 1.5 kW to 5 kW (200 V).

■ **A.30**

A.30: Regenerative Error Detected

Display and Outputs

Alarm Outputs			
Alarm Code Outputs			ALM Output
ALO1	ALO2	ALO3	
ON	ON	OFF	OFF

Note OFF: Output transistor is OFF (alarm state). ON:Output transistor is ON.

Status and Remedy for Alarm

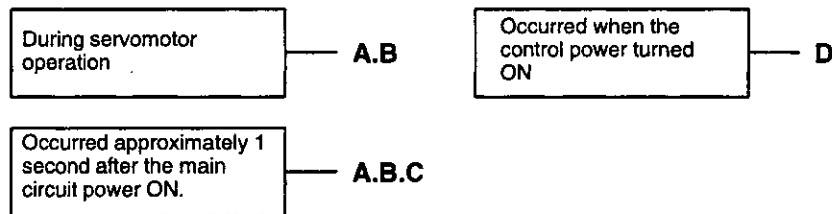

Cause		Remedy
A	Regenerative transistor is abnormal.	Replace the SERVOPACK.
B	Disconnection of the regenerative resistor.	Replace the SERVOPACK or regenerative resistor.
C	Regenerative Unit disconnected (for an external regenerative resistor).	Check wiring of the external regenerative resistor.
D	SERVOPACK is defective.	Replace the SERVOPACK.

■ **A.32**

A.32: Regenerative Overload

Display and Outputs

Alarm Outputs			
Alarm Code Outputs			ALM Output
ALO1	ALO2	ALO3	
ON	ON	OFF	OFF

Note OFF: Output transistor is OFF (alarm state). ON:Output transistor is ON.

Status and Remedy for Alarm

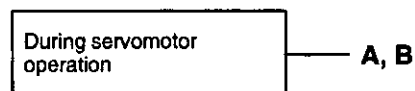

Cause		Remedy
A	Regenerative power exceeds the allowable value.	Use an external regenerative resistor that matches the regenerative power capacity.
B	Alarm occurs although an external regenerative resistor is used and the temperature rise of the regenerative resistor is small.	Correct the parameter Pn600.

■ **A.40**

A.40: Main Circuit DC Voltage Error Detected: Overvoltage

Display and Outputs

Alarm Outputs			
Alarm Code Outputs			ALM Output
ALO1	ALO2	ALO3	
OFF	OFF	ON	OFF

Note OFF: Output transistor is OFF (alarm state). ON: Output transistor is ON.

Status and Remedy for Alarm

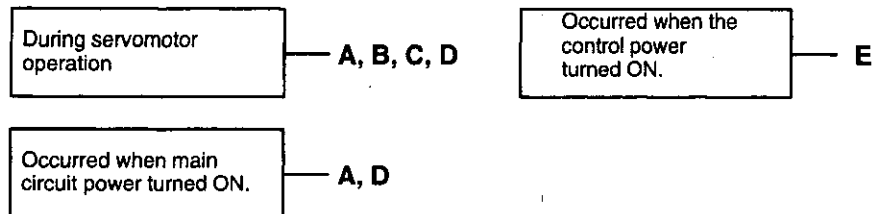

Cause		Remedy
A	The power supply voltage is not within the range of specifications.	Check power supply.
B	Load exceeds capacity of the Regenerative Unit.	Check specifications of load moment of inertia and overhanging load.
C	Regenerative transistor is abnormal.	Replace the SERVOPACK.
D	Rectifying diode is defective.	
E	SERVOPACK is defective.	

■ **A.41**

A.41: Main Circuit DC Voltage Error Detected: Undervoltage

Display and Outputs

Alarm Outputs			
Alarm Code Outputs			ALM Output
ALO1	ALO2	ALO3	
OFF	OFF	ON	OFF

Note OFF: Output transistor is OFF (alarm state). ON:Output transistor is ON.

Status and Remedy for Alarm

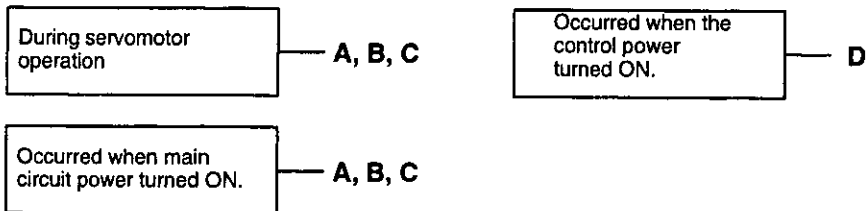

Cause		Remedy
A	The power supply voltage is not within the range of specifications.	Check power supply voltage.
B	Fuse blown.	Replace the SERVOPACK.
C	Rectifying diode is defective.	
D	SERVOPACK is defective.	

■ **A.51**

A.51: Overspeed

Display and Outputs

Alarm Outputs			
Alarm Code Outputs			ALM Output
ALO1	ALO2	ALO3	
ON	OFF	ON	OFF

Note OFF: Output transistor is OFF (alarm state). ON:Output transistor is ON.

Status and Remedy for Alarm

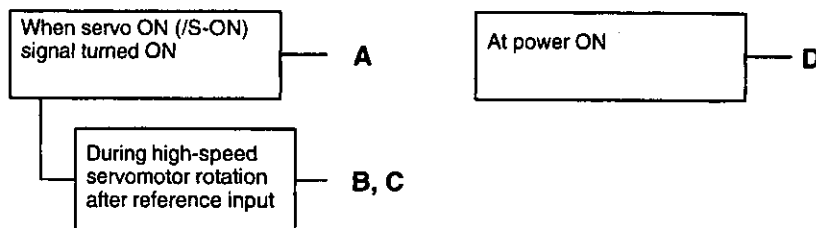

Cause		Remedy
A	Servomotor wiring incorrect.	Check and correct wiring. (Check for phase U, V, and W wiring errors.)
B	Position or speed reference input is too large.	Lower the reference input values.
C	Incorrect reference input gain settings.	Check and correct parameter settings.
D	Circuit board (1PWB) is defective.	Replace the SERVOPACK.

■ **A.71**

A.71: Overload: High Load

The alarm output, status, and remedy for A.71 are the same as for A.72.

■ **A.72**

A.72: Overload: Low Load

Display and Outputs

Alarm Outputs			
Alarm Code Outputs			ALM Output
ALO1	ALO2	ALO3	
ON	ON	ON	OFF

Note OFF: Output transistor is OFF (alarm state). ON: Output transistor is ON.

Status and Remedy for Alarm

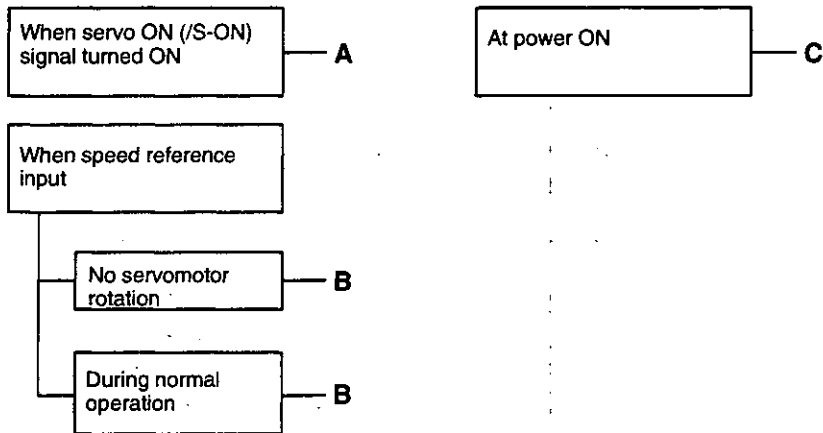

Cause		Remedy
A	Servomotor wiring is incorrect or disconnected.	Check wiring and connectors at servomotor.
B	Load greatly exceeds rated torque.	Reduce load torque and moment of inertia. Otherwise, replace with larger capacity servomotor.
C	Circuit board (1PWB) is defective.	Replace the SERVOPACK.

■ A.73

A.73: Dynamic Brake Overload

Display and Outputs

Alarm Outputs			
Alarm Code Outputs			ALM Output
ALO1	ALO2	ALO3	
ON	ON	ON	OFF

Note OFF: Output transistor is OFF (alarm state). ON:Output transistor is ON.

Status and Remedy for Alarm

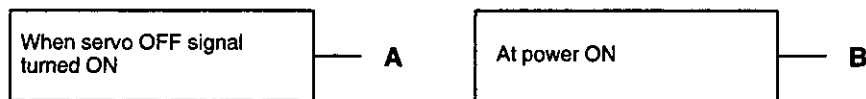

Cause		Remedy
A	The product of the square of rotational motor speed and the combined inertia of the motor and load (rotation energy) exceeds the capacity of the dynamic brake resistor built into the SERVOPACK.	<ul style="list-style-type: none"> • Lower the rotational speed. • Lower the load moment of inertia. • Minimize the use of the dynamic brake.
B	Circuit board (1PWB) is defective.	Replace the SERVOPACK.

■ A.74

A.74: Overload of Surge Current Limit Resistor

Display and Outputs

Alarm Outputs			
Alarm Code Outputs			ALM Output
ALO1	ALO2	ALO3	
ON	ON	ON	OFF

Note OFF: Output transistor is OFF (alarm state). ON:Output transistor is ON.

Status and Remedy for Alarm



Cause		Remedy
A	Frequently turning the main circuit power ON/OFF.	Do not repeatedly turn ON/OFF the main circuit power.
B	Circuit board (1PWB) is defective.	Replace the SERVOPACK.

■ **A.7A**

A.7A: Heat Sink Overheated

Display and Outputs

Alarm Outputs			
Alarm Code Outputs			ALM Output
ALO1	ALO2	ALO3	
ON	ON	ON	OFF

Note OFF: Output transistor is OFF (alarm state); ON:Output transistor is ON.

Status and Remedy for Alarm

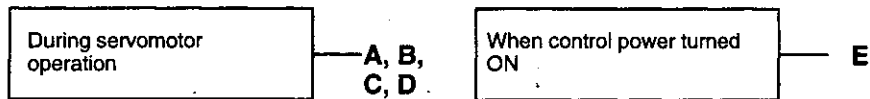

Cause		Remedy
A	The ambient temperature of the SERVO-PACK exceeds 55°C.	Alter conditions so that the ambient temperature goes below 55°C.
B	The air flow around the heat sink is bad.	Follow installation methods and provide sufficient space as specified.
C	Fan stopped.	Replace the SERVOPACK.
D	SERVOPACK is operating under overload.	Reduce the load.
E	SERVOPACK is defective.	Replace the SERVOPACK.

Note This alarm display tends to occur only with a SERVOPACK of 30 W to 1000 W.

■ **A.81**

A.81: Absolute Encoder Backup Error

Display and Outputs

Alarm Outputs			
Alarm Code Outputs			ALM Output
ALO1	ALO2	ALO3	
OFF	OFF	OFF	OFF

Note OFF: Output transistor is OFF (alarm state).

Status and Remedy for Alarm

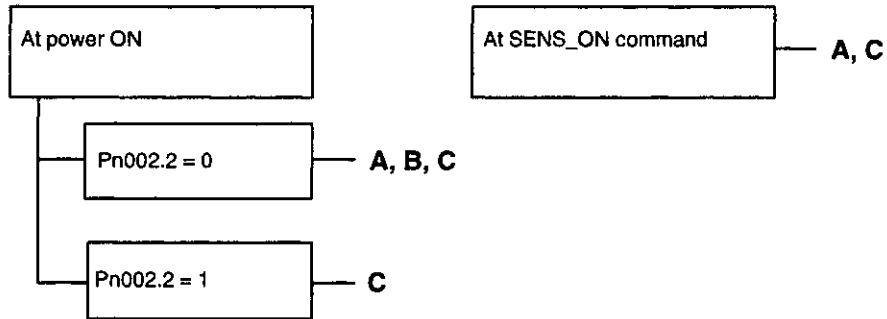

Cause		Remedy
A	The following power supplies to the absolute encoder all failed: <ul style="list-style-type: none"> +5 V supply (supplied from SERVO-PACK) Battery power 	Follow absolute encoder setup procedure.
B	Absolute encoder malfunctioned.	Replace the servomotor.
C	Circuit board (1PWB) is defective.	Replace the SERVOPACK.

■ A.82

A.82: Encoder Checksum Error

Display and Outputs

Alarm Outputs			
Alarm Code Outputs			ALM Output
ALO1	ALO2	ALO3	
OFF	OFF	OFF	OFF

Note OFF: Output transistor is OFF (alarm state).

Status and Remedy for Alarm

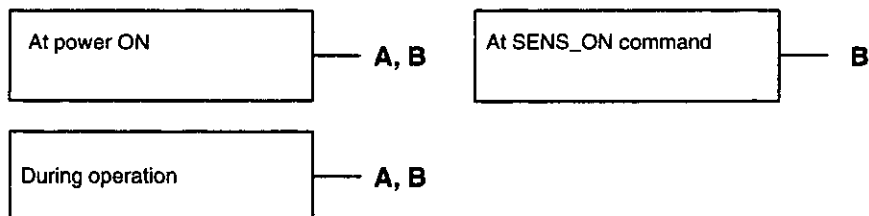

Cause		Remedy
A	Error during encoder memory check	<ul style="list-style-type: none"> Follow absolute encoder setup procedure. Replace the servomotor if the error occurs frequently.
B	Circuit board (1PWB) is defective.	Replace the SERVOPACK.



■ **A.83**

A.83: Absolute Encoder Battery Error

Display and Outputs

Alarm Outputs			
Alarm Code Outputs			ALM Output
ALO1	ALO2	ALO3	
OFF	OFF	OFF	OFF

Note OFF: -Output transistor is OFF (alarm state).

Status and Remedy for Alarm

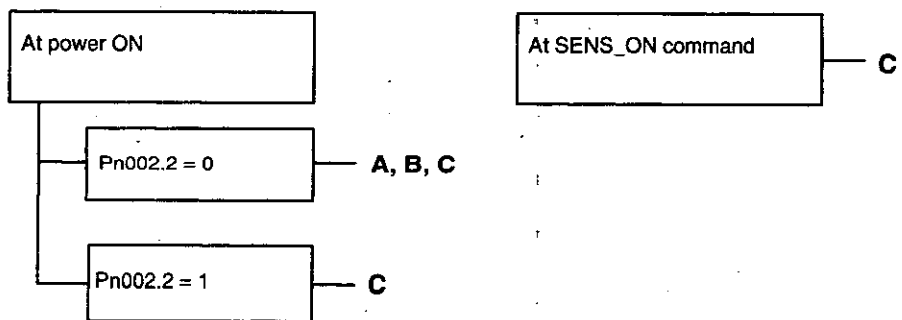

Cause		Remedy
A	<ul style="list-style-type: none"> Battery is not connected. Battery connection is defective. 	Check and correct battery connection.
B	Battery voltage below specified value. Specified value: 2.7 V	Install a new battery while the control power to SERVOPACK is ON. After replacement, turn ON the power again.
C	Circuit board (1PWB) is defective.	Replace the SERVOPACK.

Note No alarm will occur at the SERVOPACK if the battery error occurs during operation.

■ **A.84**

A.84: Absolute Encoder Data Error

Display and Outputs

Alarm Outputs			
Alarm Code Outputs			ALM Output
ALO1	ALO2	ALO3	
OFF	OFF	OFF	OFF

Note OFF: Output transistor is OFF (alarm state).

Status and Remedy for Alarm



Cause		Remedy
A	Encoder is defective.	Replace the servomotor if the error occurs frequently.
B	Operational error in encoder caused by external noise.	Check and correct wiring around the encoder as follows: <ul style="list-style-type: none"> • Grounding of the servomotor • Separation between the encoder cable and the servomotor power cable • Insertion of toroidal cores onto cables

■ **A.85**

A.85: Absolute Encoder Overspeed

Display and Outputs

Alarm Outputs			
Alarm Code Outputs			ALM Output
ALO1	ALO2	ALO3	
OFF	OFF	OFF	OFF

Note OFF: Output transistor is OFF (alarm state).

Status and Remedy for Alarm



Cause		Remedy
A	Absolute encoder turned ON at a speed exceeding 200 min ⁻¹ .	Turn ON power supply again with the servomotor stopped.
B	Circuit board (1PWB) is defective.	Replace the SERVOPACK.



■ **A.86**

A.86: Encoder Overheated

Display and Outputs

Alarm Outputs			
Alarm Code Outputs			ALM Output
ALO1	ALO2	ALO3	
OFF	OFF	OFF	OFF

Note OFF: Output transistor is OFF (alarm state).

Status and Remedy for Alarm

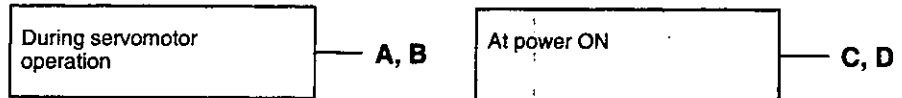

Cause		Remedy
A	The ambient temperature of the servomotor is high.	Alter conditions so that the ambient temperature goes below 40°C.
B	Servomotor is operating under overload.	Reduce the load.
C	Circuit board (1PWB) is defective.	Replace the SERVOPACK.
D	Encoder is defective.	Replace the servomotor.

■ **A.94**

A.94: Parameter Setting Error

Display and Outputs

Alarm Outputs			
Alarm Code Outputs			ALM Output
ALO1	ALO2	ALO3	
ON	ON	OFF	ON

Note OFF: Output transistor is OFF (alarm state). ON: Output transistor is ON.

Status and Remedy for Alarm

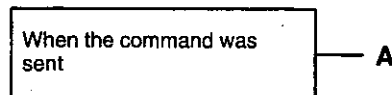

Cause		Remedy
A	A value outside the DeviceNet communications setting range was set.	Reset correctly.

■ A.95

A.95: Command Error

Display and Outputs

Alarm Outputs			
Alarm Code Outputs			ALM Output
ALO1	ALO2	ALO3	
OFF	ON	OFF	ON

Note OFF: Output transistor is OFF (alarm state). ON: Output transistor is ON.

Status and Remedy for Alarm

When the command was sent	A, B
---------------------------	------

Cause		Remedy
A	Presently unable to receive the command that has been sent.	Adjust conditions to match the command. Refer to the specifications for each command.
B	Unsupported command.	Do not send unsupported commands.

■ A.96

A.96: DeviceNet Communications Warning

Display and Outputs

Alarm Outputs			
Alarm Code Outputs			ALM Output
ALO1	ALO2	ALO3	
ON	OFF	OFF	ON

Note OFF: Output transistor is OFF (alarm state). ON: Output transistor is ON.

Status and Remedy for Alarm

During DeviceNet communications	A, B
---------------------------------	------

Cause		Remedy
A	Contact between the cable and the connector is faulty.	Correct the connector wiring.
B	Malfunction due to noise.	Take noise prevention measures.

■ **A.97**

A.97: No Control Power Supply to SGDH

Display and Outputs

Alarm Outputs			
Alarm Code Outputs			ALM Output
ALO1	ALO2	ALO3	
OFF	OFF	OFF	ON

Note OFF: Output transistor is OFF (alarm state). ON: Output transistor is ON.

Status and Remedy for Alarm

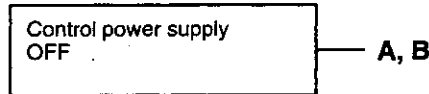

Cause		Remedy
A	Contact between the cable and the connector is faulty.	Correct the connector wiring.
B	Power Supply Unit is defective.	Check the Power Supply Unit.

■ **A.98**

A.98: Main Power OFF

Display and Outputs

Alarm Outputs			
Alarm Code Outputs			ALM Output
ALO1	ALO2	ALO3	
ON	ON	ON	ON

Note OFF: Output transistor is OFF (alarm state). ON: Output transistor is ON.

Status and Remedy for Alarm

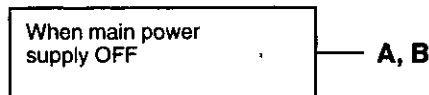

Cause		Remedy
A	Contact between the cable and the connector is faulty.	Correct the connector wiring.
B	Power Supply Unit is defective.	Check the Power Supply Unit.

■ A.b6

A.b6: Communications LSI Error

Display and Outputs

Alarm Outputs			
Alarm Code Outputs			ALM Output
ALO1	ALO2	ALO3	
OFF	OFF	OFF	OFF

Note OFF: Output transistor is OFF (alarm state).

Status and Remedy for Alarm



Cause		Remedy
A	NS310 Unit is defective.	Replace the NS310 Unit.

■ A.CC

A.CC: Multi-turn Limit Mismatch

Display and Outputs

Alarm Outputs			
Alarm Code Outputs			ALM Output
ALO1	ALO2	ALO3	
ON	OFF	ON	OFF

Note OFF: Output transistor is OFF (alarm state). ON: Output transistor is ON.

Status and Remedy for Alarm



Cause		Remedy
A	The setting of the Multi-turn Limit Setting (Pn205) parameter in the SERVOPACK is incorrect.	Change parameter Pn205.
B	The multi-turn limit has not been set in the encoder.	Check that the Multi-turn Limit Setting (Pn205) parameter in the SERVOPACK is correct, and then execute the encoder multi-turn limit setting change (Fn013) when a Multi-turn Limit Mismatch (A.CC) occurs.

■ **A.d0**

A.d0: Position Error Pulse Overflow

Display and Outputs

Alarm Outputs			
Alarm Code Outputs			ALM Output
ALO1	ALO2	ALO3	
ON	ON	OFF	OFF

Note OFF: Output transistor is OFF (alarm state). ON: Output transistor is ON.

Status and Remedy for Alarm

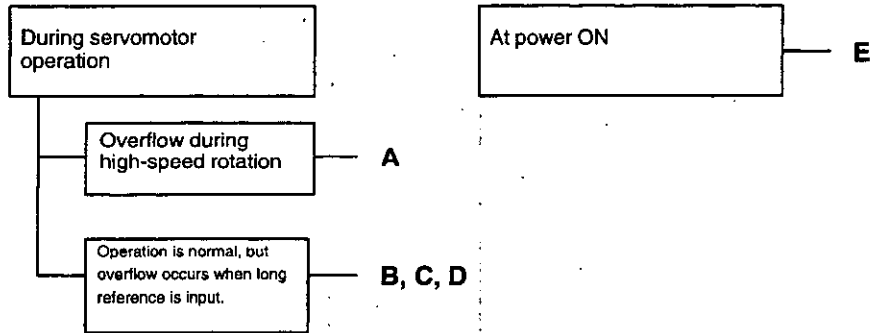

Cause		Remedy
A	Servomotor wiring is incorrect or connection is poor.	Correct wiring at servomotor.
B	SERVOPACK was not correctly adjusted.	Increase speed loop gain (Pn100) and position loop gain (Pn102).
C	Motor load was excessive.	Reduce the load torque or moment of inertia. If problem not corrected, replace with a motor with larger capacity.
D	Position reference is too high.	<ul style="list-style-type: none"> • Reduce the acceleration/deceleration rate. • Correct electronic gear ratio.

■ A.E0

A.E0: No NS310 Unit

Display and Outputs

Alarm Outputs			
Alarm Code Outputs			ALM Output
ALO1	ALO2	ALO3	
OFF	ON	ON	OFF

Note OFF: Output transistor is OFF (alarm state). ON: Output transistor is ON.

Status and Remedy for Alarm

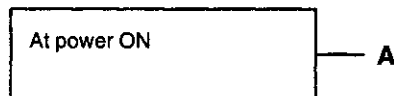

Cause		Remedy
A	NS310 Unit is defective.	Replace the NS310 Unit.

■ A.E1

A.E1: NS310 Unit Timeout

Display and Outputs

Alarm Outputs			
Alarm Code Outputs			ALM Output
ALO1	ALO2	ALO3	
OFF	ON	ON	OFF

Note OFF: Output transistor is OFF (alarm state). ON: Output transistor is ON.

Status and Remedy for Alarm

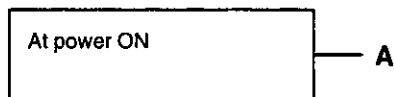

Cause		Remedy
A	NS310 Unit is defective.	Replace the NS310 Unit.

■ **A.E2**

A.E2: Watchdog Counter Error of NS310 Unit

Display and Outputs

Alarm Outputs			
Alarm Code Outputs			ALM Output
ALO1	ALO2	ALO3	
OFF	ON	ON	OFF

Note OFF: Output transistor is OFF (alarm state). ON: Output transistor is ON.

Status and Remedy for Alarm



Cause		Remedy
A	NS310 Unit is defective.	Replace the NS310 Unit.
B	DeviceNet communications interrupted.	Turn ON the power again.

■ **A.E6**

A.E6: DeviceNet Duplicate MAC ID Error

Display and Outputs

Alarm Outputs			
Alarm Code Outputs			ALM Output
ALO1	ALO2	ALO3	
OFF	ON	ON	OFF

Note OFF: Output transistor is OFF (alarm state). ON: Output transistor is ON.

Status and Remedy for Alarm

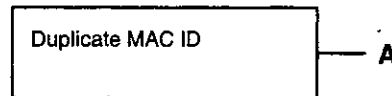

Cause		Remedy
A	Duplicate node address	Check the node addresses of all Units on the DeviceNet network.

■ A.E7

A.E7: NS310 Unit Detection Error when SGDH power is ON

A.E7 occurs when the SGDH is used without the NS310 Unit after it has been used with the NS310 Unit.

Display and Outputs

Alarm Outputs			
Alarm Code Outputs			ALM Output
ALO1	ALO2	ALO3	
OFF	ON	ON	OFF

Note OFF: Output transistor is OFF (alarm state). ON: Output transistor is ON.

Status and Remedy for Alarm

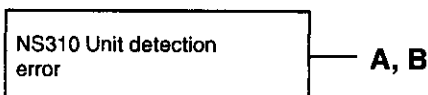

Cause		Remedy
A	The NS310 Unit is not mounted properly.	Check that NS310 Unit mounted correctly.
B	The NS310 Unit is not mounted.	Execute Fn014 from Digital Operator.

■ A.E8

A.E8: Rotary Switch Setting Error on Unit Front Panel

Display and Outputs

Alarm Outputs			
Alarm Code Outputs			ALM Output
ALO1	ALO2	ALO3	
OFF	ON	ON	OFF

Note OFF: Output transistor is OFF (alarm state). ON: Output transistor is ON.

Status and Remedy for Alarm

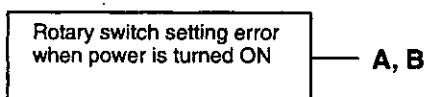

Cause		Remedy
A	Baud rate setting is incorrect.	Be sure the setting is between 0 and 2.
B	Node address setting is incorrect.	Be sure the setting is between 0 and 63.

■ **A.E9**

A.E9: DeviceNet BUS-OFF Error

Display and Outputs

Alarm Outputs			
Alarm Code Outputs			ALM Output
ALO1	ALO2	ALO3	
OFF	ON	ON	OFF

Note OFF: Output transistor is OFF (alarm state). ON: Output transistor is ON.

Status and Remedy for Alarm



Cause		Remedy
A	There is no terminating resistance in the network.	Check that a terminator is mounted to both ends of the DeviceNet network.
B	There is noise in the network wiring.	Separate the network wiring from the power supply circuit.
C	The baud rate is incorrect.	Check the communications settings of the rotary switches mounted on the front panel of the Unit.

■ **A.EA**

A.EA: SGD H System Error

Display and Outputs

Alarm Outputs			
Alarm Code Outputs			ALM Output
ALO1	ALO2	ALO3	
OFF	ON	ON	OFF

Note OFF: Output transistor is OFF (alarm state). ON: Output transistor is ON.

Status and Remedy for Alarm

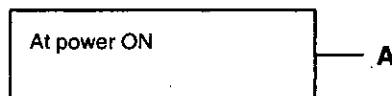

Cause		Remedy
A	SERVOPACK is defective.	Replace the SERVOPACK.

■ A.EB

A.EB: Initial Handshake Error

Display and Outputs

Alarm Outputs			
Alarm Code Outputs			ALM Output
ALO1	ALO2	ALO3	
OFF	ON	ON	OFF

Note OFF: Output transistor is OFF (alarm state). ON: Output transistor is ON.

Status and Remedy for Alarm



Cause		Remedy
A	SERVOPACK is defective.	Replace the SERVOPACK.

■ A.EC

A.EC: Watchdog Counter Error of NS310 Unit

Display and Outputs

Alarm Outputs			
Alarm Code Outputs			ALM Output
ALO1	ALO2	ALO3	
OFF	ON	ON	OFF

Note OFF: Output transistor is OFF (alarm state). ON: Output transistor is ON.

Status and Remedy for Alarm



Cause		Remedy
A	SERVOPACK is defective.	Replace the SERVOPACK.

9.2 Troubleshooting Problems with No Alarm Display

Refer to the tables below to identify the cause of a problem which causes no alarm display and take the remedy described.

Turn OFF the servo system power supply before commencing the shaded procedures.

Contact your Yaskawa representative if the problem cannot be solved by the described procedures.

Table 9.1 Troubleshooting Table No Alarm Display

Symptom	Cause	Inspection	Remedy
Servomotor Does Not Start	Power is not connected.	Check voltage between power supply terminals.	Correct the power circuit.
	Loose connection	Check terminals of connectors (CN1, CN2).	Tighten any loose parts.
	Connector (CN1) external wiring is incorrect.	Check connector (CN1) external wiring.	Refer to connection diagram and correct wiring.
	Servomotor or encoder wiring is disconnected.	---	Reconnect wiring.
	Overloaded	Run under no load.	Reduce load or replace with larger capacity servomotor.
	Encoder type differs from parameter setting.	Check the type of encoder being used.	Set parameter Pn002.2 to the encoder type being used.
	P-OT and N-OT inputs are turned OFF.	Refer to 6.3 Settings According to Host Controller.	Turn P-OT and N-OT input signals ON.
Servomotor Does Not Run	Motion commands have not been sent.	Check using DeviceNet communications.	Send the motion commands.
	SV_ON command has not been sent.		Send the SV_ON command.
Servomotor Moves Instantaneously, then Stops	Servomotor or encoder wiring is incorrect.	---	Refer to Chapter 3 Connectors and correct wiring.
Servomotor Speed Unstable	Wiring connection to motor is defective.	Check connection of power lead (phases U, V, and W) and encoder connectors.	Tighten any loose terminals or connectors.
Servomotor Vibrates at Approximately 200 to 400 Hz.	Speed loop gain is too high.	---	Reduce speed loop gain (Pn100) preset value.
High Rotation Speed Overshoot on Starting and Stopping	Speed loop gain is too high.	---	Reduce speed loop gain (Pn100) preset value. Increase integration time constant (Pn101).
	Speed loop gain is too low compared to position loop gain.	---	Increase speed loop gain (Pn100). Reduce the integration time constant (Pn101).

Symptom	Cause	Inspection	Remedy
Servomotor Overheated	Ambient temperature is too high.	Measure servomotor ambient temperature.	Reduce ambient temperature to 40°C max.
	Servomotor surface is dirty.	Visually check.	Clean dust and oil from motor surface.
	Overloaded	Run under no load.	Reduce load or replace with larger capacity servomotor.
Abnormal Noise	Mechanical mounting is incorrect.	Check servomotor mounting screws.	Tighten mounting screws.
		Check couplings are centered.	Center coupling.
		Check coupling balance.	Balance coupling.
	Bearing is defective.	Check noise and vibration near bearing.	Consult your Yaskawa representative if defective.
	Machine causing vibrations	Check foreign object intrusion, damage or deformation of sliding parts of machine.	Consult with machine manufacturer.



9.3 Alarm Display Table

A summary of alarm displays and alarm code outputs is given in the following table.

Table 9.2 Alarm Display Table

Alarm Display	Alarm Code Outputs			ALM Output	Alarm Name	Description
	ALO1	ALO2	ALO3			
A.02	OFF	OFF	OFF	OFF	Parameter Breakdown* ²	EEPROM data of SERVOPACK is abnormal.
A.03					Main Circuit Encoder Error	Detection data for power circuit is abnormal.
A.04					Parameter Setting Error* ²	The parameter setting is outside the allowable setting range.
A.05					Combination Error	SERVOPACK and servomotor capacities do no match each other.
A.10	ON	OFF	OFF	OFF	Overcurrent or Heat Sink Overheat* ²	An overcurrent flowed through the IGBT. Heat sink of SERVOPACK was overheated.
A.30	ON	ON	OFF	OFF	Regeneration Error	<ul style="list-style-type: none"> • Regenerative circuit is defective. • Regenerative resistor is defective.
A.32					Regenerative Overload	Regenerative energy exceeds regenerative resistor capacity.
A.40	OFF	OFF	ON	OFF	Overvoltage* ³	Main circuit DC voltage is excessively high.
A.41					Undervoltage* ³	Main circuit DC voltage is excessively low.
A.51	ON	OFF	ON	OFF	Overspeed	Rotational speed of the motor is excessively high.
A.71	ON	ON	ON	OFF	Overload for Instantaneous Maximum Load	The motor was operating for several seconds to several tens of seconds under a torque largely exceeding ratings.
A.72					Overload for Continuous Maximum Load	The motor was operating continuously under a torque largely exceeding ratings.
A.73					Dynamic Brake Overload	When the dynamic brake was applied, rotational energy exceeded the capacity of dynamic brake resistor.
A.74					Overload of Surge Current Limit Resistor	The main circuit power was frequently turned ON and OFF.
A.7A					Heat Sink Overheated* ¹	Heat sink of SERVOPACK is overheated.

Alarm Display	Alarm Code Outputs			ALM Output	Alarm Name	Description
	ALO1	ALO2	ALO3			
A.81	OFF	OFF	OFF	OFF	Absolute Encoder Backup Error* ²	All the power supplies for the absolute encoder have failed and position data was cleared.
A.82					Encoder Checksum Error* ²	The checksum results of encoder memory is abnormal.
A.83					Absolute Encoder Battery Error	Battery voltage for the absolute encoder has lowered.
A.84					Absolute Encoder Data Error* ²	Data in the encoder is abnormal.
A.85					Absolute Encoder Over-speed	The encoder was rotating at high speed when the power was turned ON.
A.86					Encoder Overheated	The internal temperature of encoder is too high.
A.b1					Reference Speed Input Read Error	The A/D converter for reference speed input is defective.
A.b2					Reference Torque Input Read Error	The A/D converter for reference torque input is defective.
A.b6					Gate Array Error	Communications LSI error
A.bF					System Alarm* ²	A system error occurred in the SERVOPACK.
A.C1	ON	OFF	ON		OFF	Servo Overrun Detected
A.C8				Absolute Encoder Clear Error and Multi-turn Limit Setting Error* ²		The multi-turn for the absolute encoder was not properly cleared or set.
A.C9				Encoder Communications Error* ²		Communications between SERVOPACK and encoder is not possible.
A.CA				Encoder Parameter Error* ²		Encoder parameters are incorrect.
A.Cb				Encoder Echoback Error* ²		Contents of communications with encoder is incorrect.
A.CC				Multi-turn Limit Mismatch		Different multi-turn limits have been set in the encoder and SERVOPACK.
A.d0	ON	ON	OFF	OFF	Position Error Pulse Overflow	Position error pulse exceeded parameter (Pn505).

Alarm Display	Alarm Code Outputs			ALM Output	Alarm Name	Description
	ALO1	ALO2	ALO3			
A.E0	OFF	ON	ON	OFF	No NS310 Unit *2	No NS310 Unit installed.
A.E1					NS310 Unit Timeout *2	No response from the board in the NS310 Unit.
A.E2					Watchdog Counter Error of NS310 Unit *2	WDC error in the board in the NS310 Unit
A.E6					DeviceNet Duplicate MAC ID Error *2	Same node address already exists on the DeviceNet network.
A.E7					No NS310 Unit Detected	No NS310 Unit detected.
A.E8					Switch Setting Error *2	Unit rotary switch setting error
A.E9					DeviceNet BUS-OFF Error	Fatal communications error has occurred in DeviceNet communications.
A.EA	OFF	ON	ON		OFF	SGDH System Error *2
A.EB	OFF	ON	ON	OFF	SERVOPACK Initial Access Error *2	Initial processing failed.
A.EC					Watchdog Counter Error of NS310 Unit	SERVOPACK WDC error.
A.ED					Option System Error	Command was interrupted.
A.F1	OFF	ON	OFF	OFF	Power Line Open Phase	One phase is not connected in the main power supply.
CPF00	Not specified				Hand-held Digital Operator Transmission Error	The Hand-held Digital Operator (JUSP-OP02A-2) fails to communicate with SERVOPACK (e.g., CPU error).
CPF01						
A.--	OFF	OFF	OFF	ON	Not an error	Normal operation status

Note OFF: Output transistor is OFF (high). ON: Output transistor is ON (low).

- * 1. This alarm display appears only within the range of 30 W to 1000 W.
- * 2. These alarms are not reset for the alarm clear (ALM-CLR) command. Eliminate the cause of the alarm and then turn OFF the power supply to reset the alarms.
- * 3. For SERVOPACKs with a capacity of 6.0 kw or more, A.40 indicates a main circuit voltage error alarm. This means that either an overvoltage or an undervoltage has occurred at some stage.

9.4 Warning Displays

The relation between warning displays and warning code outputs are shown in the following table.

Warning code are not normally output, but when warning code output is specified in the parameter, they are as shown in the following table.

Table 9.3 Warning Displays and Outputs

Warning Display	Warning Code Outputs			ALM Output	Warning Name	Description of Warning
	ALO1	ALO2	ALO3			
A.91	OFF	ON	ON	ON	Overload	This warning occurs before the overload alarms (A.71 or A.72) occur. If the warning is ignored and operation continues, an overload alarm may occur.
A.92	ON	OFF	ON	ON	Regenerative Overload	This warning occurs before the regenerative overload alarm (A.32) occurs. If the warning is ignored and operation continues, a regenerative overload alarm may occur.
A.94	ON	ON	OFF	ON	Parameter Setting Warning	A value outside the setting range was set using DeviceNet communications.
A.95	OFF	ON	OFF	ON	Command Warning	A command not supported in the product specifications was issued. The command reception conditions were not met.
A.96	ON	OFF	OFF	ON	Communications Warning	A communications error occurred. (Once)
A.97	OFF	OFF	OFF	ON	Control Power OFF	The control power supply is not being supplied.
A.98	ON	ON	ON	ON	Main Power OFF	The main power supply is not being supplied.

Note OFF: Output transistor is OFF (high). ON: Output transistor is ON (low).

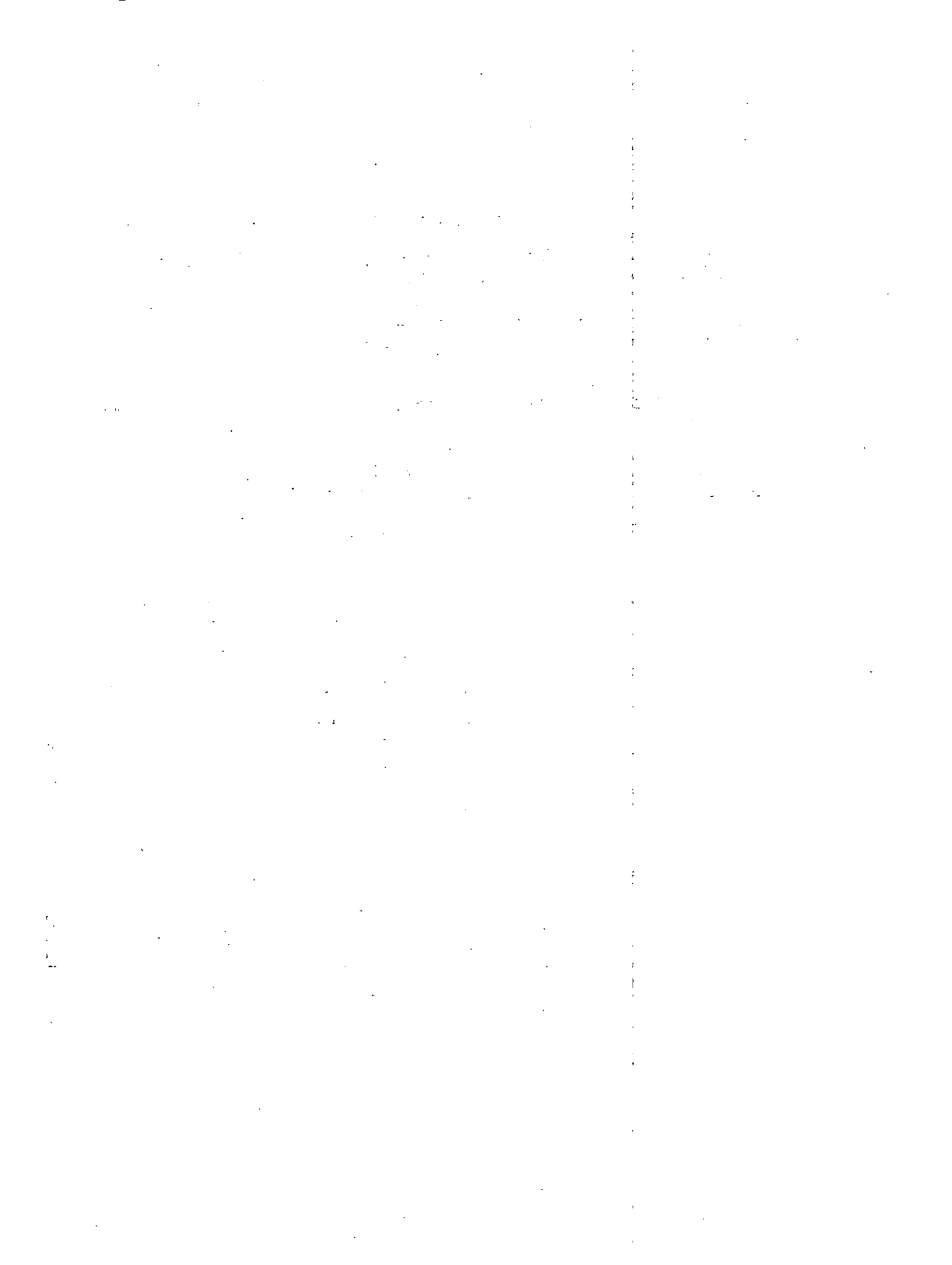

A

A

DeviceNet Object Model

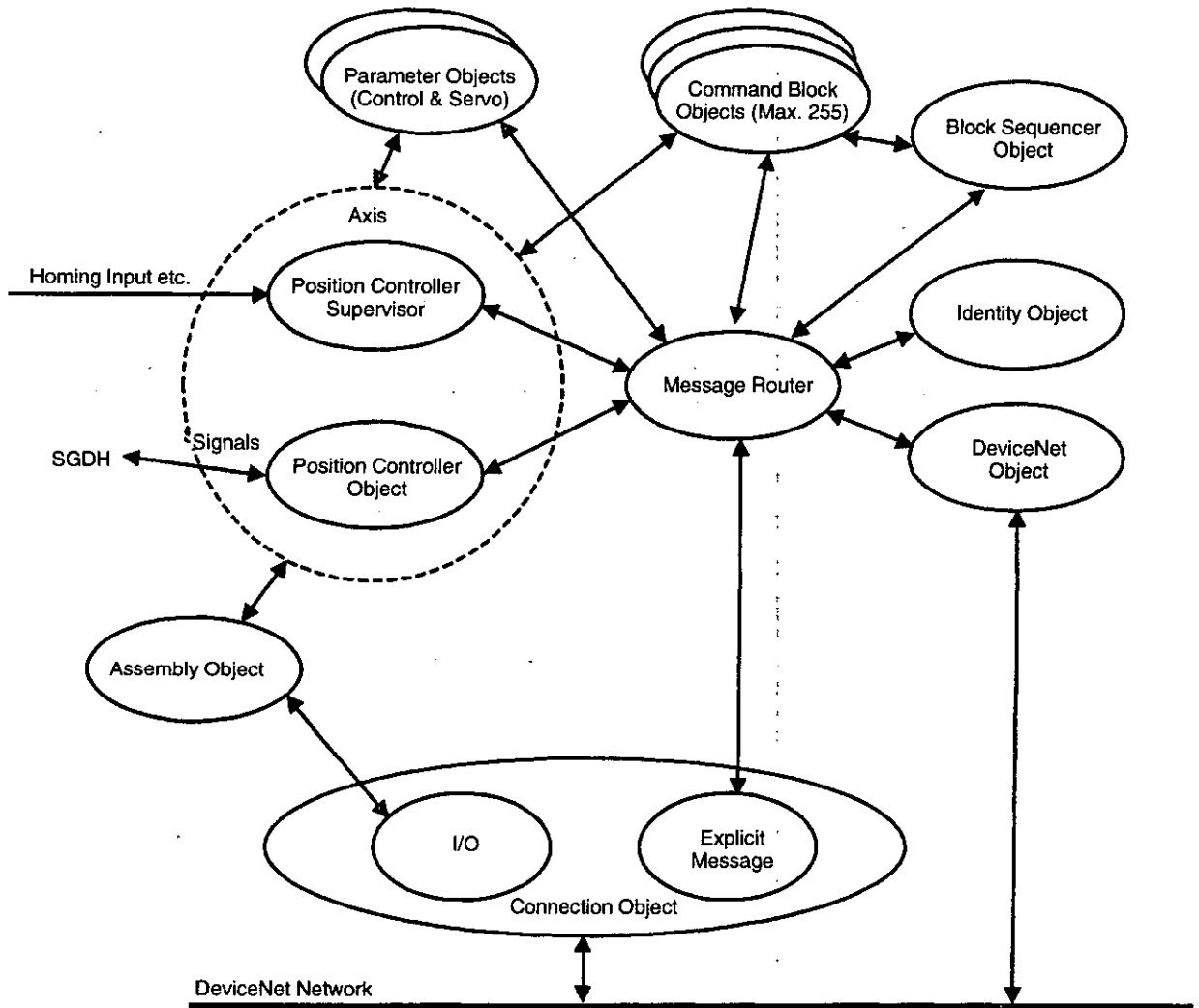
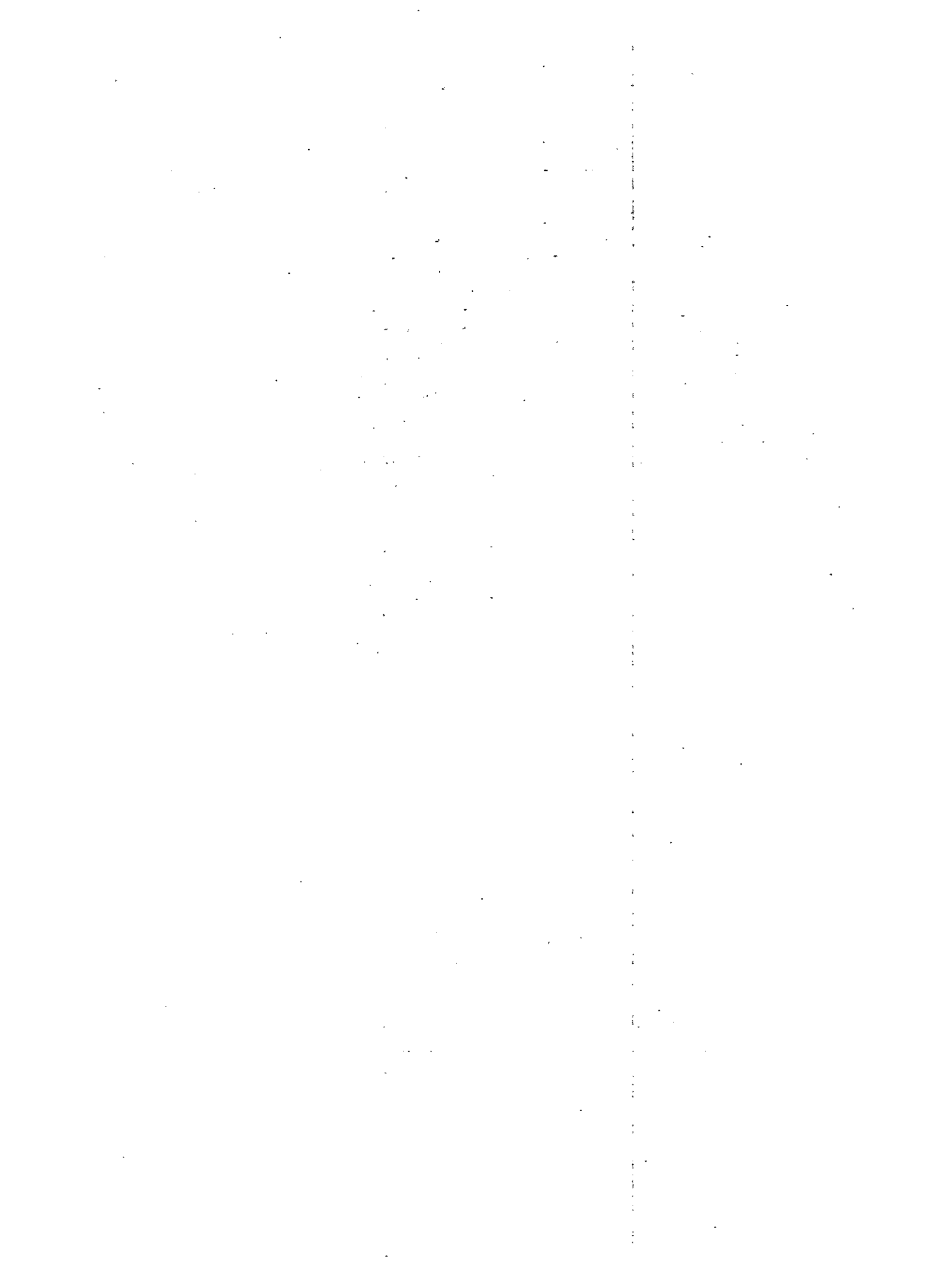

Figure A.1 DeviceNet Object Model

Object Class	Class Code	Instance No.	Function
Identity	0x01	1	Manages ID information, such as the device type, serial number, vendor, and ID.
Message Router	0x02	1	Routes explicit messages to the appropriate object.
DeviceNet	0x03	1	Manages the physical connection to the DeviceNet, and performs Master/Slave connection set and release demands.
Assembly	0x04	1	Manages I/O output messages for Slave to Master.
		2	Manages I/O input messages from Master to Slave.
Connection	0x05	1	Manages explicit messages attributes.
		2	Manages I/O message (polled I/O) attributes.
Position Controller Supervisor	0x24	1	Manages homing, external positioning, command codes, response codes, alarm attributes, etc.
Position Controller	0x25	1	Manages motion profile, servomotor interface, limit attributes, etc.
Block Sequencer	0x26	1	Executes block commands and block sequences.
Command Block	0x27	255	Manages block commands.
Control Parameter	0x64	1	Manages position controller engine parameters.
Servo Parameter	0x66	1	Manages parameters within SGDH SERVOPACK.





B

DeviceNet Attributes

B

This appendix lists the objects and attributes that can be used in DeviceNet.

B.1 Identity Object (0x01)	B - 2
B.2 Message Router Object (0x02)	B - 3
B.3 DeviceNet Object (0x03)	B - 4
B.4 Assembly Object (0x04)	B - 5
B.5 Connection Object (0x05)	B - 6
B.6 Position Controller Supervisor Object (0x24)	B - 8
B.7 Position Controller Object (0x25)	B - 9
B.8 Block Sequencer Object (0x26)	B - 12
B.9 Command Block Object (0x27)	B - 13
B.10 Control Parameter Object (0x64)	B - 14
B.11 SERVOPACK Parameter Object (0x66) .	B - 18

B.1 Identity Object (0x01)

1. Class

Attributes: None supported

Services: None supported

2. Instances

Attributes

No	Access	Name	Data Type	Description	Value
1	Get	Vendor ID	UINT	Identification of each vendor by number	0x44
2	Get	Device Type	UINT	Identification of general type of product	0x00
3	Get	Product Code	USINT	Identification of a particular product of an individual vendor	0x51
4	Get	Revision	---	Revision of the item the Identity Object represents	1.0
5	Get	Status	WORD	Summary status of device	---
6	Get	Serial Number	UDINT	Serial number of device	Each unit
7	Get	Product Name	STRING	Human readable identification	JUSP-NS310

Services

Service Code	Service	Description
0x05	Reset	Invokes the Reset Service for the device.
0x0E	Get_Attribute_Single	Returns the contents of the specified attribute.

B.2 Message Router Object (0x02)

1. Class

Attributes: None supported

Services: None supported

2. Instances

Attributes: None supported

Services: None supported



B.3 DeviceNet Object (0x03)

1. Class

Attributes: None supported

Services: None supported

2. Instances

Attributes

No.	Access	Name	Data Type	Description	Value
1	Get	MAC ID	USINT	Node address	Range 0 to 63
2	Get	Baud Rate	USINT	Baud Rate	Range 0 to 2
3	Get	BOI	BOOL	BUS-OFF interrupt	0x00
4	Get	Bus-Off Counter	USINT	Number of times CAN went to the BUS-OFF state	Range 0 to 255
5	Get	Allocation Information	STRUCT of:	---	---
---	---	Allocation Choice Byte	Byte	Active connection of Predefined Master/Slave Connection Set	---
---	---	Master's MAC ID	USINT	MAC ID of Master	Range 0 to 63

Services

Service Code	Name	Description
0x0E	Get_Attribute_Single	Returns the contents of the specified attribute.
0x4B	Allocate_Master/Slave_Connection_Set	Requests the use of the Predefined Master/Slave Connection Set.
0x4C	Release_Master/Slave_Connection_Set	Indicates that the specified connections within the Predefined Master/Slave Connection Set are no longer desired.

B.4 Assembly Object (0x04)

1. Class

Attributes: None supported

Services: None supported

2. Instances

Attributes: None supported

Services: None supported

B

B.5 Connection Object (0x05)

1. Class

Attributes: None supported

Services: None supported

2. Instances

Attributes (Instance 1: Explicit Message)

No.	Access	Name	Data Type	Description	Value
1	Get	State	USINT	Defines the state of the object.	---
2	Get	Instance_type	USINT	Defines either I/O or messaging connection.	0x0000
3	Get	Transport Class_trigger	Byte	Defines behavior of the connection.	0x8300
4	Get/Set	Produced_Connection_ID	UINT	Placed in CAN Identifier Field when the Connection transmits	---
5	Get/Set	Consumed_Connection_ID	UINT	CAN Identifier Field value that denotes message to be received	---
6	Get/Set	Initial_Comm_Characteristics	USINT	Defines the message group across which productions and consumption associated with this connection occur.	0x2100
7	Get	Produced_Connection_Size	UINT	Maximum number of bytes transmitted across this connection	0xff00
8	Get	Consumed_Connection_Size	UINT	Maximum number of bytes received across this connection	0xff00
9	Get/Set	Expected_Packet_Rate	UINT	Defines timing associated with this connection.	---
12	Get	Watchdog_Timeout_Action	USINT	Defines how to handle inactivity/watchdog timeouts.	0x0100
13	Get	Produced_Connection_Path_Length	UINT	Number of bytes in the produced connection path attribute	0x0000
14	Get	Produced_Connection_Path	USINT Array	Specified the application object whose data is to be produced by this connection object	---
15	Get	Consumed_Connection_Path_Length	UINT	Number of bytes in the consumed connection path attribute	0x0000
16	Get	Consumed_Connection_Path	USINT Array	Specified the application object that are to receive the data received by this connection object	---

Attributes (Instance 2: Polled I/O)

No.	Access	Name	Data Type	Description	Value
1	Get	State	USINT	State of the object	---
2	Get	Instance_type	USINT	Indicates either I/O or messaging connection.	0x0001
3	Get	Transport Class_trigger	Byte	Defines behavior of the connection.	0x8200
4	Get/Set	Produced_Connection_ID	UINT	Placed in CAN Identifier Field when the connection transmits	---
5	Get/Set	Consumed_Connection_ID	UINT	CAN Identifier Field value that denotes message to be received	---
6	Get/Set	Initial_Comm_Characteristics	USINT	Defines the message group across which productions and consumption associated with this connection occur.	0x0100
7	Get	Produced_Connection_Size	UINT	Maximum number of bytes transmitted across this connection	0x0800
8	Get	Consumed_Connection_Size	UINT	Maximum number of bytes received across this connection	0x0800
9	Get/Set	Expected_Packet_Rate	UINT	Defines timing associated with this connection.	---
12	Get	Watchdog_Timeout_Action	USINT	Defines how to handle inactivity/watchdog timeouts.	0x0100
13	Get	Produced_Connection_Path_Length	UINT	Number of bytes in the produced connection path attribute.	0x0000
14	Get	Produced_Connection_Path	USINT Array	Specified the application object whose data is to be produced by this connection object	00_00_ 00_00_ 00_00_
15	Get	Consumed_Connection_Path_Length	UINT	Number of bytes in the consumed connection path attribute	0x0000
16	Get	Consumed_Connection_Path	USINT Array	Specified the application object that are to receive the data consumed by this connection object	00_00_ 00_00_ 00_00_

Services

Service Code	Name	Description
0x0E	Get_Attribute_Single	Returns the contents of the specified attribute.
0x10	Set_Attribute_Single	Modifies the contents of the specified attribute.
0x05	Reset	Resets the designated instance.

B.6 Position Controller Supervisor Object (0x24)

1. Class

Attributes: None supported

Services: None supported

2. Instances

Attributes

No.	Access	Name	Data Type	Description	Value
1	Get	Number of Attributes	USINT	The total number of attributes supported by this device.	Range 0 to 255
2	Get	Attribute List	Array of USINT	Return an array with a list of the attributes supported by this device.	Array size defined by attribute 1
3	Get	Axis Instance	USINT	Axis number	Constant (1)
5	Get	General Fault	BOOL	General fault flag. This bit is reset when the fault is removed.	1 = fault
6	Set	Command Assembly Type	USINT	Sets the command assembly type.	1 = Assy 01 2 = Assy 02 etc.
7	Set	Response Assembly Type	USINT	Sets the response assembly type.	1 = Assy 01 2 = Assy 02 etc.
11	Set	Home Active Level	BOOL	Home trigger Active Level Flag is used to program the home position input active level.	0 = active low 1 = active high
12	Get/Set	Home Arm	BOOL	Home trigger arm flag is used to set the home position input to 1.	Setting to 1 indicates the home input, and reading a 0 indicates the trigger has occurred.
16	Get	Home Input Level	BOOL	Actual level of the home position input	0 = low 1 = high
17	Get	Home Position	DINT	Home trigger position reflects the position at the time the home position input is triggered.	Range 0x80000001 to 0x7fffffff

Services

Service Code	Name	Description
0x0E	Get_Attribute_Single	Returns the specified attribute.
0x10	Set_Attribute_Single	Sets the specified attribute.

B.7 Position Controller Object (0x25)

1. Class

Attributes: None supported

Services: None supported

2. Instances

Attributes

No.	Access	Name	Data Type	Description	Value
1	Get	Number of Attributes	USINT	Returns the number of attributes supported by this device.	Range: 0 to 255
2	Get	Attribute List	Array of USINT	Returns an array with a list of the attributes supported by this device	Array Size Defined by Attribute 1
3	Get/Set	Mode	USINT	Operating mode	0: Position 1: Speed
6	Get/Set	Target Position	DINT	Sets target position. Unit: step	Range -99,999,999 to +99,999,999
7	Get/Set	Target Speed	DINT	Sets the target speed. Unit: step/s	Set to a positive number
8	Get/Set	Acceleration	DINT	Acceleration for positioning Unit: step/s ²	Set to a positive number
9	Get/Set	Deceleration	DINT	Deceleration for positioning Unit: step/s ²	Set to a positive number
10	Get/Set	Incremental Position	BOOL	Sets the absolute/incremental positioning.	0: Absolute 1: Incremental
11	Get/Set	Trajectory Start/Complete	BOOL	Set to start a trajectory move. Reads that the NS310 Unit is cleared when a profile move is completed.	1: Trajectory start, in motion 0: Move complete
12	Get	On-target Position	BOOL	This flag means which actual position is On-Target position.	1: On-Target position
13	Get/Set	Actual Position	DINT	Return the actual position. Unit: step	Range -99,999,999 to +99,999,999
14	Get	Actual Speed	DINT	Return the actual speed. Unit: step/s	Positive number
15	Get	Commanded Position	DINT	Return the commanded position. Unit: step	Range -99,999,999 to +99,999,999
16	Get	Commanded Speed	DINT	Return the commanded speed. Unit: step/s	Positive number

No.	Access	Name	Data Type	Description	Value
17	Get/Set	Enable	BOOL	Sets the Servo ON/OFF.	0: Servo OFF 1: Servo ON
18	Get/Set	Profile Type	USINT	Profile Type defines the type of move profile.	0, 1, 2, or 240 to 245
19	Get/Set	Profile Gain	DINT	This attribute provides a gain value for non-trapezoidal profiles, such as S-curve profiling.	4 to 1000
20	Get/Set	Smooth Stop	BOOL	Sets the Smooth Stop command.	---
21	Get/Set	Hard Stop	BOOL	Sets the Hard Stop command.	---
22	Set	Jog Speed	DINT	Sets the speed for continuous speed mode. Unit: step/s	Set to a positive number.
23	Get/Set	Direction	BOOL	Sets the direction for continuous speed mode.	0: Negative 1: Positive
24	Get/Set	Reference Direction	BOOL	Defines positive direction (when viewed from the motor shaft side).	0: CW is positive. 1: CCW is positive.
26	Get/Set	Positive Torque Limit	DINT	This value sets the maximum allowable torque output in the positive direction. Unit: %	Range: 0 to 800
27	Get/Set	Negative Torque Limit	DINT	This value sets the maximum allowable torque output in the negative direction. Unit: %	Range: -800 to 0
30	Get/Set	Kp	INT	Proportional gain of position loop. Unit: 1/s	Range: 1 to 2000
38	Set	Position Deadband	USINT	Sets the value of position deadband. Unit: step	Range: 0 to 255
45	Get/Set	Max Dynamic Following Error	DINT	Maximum allowable following error. If difference between actual and commanded position exceeds this value, the Following Error Flag is set. Unit: 256 pulse	Range: 256 to 8388352
47	Get/Set	Following Error Fault	BOOL	Following Error Flag set when a following error occurs.	1: Following error occurred
49	Get/Set	Hardware Limit Action	USINT	Defines the response to a hardware limit.	0: Servo OFF 1: Hard Stop 2: Smooth Stop
50	Get	Positive Hardware Limit	BOOL	Set when move exceeds positive hardware limit.	0: Inactive 1: Active
51	Get	Negative Hardware Limit	BOOL	Set when move exceeds negative hardware limit.	0: Inactive 1: Active

No.	Access	Name	Data Type	Description	Value
52	Get/Set	Software Limit Enable	BOOL	Enables the software limit action.	0: Disable 1: Enable
54	Get/Set	Positive Software Limit Position	DINT	Sets the software positive position limit. Unit: step	Range -99,999,999 to +99,999,999
55	Get/Set	Negative Software Limit Position	DINT	Sets the software negative position limit. Unit: step	Range -99,999,999 to +99,999,999
56	Get	Positive Limit State	BOOL	Monitors the software positive position limit.	1: Exceeded positive limit
57	Get	Negative Limit State	BOOL	Monitors the software negative position limit.	1: Exceeded negative limit
231	Get/Set	Hardware Limit Enable	BOOL	Enables the hardware limit action in response to a hardware limit input.	0: Disable 1: Enable
232	Get/Set	Hardware Limit Input Logic	BOOL	Defines the logic of the hardware limit input.	0: Normally Closed 1: Normally Open
241	Get/Set	Emergency Stop Action	USINT	Defines the emergency stop behavior.	0: Hard stop and servo OFF
242	Get/Set	Emergency Stop Enable	BOOL	Enables the emergency stop input.	0: Disable 1: Enable
243	Get/Set	Emergency Stop Logic	BOOL	Defines the logic of the emergency stop input.	0: Low Active 1: High Active
244	Get	Emergency Stop State	BOOL	Monitors the state of the emergency stop.	0: Inactive 1: Active
253	Get/Set	Home Direction	BOOL	Defines the initial direction of the move for homing.	0: Negative direction 1: Positive direction
254	Get/Set	Home Fast Speed	DINT	The fast speed used during homing Unit: step/s	Positive number
255	Get/Set	Home Slow Speed	DINT	The slow speed used during homing Unit: step/s	Positive number

Services

Service Code	Name	Description
0x0E	Get_Attribute_Single	Returns the specified attribute.
0x10	Set_Attribute_Single	Sets the specified attribute.

B.8 Block Sequencer Object (0x26)

1. Class

Attributes: None supported

Services: None supported

2. Instances

Attributes

No.	Access	Name	Data Type	Description	Value
1	Get/Set	Block	USINT	Instance number of starting command block	Range: 1 to 255
2	Get/Set	Block Execute	BOOL	Starts the execution of the block defined in block (1).	1: Starts executing block or chain of block. 0: Block or chain of blocks is done.
3	Get	Current Block	USINT	Reports the current executing block.	Range: 1 to 255
4	Get	Block Fault	BOOL	Sets when a block error occurs. When a block fault occurs, block execution will stop. This bit is reset when the Block Fault Code (5) is read.	1: Block fault
5	Get	Block Fault Code	USINT	Defines the specific block fault.	0: No fault 1: Invalid or empty block data 2: Comm and timeout 3: Execution fault

Services

Service Code	Name	Description
0x0E	Get_Attribute_Single	Returns the specified attribute.
0x10	Set_Attribute_Single	Sets the specified attribute.

B.9 Command Block Object (0x27)

1. Class

Attributes: None supported

Services: None supported

2. Instances

Attributes

No.	Access	Name	Data Type	Description	Value
1	Get/Set	Block Command	USINT	Defines the format of the command data.	1: Modify attribute 2: Wait Equal etc.
2	Get/Set	Block Link Number	USINT	This value provides a link to the next block instance to execute. When this block is done, the link block will be executed.	Link block Instance number 0x00 is end of link.
3	Get/Set	Depends on Command Number	---	Defines a command attribute.	---
4	Get/Set	Depends on Command Number	---	Defines a command attribute.	---
5	Get/Set	Depends on Command Number	---	Defines a command attribute.	---
6	Get/Set	Depends on Command Number	---	Defines a command attribute.	---
7	Get/Set	Depends on Command Number	---	Defines a command attribute.	---

Services

Service Code	Name	Description
0x01	Get_Attribute_All	Returns a predefined listing of this Objects attributes.
0x02	Set_Attribute_All	Modifies the contents of the attributes of this object.
0x0E	Get_Attribute_Single	Returns the specified attribute.
0x10	Set_Attribute_Single	Sets the specified attribute.

B

B.10 Control Parameter Object (0x64)

1. Class

Attributes: None supported

Services: None supported

2. Instances

Attributes:

No.	Access	Name	Data Type	Description	Value
11	Get/Set	Homing Function Selection	UINT	Sets the function selection for homing.	0, 1
12	Get/Set	Feed Speed For Homing	DINT	Sets the feed speed for homing. Unit: 1000 step/min	Range: 1 to 240,000
13	Get/Set	Home Fast Speed for Homing	DINT	Sets the home fast speed for homing. Unit: 1000 step/min	Range: 1 to 240,000
14	Get/Set	Home Slow Speed For Homing	DINT	Sets the home slow speed for homing. Unit: 1000 step/min	Range: 1 to 240,000
15	Get/Set	Final travel Distance for Homing	DINT	Sets the final travel distance for homing. Unit: step	Range: 0 to 99,999,999
17	Get	Home Position Offset	DINT	Returns the home position offset. Unit: step	Range: -99,999,999 to +99,999,999
30	Get/Set	Electric Gear (Numerator)	DINT	Sets the numerator of electric gear.	Positive number
31	Get/Set	Electric Gear (Denominator)	DINT	Sets the denominator of electric gear.	Positive number
32	Get/Set	Coordinate Type	BOOL	Sets the coordinate type.	0: Linear 1: Rotary
33	Get/Set	Command value per machine rotation	DINT	Sets the command value per one machine rotation for rotary axis. Unit: step	Range: 1 to 1,500,000
34	Get/Set	Backlash compensation	DINT	Sets the compensated value for backlash. Unit: step	Range: 0 to 32,767
35	Get/Set	Backlash compensation direction	BOOL	Sets the direction for backlash compensation.	0: Positive 1: Negative
36	Get/Set	Positive Software Limit	DINT	Sets the limit position for positive direction. Unit: step	Range: -99,999,999 to +99,999,999

No.	Access	Name	Data Type	Description	Value
37	Get/Set	Negative Software Limit	DINT	Sets the limit position for negative direction. Unit: step	Range: -99,999,999 to +99,999,999
38	Get/Set	Function Selection 1	UINT	b0: Software Limit Enable 0: Disable 1: Enable b1: Backlash Compensation 0: Disable 1: Enable	---
39	Get/Set	Hardware Limit Function Selection	USINT	B0: Hardware Limit Enable 0: Disable 1: Enable B1: Hardware Limit Input Logic 0: Active Low 1: Active High	---
40	Get/Set	Hardware Limit Action	USINT	Sets the action when exceeding to hardware limit.	0: Servo OFF 1: Hard Stop 2: Smooth Stop
41	Get/Set	Emergency Input Function Selection	USINT	B0: Emergency Stop Enable 0: Disable 1: Enable B1: Emergency Stop Input Logic 0: Active Low 1: Active High	---
42	Get/Set	Emergency Stop Action	USINT	Sets the action when emergency stop.	0: Hard Stop and Servo OFF
51	Get/Set	Feed Speed for Positioning	DINT	Sets the feed speed for positioning. Unit: 1000 step/min	Range: 1 to 240,000
52	Get/Set	Acceleration/Deceleration Time constant	UINT	Sets the time constant of acceleration/deceleration for positioning. Unit: ms	Range: 1 to 10,000
53	Get/Set	Deceleration Time Constant for Asymmetric	DINT	Sets the time constant of deceleration for asymmetric acceleration/deceleration. Unit: ms	Range: 1 to 10,000
54	Get/Set	Switch Speed of second Accel/Decel	DINT	Sets the switch speed for second acceleration/deceleration time constant. Unit: 1000 step/min	Range: 1 to 240,000
55	Get/Set	Accel/Decel time Constant of Second A/D	UINT	Sets the time constant of second acceleration/deceleration for positioning. Unit: ms	Range: 1 to 10,000
56	Get/Set	Accel/Decel Type for Positioning	USINT	Sets acceleration/deceleration type for positioning. 0: None 1: Single step linear 2: Double step linear 3: Asymmetric linear	---

No.	Access	Name	Data Type	Description	Value
58	Get/Set	Filter Selection	USINT	Sets the type of filter. 0: None 1: Exponent 2: Exponent with bias 3: Moving average	---
60	Get/Set	Feed Speed For Jog	DINT	Sets the feed speed for speed mode. Unit: 1000 step/min	Range: 1 to 240,000
61	Get/Set	Acceleration/Deceleration Time Constant For JOG	UINT	Sets the time constant of acceleration/deceleration for speed mode. Unit: ms	Range: 1 to 10,000
62	Get/Set	Deceleration Time Constant For JOG	UINT	Sets the time constant of deceleration of asymmetric for speed mode. Unit: ms	Range: 1 to 10,000
63	Get/Set	Switch Speed of Second Accel/Decel for JOG	DINT	Sets the switch speed for second acceleration/deceleration time constant. Unit: 1000 step/min	Range: 1 to 240,000
64	Get/Set	Second A/D Time constant For JOG	UINT	Sets the time constant of second acceleration/deceleration for JOG. Unit: ms	Range: 1 to 10,000
65	Get/Set	Profile Type For JOG	USINT	Sets acceleration/deceleration type for speed mode. 0: None 1: Single step linear 2: Double step linear 3: Asymmetric linear	---
70	Get/Set	Time Constant For Exponential Curve	UINT	Sets the time constant of exponential acceleration/deceleration. Unit: ms	---
71	Get/Set	Bias Speed	DINT	Sets the bias speed of exponential acceleration/deceleration. Unit: 1000 step/min	Range: 1 to 240,000
72	Get/Set	Time constant of Moving Average	UINT	Sets the time constant of moving average. Unit: ms	Range: 4 to 4,000
73	Get/Set	Maximum Feed Speed	DINT	Sets the maximum feed speed. Unit: 1000 step/min	Range: 1 to 240,000
90	Get/Set	Positioning Deadband	UINT	Sets the deadband of positioning. Unit: step	Range: 1 to 10,000
91	Get/Set	Positioning Timeout	UINT	Sets the timeout value when positioning is completed. Unit: ms	Range: 0 to 100,000

Services

Service Code	Name	Description
0x0E	Get_Attribute_Single	Returns the specified attribute.
0x10	Set_Attribute_Single	Sets the specified attribute.



B.11 SERVOPACK Parameter Object (0x66)

1. Class

Attributes: None supported

Services: None supported

2. Instances

Attributes

No.	Access	Name	Data Type	Description	Value
10	Get/Set	Basic Function Selection	UINT	Sets function selection basic switch.	Default: 0000
11	Get/Set	Application Switch 1	UINT	Sets function selection application switches 1.	Default: 0000
12	Get/Set	Application Switch 2	UINT	Sets function selection application switches 2.	Default: 0000
13	Get/Set	Application Switch 3	UINT	Sets function selection application switches 3.	Default: 0002
14	Get/Set	Application Switch 4	UINT	Sets function selection application switches 4.	Default: 0000
15	Get/Set	Application Switch 5	UINT	Sets function selection application switches 5.	Default: 0000
50	Get/Set	Speed Loop Gain	UINT	Sets the speed loop gain. Unit: Hz	Range: 1 to 2000 Default: 40
51	Get/Set	Integral time Constant for Speed loop	UINT	Sets the integral time constant for speed loop. Unit: 0.01ms	Range: 15 to 51200 Default: 2000
52	Get/Set	Position Loop Gain	UINT	Sets the position loop gain. Unit: 1/s	Range: 1 to 2000 Default: 40
53	Get/Set	Inertia Ratio	UINT	Sets the inertia ratio. Unit: %	Range: 0 to 10000 Default: 0
54	Get/Set	Second Speed Loop Gain	UINT	Sets the second speed loop gain. Unit: Hz	Range: 1 to 2000 Default: 40
55	Get/Set	Integral time Constant for Second Speed loop	UINT	Sets the integral time constant for second speed loop. Unit: 0.01ms	Range: 15 to 51200 Default: 2000
56	Get/Set	Second Position Loop Gain	UINT	Sets the second position loop gain. Unit: 1/s	Range: 1 to 2000 Default: 40
57	Get/Set	Bias	UINT	Sets the bias. Unit: r/min	Range: 0 to 450 Default: 0
58	Get/Set	Bias width Addition	UINT	Sets the bias width addition. Unit: 0.001 mm	Range: 0 to 250 Default: 7

No.	Access	Name	Data Type	Description	Value
59	Get/Set	Feedforward	UINT	Sets the feed forward gain. Unit: %	Range: 0 to 100 Default: 0
60	Get/Set	Feedforward Filter Time Constant	UINT	Sets the feed forward filter time constant. Unit: 0.01 ms	Range: 0 to 6400 Default: 0
61	Get/Set	Gain-related Application Switch	UINT	Sets the gain-related application switches.	---
62	Get/Set	Mode Switch Torque Reference	UINT	Sets the mode switch torque reference. Unit: %	Range: 0 to 800 Default: 200
63	Get/Set	Mode Switch Speed Reference	UINT	Sets the mode switch speed reference. Unit: min^{-1}	Range: 0 to 10000 Default: 0
64	Get/Set	Mode Switch Acceleration	UINT	Sets the mode switch acceleration. Unit: 10 min^{-1}	Range: 0 to 3000 Default: 0
65	Get/Set	Mode Switch Error Pulse	UINT	Sets the mode switch error pulse. Unit: 0.001 mm	Range: 0 to 10000 Default: 0
66	Get/Set	Online Autotuning	UINT	Sets the online autotuning switches.	Default: 10
67	Get/Set	Speed Feedback Compensation	UINT	Sets the speed feedback compensation. Unit: %	Range: 0 to 500 Default: 100
68	Get/Set	Fixed Parameters	UINT	Unit: %	Range: 0 to 1000 Default: 100
69	Get/Set	Fixed Parameters	UINT	---	Range: 0 to 1000 Default: 1000
70	Get/Set	Fixed Parameters	UINT	---	Range: 0 to 1000 Default: 200
71	Get/Set	Fixed Parameters	UINT	---	Range: 0 to 65535 Default: 32
72	Get/Set	Fixed Parameters	UINT	---	Range: 0 to 65535 Default: 16
73	Get/Set	Fixed Parameters	UINT	Unit: %	Range: 20 to 100 Default: 100
74	Get/Set	Fixed Parameters	UINT	Unit: %	Range: 20 to 100 Default: 100
75	Get/Set	Fixed Parameters	UINT	Unit: 1/s	Range: 1 to 2000 Default: 50
76	Get/Set	Fixed Parameters	UINT	Unit: 0.1%	Range: 1 to 2000 Default: 1000
77	Get/Set	Fixed Parameters	UINT	Unit: Hz	Range: 1 to 150 Default: 50

DeviceNet Attributes

No.	Access	Name	Data Type	Description	Value
78	Get/Set	Fixed Parameters	UINT	Unit: Hz	Range: 1 to 150 Default: 70
79	Get/Set	Fixed Parameters	UINT	Unit: %	Range: 0 to 150 Default: 100
80	Get/Set	Fixed Parameters	UINT	Unit: %	Range: 0 to 150 Default: 100
81	Get/Set	Fixed Parameters	UINT	Unit: ms	Range: 0 to 2000 Default: 0
82	Get/Set	Fixed Parameters	UINT	Unit: 0.01 ms	Range: 0 to 51200 Default: 0
83	Get/Set	Fixed Parameters	UINT	Unit: Hz	Range: 10 to 250 Default: 50
84	Get/Set	Fixed Parameters	UINT	Unit: Hz	Range: 0 to 250 Default: 0
85	Get/Set	Fixed Parameters	UINT	Unit: %	Range: 0 to 100 Default: 0
100	Get/Set	Position Control Reference Switches	UINT	Sets the position control reference selection switches.	Default: 0000
101	Get/Set	PG Divider	UINT	Sets the PG divider. Unit: p/r	Range: 16 to 16384 Default: 16384
102	Get/Set	Numerator Gear Ratio	UINT	Sets the electric gear ratio numerator.	Range: 1 to 65535 Default: 4
103	Get/Set	Denominator Gear Ratio	UINT	Sets the electric gear ratio denominator.	Range: 1 to 65535 Default: 1
104	Get/Set	Position A/D Constant	UINT	Sets the position reference acceleration/deceleration constant. Unit: 0.01 ms	Range: 0 to 6400 Default: 0
105	Get/Set	Multi-turn Limit	UINT	Sets the multi-turn limit setting. Unit: rev	Range: 0 to 65535 Default: 65535
106	Get/Set	Fixed Parameter	UINT	Unit: P/rev	Range: 513 to 65535 Default: 16384
107	Get/Set	Position Control Switches	UINT	Sets the position control function switches.	Default: 0000
108	Get/Set	Position move Average time	UINT	Sets the position reference movement averaging time. Unit: 0.01 ms	Range: 0 to 6400 Default: 0

No.	Access	Name	Data Type	Description	Value
120	Get/Set	Speed Reference Input Gain	UIINT	Sets the speed reference input gain. Unit: 0.01 V/rated speed	Range: 150 to 3000 Default: 600
121	Get/Set	Speed 1	UIINT	Sets the speed 1. Unit: min ⁻¹	Range: 0 to 10000 Default: 100
122	Get/Set	Speed 2	UIINT	Sets the speed 2. Unit: min ⁻¹	Range: 0 to 10000 Default: 200
123	Get/Set	Speed 3	UIINT	Sets the speed 3. Unit: min ⁻¹	Range: 0 to 10000 Default: 300
124	Get/Set	JOG Speed	UIINT	Sets the JOG speed. Unit: min ⁻¹	Range: 0 to 10000 Default: 500
125	Get/Set	Soft Start Accel Time	UIINT	Sets the soft start acceleration time. Unit: ms	Range: 0 to 10000 Default: 0
126	Get/Set	Soft Start Decel Time	UIINT	Sets the soft start deceleration time. Unit: ms	Range: 0 to 10000 Default: 0
127	Get/Set	Speed Reference Time Constant	UIINT	Sets the speed reference filter time constant. Unit: 0.01 ms	Range: 0 to 65535 Default: 40
128	Get/Set	Speed Feed Forward Time Constant	UIINT	Sets the speed feed forward filter time constant. Unit: 0.01 ms	Range: 0 to 65535 Default: 0
140	Get/Set	Torque Reference Input Gain	UIINT	Sets the torque reference input gain. Unit: 0.01 V/rated speed	Range: 150 to 3000 Default: 600
141	Get/Set	Torque Reference Time Constant	UIINT	Sets the torque reference filter time constant. Unit: 0.01 ms	Range: 0 to 65535 Default: 100
142	Get/Set	Forward Torque Limit	UIINT	Sets the forward torque limit. Unit: %	Range: 0 to 800 Default: 800
143	Get/Set	Reverse Torque Limit	UIINT	Sets the reverse torque limit. Unit: %	Range: 0 to 800 Default: 800
144	Get/Set	Forward External Torque Limit	UIINT	Sets the forward external torque limit. Unit: %	Range: 0 to 800 Default: 100
145	Get/Set	Reverse External Torque Limit	UIINT	Sets the reverse external torque limit. Unit: %	Range: 0 to 800 Default: 100
146	Get/Set	Emergency Stop Torque	UIINT	Sets the emergency stop torque. Unit: %	Range: 0 to 800 Default: 800
147	Get/Set	Speed Limit	UIINT	Sets the speed limit during torque control. Unit: min ⁻¹	Range: 0 to 10000 Default: 10000

B

No.	Access	Name	Data Type	Description	Value
148	Get/Set	Torque Function Switches	UIINT	Sets the torque function switches.	Default: 0000
149	Get/Set	Notch Filter Frequency	UIINT	Sets the notch filter frequency. Unit: Hz	Range: 50 to 2000 Default: 2000
161	Get/Set	Zero Clamp Level	UIINT	Sets the zero clamp level. Unit: min^{-1}	Range: 0 to 10000 Default: 10
162	Get/Set	Rotation Detection Level	UIINT	Sets the rotation detection level. Unit: min^{-1}	Range: 0 to 10000 Default: 20
163	Get/Set	Speed Coincidence Signal width	UIINT	Sets the speed coincidence signal output width. Unit: min^{-1}	Range: 0 to 100 Default: 10
165	Get/Set	Overflow Level	UIINT	Sets the overflow level. Unit: 0.256 mm	Range: 1 to 32767 Default: 1024
166	Get/Set	Brake Reference Servo Off Delay Time	UIINT	Sets the brake reference servo off delay time. Unit: 10 ms	Range: 0 to 50 Default: 0
167	Get/Set	Brake Reference Output Speed Level	UIINT	Sets the brake reference output speed level. Unit: min^{-1}	Range: 0 to 10000 Default: 100
168	Get/Set	Wait time For Brake	UIINT	Sets the waiting time for brake reference output during motor operation. Unit: 10 ms	Range: 10 to 100 Default: 50
169	Get/Set	Hold Time	UIINT	Sets the momentary hold time. Unit: ms	Range: 20 to 1000 Default: 20
170	Get/Set	Input Signal 1	UIINT	Sets the input signal selection 1.	Default: 2100
171	Get/Set	Input Signal 2	UIINT	Sets the input signal selection 2.	Default: 6543
172	Get/Set	Input Signal 3	UIINT	Sets the input signal selection 3.	Default: 8888
173	Get/Set	Input Signal 4	UIINT	Sets the input signal selection 4.	Default: 8888
174	Get/Set	Output Signal 1	UIINT	Sets the output signal selection 1.	Default: 3211
175	Get/Set	Output Signal 2	UIINT	Sets the output signal selection 2.	Default: 0000
176	Get/Set	Output Signal 3	UIINT	Sets the output signal selection 3.	Default: 0000
177	Get/Set	Fixed Parameter	UIINT	---	Default: 8888
178	Get/Set	Output signal Reversal Setting	UIINT	Sets output signal reversal settings.	Default: 0000
190	Get/Set	Regenerative Register Capacity	UIINT	Sets the regenerative register capacity. Unit: 10 W	Default: 0
191	Get/Set	Fixed Parameter	UIINT	---	Default: 0

Services

Service Code	Name	Description
0x0E	Get_Attribute_Single	Returns the specified attribute.
0x10	Set_Attribute_Single	Sets the specified attribute.

B

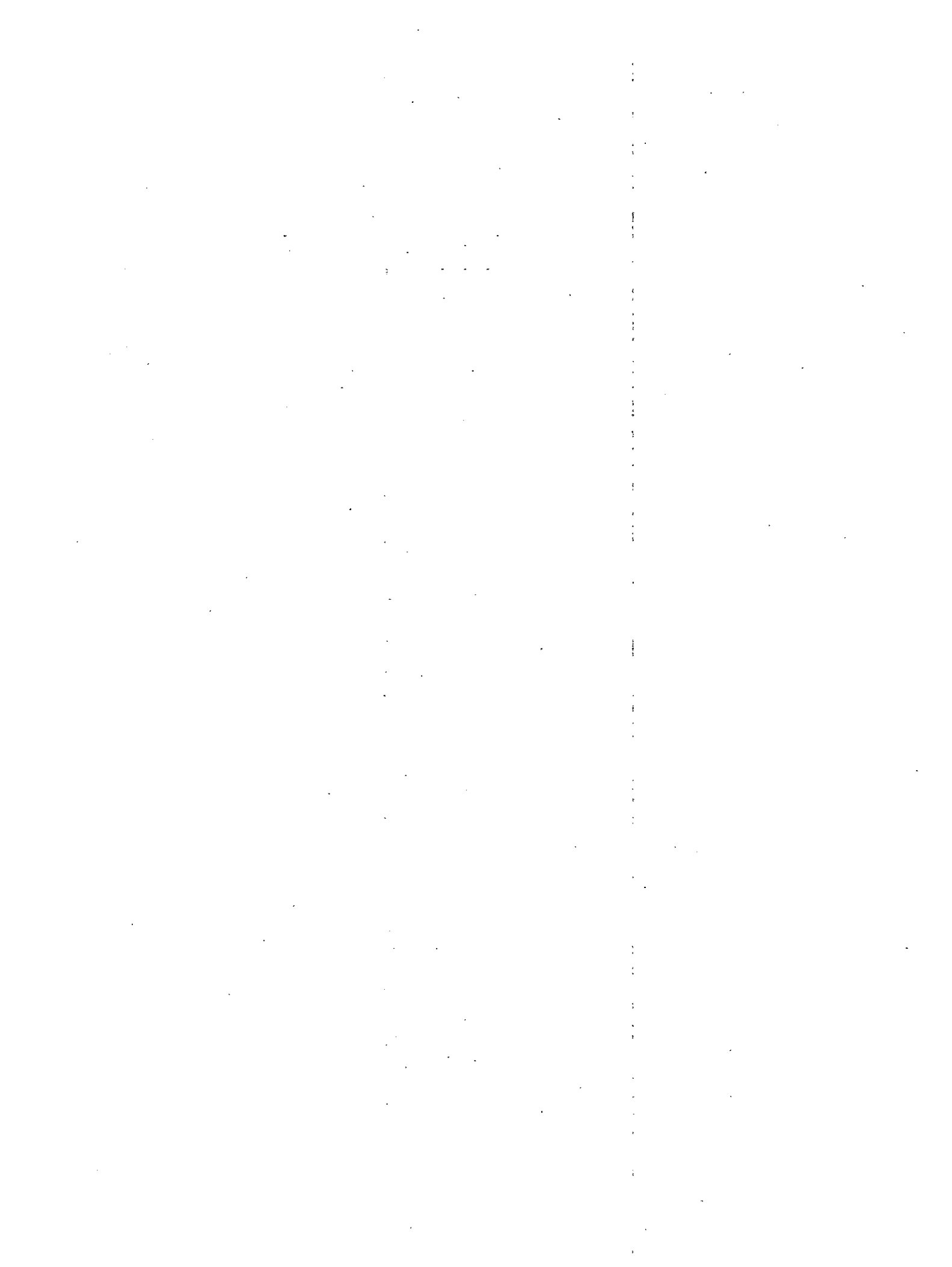

C

Alarm and Warning Codes

This appendix lists the alarm and warning codes within DeviceNet.



C.1 Alarm Codes C - 2

C.1 Alarm Codes

Alarm Codes that can be reported using DeviceNet Response Assembly 0x1E are as follows. The table describes indicator behavior and ALM signal output. These alarm codes are also displayed on SGDH Panel Operator.

MS indicator is the module status; NS indicator is the network status. The required indicator response is the following.

MS indicator flashes red on a recoverable error and it is solid red on a non-recoverable error. NS indicator follows the ODVA specification for indicator response.

Table C.1. Alarm Codes

Code	MS	NS	Alarm Description	SGDH	Description
0x01	Flashes Red.	---	Power Element Error	A03	Main Circuit Encoder Error
				A74	Overload of Surge Current Limit Resistor
0x02	Flashes Red.	---	Amplifier Overheat	A7A	Heat Sink Overheated
0x03	Flashes Red.	---	External Overheat	---	---
0x05	Flashes Red.	---	Over Voltage	A40	Overvoltage
				A41	Undervoltage
0x07	Flashes Red.	---	Control Power Error	A97	Control Power OFF
0x08	Lit Red.	---	Sensor Error	A81	Absolute Encoder backup Error
				A82	Encoder Checksum Error
				A83	Absolute Encoder Battery Error
				A84	Absolute Encoder Data Error
				A85	Absolute Encoder Overspeed
				A86	Encoder Overheated
				AC8	Absolute Encoder Clear Error
				AC9	Encoder Communication Error
				ACA	Encoder Parameter Error
				ACB	Encoder Echoback Error
ACC	Multi-turn limit mismatch				

Code	MS	NS	Alarm Description	SGDH	Description
0x0a	Flashes Red.	---	Over Load	A71	Overload: High Load
				A72	Overload: Low Load
				A73	Dynamic Brake Overload
				A91	Overload (warning)
0x0b	Flashes Red.	---	Over Speed	A51	Overspeed
0x0c	Flashes Red.	---	Speed Control Error	---	---
0x0d	Flashes Red.	---	Deviation Excess	AD0	Position Error Pulse Overflow
0x10	Flashes Red.	---	Main Power Error	A98	Main Power OFF
				AF1	Power Line Open Phase
0x12	Flashes Red.	---	Regeneration Error	A30	Regeneration Error
				A32	Regenerative Overload
				A92	Regenerative Overload (warning)
0x13	Lit Red.	---	Servo Processor Error	ABF	System Alarm
				AC1	Servo Overrun Detected
				AEA	SGDH System Error
				AED	Option System Error
0x14	Lit Red.	---	EEPROM Error	A02	Parameter Breakdown
				AEE	Parameter breakdown
0x15	Lit Red.	---	Memory Error	---	---
0x18	Flashes Red.	---	Over Current	A10	Over Current or Heat Sink Overheated
0x20	---	Lit Red.	Duplicate MAC ID	AE6	DeviceNet Duplicate MAC ID Error
0x21	---	Lit Red.	BUS-OFF Error	AE9	DeviceNet BUS-OFF Error
0x22	Lit Red.	---	Dual Port RAM Error	AE0	No NS310 Unit
				AE1	NS310 Unit Timeout
				AE2	Watchdog Counter Error of NS310 Unit
				AE7	No NS310 Unit Detected
				AEB	SERVOPACK Initial Access Error
				AEC	Watchdog Counter Error of NS310 Unit
0x23	Lit Red.	---	Wrap Around Error	---	---

Alarm and Warning Codes

Code	MS	NS	Alarm Description	SGDH	Description
0x24	Flashes Red.	---	Homing Error	---	---
---	---	---	---	---	---
0xF0	Flashes Red.	---	Parameter Setting Error	A04	Parameter Setting Error
				A94	Parameter Setting Error
0xF1	Flashes Red.	---	Command Error	A95	Command Error
0xF2	Flashes Red.	---	Combination Error	A05	Combination Error
0xF3	Flashes Red.	---	External Input Error	AB1	Reference Speed Input Read Error
				AB2	Reference Torque Input Read Error
0xF4	Flashes Red.	---	Switch Setting Error	AE8	DeviceNet Rotary Switch Error
---	---	---	---	---	---

Σ-II SERIES SGDH DeviceNet INTERFACE UNIT USER'S MANUAL

TOKYO OFFICE

New Pier Takeshiba South Tower, 1-16-1, Kaigan, Minatoku, Tokyo 105-6891 Japan
Phone 81-3-5402-4511 Fax 81-3-5402-4580

YASKAWA ELECTRIC AMERICA, INC.

2121 Norman Drive South, Waukegan, IL 60085, U.S.A.
Phone 1-847-887-7000 Fax 1-847-887-7370

MOTOMAN INC. HEADQUARTERS

805 Liberty Lane West Carrollton, OH 45449, U.S.A.
Phone 1-937-847-6200 Fax 1-937-847-6277

YASKAWA ELÉTRICO DO BRASIL COMÉRCIO LTDA.

Avenida Fagundes Filho, 620 Bairro Saude-Sao Paulo-SP, Brazil CEP: 04304-000
Phone 55-11-5071-2552 Fax 55-11-5581-8795

YASKAWA ELECTRIC EUROPE GmbH

Am Kronberger Hang 2, 65824 Schwalbach, Germany
Phone 49-6196-569-300 Fax 49-6196-888-301

Motoman Robotics Europe AB

Box 504 S38525 Torsås, Sweden
Phone 46-486-48800 Fax 46-486-41410

Motoman Robotec GmbH

Kammerfeldstraße 1, 85391 Allershausen, Germany
Phone 49-8166-900 Fax 49-8166-9039

YASKAWA ELECTRIC UK LTD.

1 Hunt Hill Orchardton Woods Cumbemauld, G68 9LF, United Kingdom
Phone 44-1236-735000 Fax 44-1236-458182

YASKAWA ELECTRIC KOREA CORPORATION

Kipa Bldg #1201, 35-4 Youido-dong, Yeongdeungpo-Ku, Seoul 150-010, Korea
Phone 82-2-784-7844 Fax 82-2-784-8495

YASKAWA ELECTRIC (SINGAPORE) PTE. LTD.

151 Lorong Chuan, #04-01, New Tech Park Singapore 556741, Singapore
Phone 65-282-3003 Fax 65-289-3003

YASKAWA ELECTRIC (SHANGHAI) CO., LTD.

4F No.18 Aona Road, Waigaoqiao Free Trade Zone, Pudong New Area, Shanghai 200131, China
Phone 86-21-5866-3470 Fax 86-21-5866-3869

YATEC ENGINEERING CORPORATION

Shen Hsiang Tang Sung Chiang Building 10F 146 Sung Chiang Road, Taipei, Taiwan
Phone 886-2-2563-0010 Fax 886-2-2567-4677

YASKAWA ELECTRIC (HK) COMPANY LIMITED

Rm. 2909-10, Hong Kong Plaza, 186-191 Connaught Road West, Hong Kong
Phone 852-2803-2385 Fax 852-2547-5773

BEIJING OFFICE

Room No. 301 Office Building of Beijing International Club, 21
Jianguomenwai Avenue, Beijing 100020, China
Phone 86-10-6532-1850 Fax 86-10-6532-1851

TAIPEI OFFICE

Shen Hsiang Tang Sung Chiang Building 10F 146 Sung Chiang Road, Taipei, Taiwan
Phone 886-2-2563-0010 Fax 886-2-2567-4677

SHANGHAI YASKAWA-TONGJI M & E CO., LTD.

27 Hui He Road Shanghai China 200437
Phone 86-21-6531-4242 Fax 86-21-6553-6060

BEIJING YASKAWA BEIKE AUTOMATION ENGINEERING CO., LTD.

30 Xue Yuan Road, Haidian, Beijing P.R. China Post Code: 100083
Phone 86-10-6233-2782 Fax 86-10-6232-1536

SHOUGANG MOTOMAN ROBOT CO., LTD.

7, Yongchang-North Street, Beijing Economic Technological Investment & Development Area,
Beijing 100076, P.R. China
Phone 86-10-6788-0551 Fax 86-10-6788-2878



YASKAWA ELECTRIC CORPORATION